



TELEDYNE INSTRUMENTS

Monitor Labs

A Teledyne Technologies Company

sensor^e

Chemiluminescence NO/NO₂/NO_x Analyzer (TML41)

0-50 ppb to 0-20 ppm ranges, user selectable

Independent ranges for NO, NO₂, NO_x

Microprocessor controlled for versatility

Multi-tasking software allows viewing of test variables while operating

Continuous self checking with warning alarms

Permeation drier on ozone generator

Ethernet and RS232 ports for remote operation

Digital status outputs provide instrument condition

Adaptive signal filtering optimizes response time

Temperature & pressure compensation

Converter efficiency correction software

Continuous automatic zero correction

Catalytic ozone scrubber

Internal zero and span check (optional)

Internal data logging with 1 minute to 24 hour multiple averages (over 500,000 records)



The sensor-e[®] NO_x uses the proven chemiluminescence detection principle, coupled with state-of-the-art microprocessor technology to provide the sensitivity, stability and ease of use needed for ambient or CEM monitoring requirements.

The analyzer uses multi-tasking software which allows complete control of all functions while providing online indication of important operating parameters. Measurements are automatically compensated for temperature and pressure changes.

In addition, stability is enhanced by an Auto-Zero circuit that continuously provides a true zero reference. The result is sensitive, accurate, and dependable performance under the harshest operating conditions.

All sensor-e[®] instruments include built in data acquisition capability using the analyzer's internal memory. This allows the logging of multiple parameters (over 500,000 records) including averaged or instantaneous concentration values, calibration data and operating parameters such as pressures and temperatures.

Stored data are easily retrieved through the Ethernet port via sensor-e.com software or from the front panel, allowing the operator to perform predictive diagnostics and enhanced data analysis by tracking parameter trends.

The sensor-e[®] NO_x combines lighter weight, rugged construction, ease of use, powerful diagnostics, modular design and outstanding performance to yield the ideal tool for today's gas monitoring requirements.



TELEDYNE INSTRUMENTS
 Monitor Labs
 A Teledyne Technologies Company

sensor^e[®]

Chemiluminescence NO/NO₂/NO_x Analyzer (TML41)

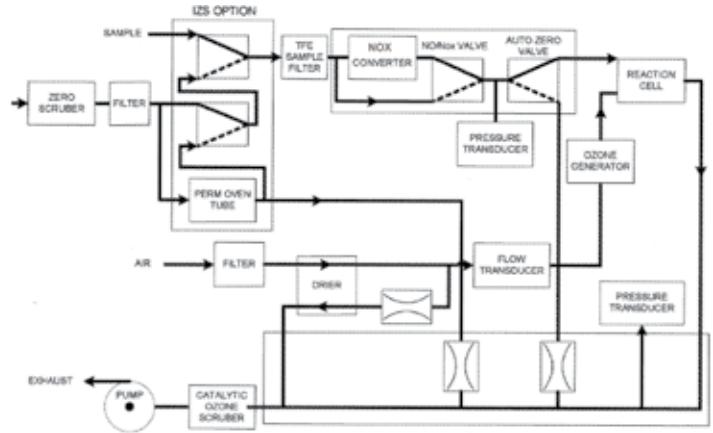

SPECIFICATIONS

Model:	TML-41
Ranges:	0-50ppb to 0-20,000 ppb full scale, user selectable; independent NO, NO ₂ , NO _x ranges and autoranging supported.
Units:	ppb, ppm, ug/m ³ , mg/m ³
Zero Noise:	<0.2 ppb (RMS)
Span Noise:	<0.5% of reading (RMS) above 50 ppb
Lower Detectable Limit (LDL):	0.4 ppb
Zero Drift:	<0.5ppb/24 hours, <1ppb/7 days
Span Drift:	<5% of reading/24 hours, <1% of reading/7 days
Lag Time:	20 seconds
Rise and Fall Time:	<60 seconds to 95%
Linearity:	1% of full scale
Precision:	0.5% of reading
Sample Flow Rate:	500 cm ³ / min ± 10%
Operating Temperature Range:	5-40°C (with EPA Equivalency)

Dimensions: (HxWxD):	7" (178 mm) x 17" (432mm) x 23.5" (597 mm)
Weight:	Analyzer 40 lbs (18 kg), External Pump 1.5 lbs (7kg)
Power:	100V, 220V-240V, 50/60Hz
Analog Outputs:	Bipolar, 10V, 5V, 1V, 0, 1V, selectable ± 10%
Recorder Offset:	±10%
Serial Port 1:	RS-232, DB-9M/RS485 optional
Serial Port 2:	Ethernet
Status (Digital):	8 outputs, 6 inputs (opto-isolated)
Current Output:	Specify up to three channels
Approvals:	Contact factory for current listing

NOTE: The values expressed above are in accordance with EPA definitions. All error specifications are based on constant conditions. Specifications exceed US EPA and Eignungsgeprüft requirements.

sensor^e[®] Chemiluminescence NO, NO₂, NO_x Analyzers includes:

- * External pump
- * Permeation air dryer for ozone generator air supply
- * Independent NO, NO₂, NO_x ranges
- * Auto Ranging
- * 5 micron filter
- * 8 digital status outputs, 6 inputs
- * Multi-drop RS-232 connection
- * Ethernet port
- * Sensor-e.com remote control software

Specify output DC voltage:
 10V 5V 1V 0.1V

- Optional Equipment:**
- Rack mount brackets (19") with chassis slides
 - Rack mount brackets only
 - Isolated 0-20 mA or 4-20 mA output (specify up to three channels)
 - Paramagnetic 0-25% O₂ sensor
 - NDIR 0-20% CO₂

Accessories:

- RS-232 Cable
- Expendables Kit
- Spare Parts Kit
- Carrying handle

Specify input AC voltage & frequency:

- 100V - 115V 50Hz
- 220V - 240V 60Hz



35 Inverness Drive East Englewood, CO 80112
 Phone:303-792-3300 Fax: 303-799-4853
 tml_sales@teledyne.com www.teledyne-ml.com

Teledyne Monitor Labs, Inc. reserves the right to make changes in construction, design, specifications and/or prices without prior notice.