

ULTRAFLOW 150
GAS FLOW AND TEMPERATURE MONITOR
OPERATIONS MANUAL



SERIAL NUMBER: _____

DOCUMENT NO.: 1900-0100-01 REV. E

JANUARY 2014

Proprietary Information. All rights reserved by Teledyne Monitor Labs. No part of this book may be reproduced or copied in any form or by any means—graphic, electronic, or mechanical, including photocopying, taping, or information storage and retrieval systems—without written permission of the publisher.

Made in the United States of America

TABLE OF CONTENTS

	PAGE
1.0 SAFETY	1-1
1.1 Internationally Recognized Symbols Used on Teledyne Monitor Labs Equipment.....	1-1
2.0 SYSTEM OVERVIEW	2-1
2.1 System Description, Standard Equipment.....	2-1
2.1.1 Transducer Interface Enclosure (TIE).....	2-1
2.1.2 Purge Nozzle Assemblies	2-1
2.1.3 Protective Purge System.....	2-3
2.1.4 Enhanced Remote Panel	2-3
2.2 Specifications (Standard System)	2-5
3.0 OPTIONAL EQUIPMENT	3-1
3.1 Protective Purge Air System, (Dual).....	3-1
3.2 Local User Interface Key Pad and Display	3-1
3.3 Dual Analog Input Board	3-2
3.3.1 Barometric Pressure Sensor Assembly	3-2
3.3.2 External Temperature Measurement	3-3
3.4 Link Rod.....	3-4
3.5 6PT I/O PC Board option for 150DI	3-5
4.0 THEORY OF OPERATION	4-1
4.1 Physics of Measurement	4-1
4.1.1 Time of Flight Theory	4-1
4.1.2 Flow Volume Measurement	4-3
4.1.3 Wet Basis and Dry Basis Measurements.....	4-3
4.1.4 Correction to Standard Temperature and Pressure.....	4-3
4.2 Monitor Specific Theory	4-4
4.2.1 Box Car Integration	4-4
4.2.2 Operational Modes of the Transducer Interface Enclosure	4-4
5.0 TRANSDUCER INTERFACE ENCLOSURE (TIE).....	5-1
5.1 Mechanical Description	5-1
5.2 Electrical Description	5-2
5.2.1 External Interface PC Board	5-2
5.2.2 Power Supply Board	5-2
5.2.3 Flow Mother Board.....	5-2
5.2.4 Preamp Boards	5-8
5.2.5 (Optional) Dual Analog Input Board.....	5-9
5.2.6 (Optional) Local User Interface Key Pad and Display Assembly	5-9
5.2.7 Individual Button Function (When Pressed by Themselves)	5-12
5.2.8 Combinations of Buttons	5-13
5.2.9 6PT I/O PC Board option for 150DI	5-13
6.0 ENHANCED REMOTE PANEL W / MULTI I/O MODULE	6-1
6.1 Overview	6-1
6.2 Mechanical Description	6-1
6.3 Electrical Description	6-2
6.3.1 Input Power Requirement	6-2
6.3.2 Circuit Description (Overview).....	6-2
6.4 Operational Description--Menu Structure and User Interface	6-9
6.4.1 Memory Test	6-9

TABLE OF CONTENTS

(Continued)

	PAGE
6.4.2 Main Display Screen	6-10
6.4.3 Main Menu Screen	6-11
6.4.4 Service Data Menu.....	6-12
6.4.5 Status Code Help	6-12
6.4.6 Output Cal Tests	6-13
6.4.7 Output Module Configuration Menu	6-16
6.4.8 Display Properties Menu	6-18
6.4.9 Software Versions	6-19
6.4.10 System Properties Menu.....	6-19
6.4.11 View Trending Data.....	6-22
6.4.12 View Numerical Data.....	6-23
6.4.13 View Status History	6-23
6.4.14 View Alarms History	6-23
6.5 Multi I/O Software	6-24
6.5.1 Analog Outputs	6-24
6.5.2 Digital Inputs	6-24
6.5.3 Digital Outputs.....	6-25
7.0 INSTALLATION	7-1
7.1 Pre-Installation Planning and Preparation.....	7-1
7.2 Site Selection.....	7-1
7.2.1 Representative Sampling Location	7-2
7.2.2 Access to Sampling Location	7-2
7.2.3 Environmental Conditions at the Sampling Location	7-2
7.3 Equipment Mounting Considerations	7-2
7.3.1 Flange and Mounting Tube Installation.....	7-2
7.3.2 Purge System, Reference PURGE ASS'Y MTG., PLUMBING & CLEARANCE REQUIREMENTS Drawing	7-3
7.3.3 Purge Nozzle and Mounting Flange Assembly, Reference PURGE NOZZLE AND MTG. PLATE INSTALLATION-150 Drawing	7-4
7.3.4 Transducer Interface Enclosure Assembly, Reference XDUCER INTERFACE ENCLOSURE INSTALLATION Drawing	7-5
7.3.5 Junction Box, Reference JUNCTION BOX MTG. METHODS AND CLEARANCES Drawing.....	7-5
7.3.6 Enhanced Remote Panel Assembly, Reference ENHANCED REMOTE PANEL ASSEMBLY Drawing	7-5
8.0 SYSTEM CALIBRATION AND ADJUSTMENT	8-1
8.1 Transducer Interface Enclosure Calibration	8-1
8.1.1 Transducer Interface Enclosure Program Variables	8-1
8.2 Transducer Interface Enclosure Electronics Adjustment	8-8
8.2.1 Flow Mother Board.....	8-8
8.2.2 Preamp Board Adjustment.....	8-8
8.3 Remote Panel Calibration.....	8-8
8.3.1 Remote Program Variables.....	8-8
8.3.2 Enhanced Remote Panel Analog Adjustments	8-8
9.0 MAINTENANCE	9-1
9.1 Maintenance Schedule	9-1
9.1.1 After Initial Installation.....	9-1
9.1.2 Normal Maintenance.....	9-1

TABLE OF CONTENTS (Continued)

		PAGE	
9.2 Troubleshooting Guide		9-2	
APPENDIX A	Site Specification Data Sheets		
APPENDIX B	Maintenance Check Sheets		
APPENDIX C	Spare Parts		
	1900-0090-01 Ultraflow 150 Spare Parts Location Drawing		
APPENDIX D	Drawings		
<u>Drawing No.</u>	<u>Sheet</u>	<u>Rev</u>	<u>Description</u>
1900-0001-01	1 of 2	D	Ultraflow 150 Flange Installation (English)
1900-0001-02	2 of 2	D	Ultraflow 150 Flange Installation (Metric)
1900-0002-01	1 of 5	H	Ultraflow 150 System Installation, Dual Blowers
1900-0002-02	2 of 5	H	Ultraflow 150 System Installation, Single Blower
1900-0002-03	3 of 5	H	Ultraflow 150 System Installation, Small Stacks
1900-0002-04	4 of 5	H	Ultraflow 150 System Installation, X-Pattern
1900-0004	1 of 12	F	Ultraflow 150 50Khz Wiring Diagram (115/230 VAC)
1900-0004	2 of 12	F	Ultraflow 150DI 50Khz Direct Interface Wiring Diagram (115/230 VAC)
1900-0004	3 of 12	F	Ultraflow 150 X-Pattern 50Khz Wiring Diagram (115/230 VAC)
1900-0004	4 of 12	F	Ultraflow 150 X-Pattern Wiring Diagram (115/230 VAC)
1900-0004	5 of 12	F	Ultraflow 150DI X-Pattern Direct Interface Wiring Diagram (115/230 VAC)
1900-0004	6 of 12	F	Ultraflow 150 Long Range (14/20Khz) Wiring Diagram (115/230 VAC)
1900-0004	7 of 12	F	Ultraflow 150DI Long Range (14/20Khz) Direct Interface Wiring Diagram (115/230 VAC)
1900-0004	8 of 12	F	Ultraflow 150 Long Range (20/14Khz) X-Pattern Wiring Diagram (115/230 VAC)
1900-0004	9 of 12	F	Ultraflow 150 Long Range (20/14Khz) X-Pattern Wiring Diagram (115/230 VAC)
1900-0004	10 of 12	F	Ultraflow 150DI Long Range (14/20Khz) X-Pattern Direct Interface Wiring Diagram (115/230 VAC)
1900-0004	11 of 12	F	Ultraflow 150 50Khz Std. Wiring Diagram (No J-Boxes) – 115/230V
1900-0004	12 of 12	F	Ultraflow 150DI 50Khz Direct Interface Wiring Diagram (No J-Boxes) – 115/230V
1900-0006-01	1 of 1	B	Ultraflow 150 Flange Installation X-Pattern
1901-0008-01	1 of 5	B	Purge Nozzle and Mtg. Plate Installation-150, Standard Range, 50Khz
1901-0008-02	2 of 5	B	Purge Nozzle and Mtg. Plate Installation-150, Long Range LR003, 20Khz
1901-0008-04	4 of 5	B	Purge Nozzle and Mtg. Plate Installation-150, Extended Long Range LR006, 14Khz

TABLE OF CONTENTS (Continued)

<u>Drawing No.</u>	<u>Sheet</u>	<u>Rev</u>	<u>Description</u>
1901-0008-05	5 of 5	B	Purge Nozzle and Mtg. Plate Installation-150, Extended Long Range LR007, 14Khz w/Horn
1903-0000	3 of 4	M	Transducer Interface Enclosure Std. Wiring Diagram
1903-0000	4 of 4	M	Transducer Interface Enclosure Direct Interface Wiring Diagram
1903-0010-01	1 of 1	B	Transducer Interface Enclosure Installation
1903-0011-02	2 of 2	C	Transducer Interface Enclosure Internal Layout
1004-0008-01	1 of 2	J	Purge System Assy, Dual 42CFM Blowers
1904-0000-01	1 of 2	A	Purge System Assy, Single 110CFM Blower
1904-0000-02	2 of 2	A	Purge System Assy, Single 42CFM Blower
1906-0010-01	1 of 2	A	Junction Box Mtg. Methods and Clearances, 20/14Khz
1906-0010-02	2 of 2	A	Junction Box Mtg. Methods and Clearances, 50Khz
1803-2003-02	2 of 2	H	Enhanced Remote Panel Customer Drawing
1903-0012-02	2 of 2	B	UF150 Subpanel Assy, Upgrade Installation
1900-0005	1 of 4	C	Upgrade Ultraflow 100 to 150 50Khz Wiring, W/New TIE Subpanel in Existing Stack Elect. Box
1900-0005	2 of 4	C	Upgrade Ultraflow 100 to 150 20/14Khz Wiring, w/New TIE Subpanel and Buffer Boards in Existing J-Boxes

APPENDIX E Enhanced Serial Port Communication Protocol

1.0 SAFETY

1.1 INTERNATIONALLY RECOGNIZED SYMBOLS USED ON TELEDYNE MONITOR LABS EQUIPMENT

This equipment is intended only for the purposes specified in this manual. Safety protections inherent in this equipment may be impaired if the Ultraflow 150 is used in a manner different than specified herein.

The following are internationally recognized symbols used on the Ultraflow 150 along with specific cautions applicable to the equipment.



Label Standard Number:

ISO 3864 B.3.1

Generic meaning:

CAUTION: RISK OF DANGER. CONSULT MANUFACTURER'S DOCUMENTATION.

Cautions Invoked By This Label for the Ultraflow 150:

1. The Transducer Interface Enclosure (TIE) and Enhanced Remote Panel (ERP) power supplies are fused on both grounded (neutral) and ungrounded (high line) mains supply conductors.
2. The Transducer Interface Enclosure (TIE) and Junction Box Covers are to be opened only by trained service personnel.
3. This equipment must be installed by a qualified electrician as per applicable local electrical codes.
4. The Protective Purge System blowers (both Single and Dual) are permanently connected devices whose overcurrent protection and supply disconnection must be provided externally and installed by a qualified electrician in accordance with applicable local electrical codes. Consult the Ultraflow 150 Wiring Diagrams in Appendix D of this manual for further guidance of appropriate overcurrent and supply disconnection requirements.
5. The Transducer Interface Enclosure, Junction Boxes and Protective Purge System enclosure protection ratings apply only if "liquid tight" conduit and fittings (such as Appleton Electric type ST, STB or STN or equivalents) are installed by qualified electricians as per the fitting manufacturer's documentation.



Label Standard Number:

ISO 3864 B.3.6

Meaning:

CAUTION: RISK OF ELECTRIC SHOCK.

Hazardous AC supply inside. Remove power before servicing.



Label Standard Number:

ISO 3864, DIN 4844-2 D-W026

Meaning:

CAUTION: HOT SURFACE. DO NOT TOUCH.

This caution refers only to the single blower style of Protective Purge System.

2.0 SYSTEM OVERVIEW

This manual describes the installation, operation, calibration and routine maintenance of the Teledyne Monitor Labs Ultraflow 150 Ultrasonic Stack Flow Measurement System.

2.1 SYSTEM DESCRIPTION, STANDARD EQUIPMENT

The Ultraflow 150 system consists of the following standard equipment.

Transducer Interface Enclosure (TIE)

Purge Nozzle Assemblies

Protective Purge Air System (Single)

Enhanced Remote Panel (ERP)
(Not supplied with a 560DI, see section 3.5)

As shown on the Ultraflow 150 Installation Drawings, the first three above are located on the stack. The Enhanced Remote Panel Assembly is typically located in the plant Control Room or CEMS Shelter.

2.1.1 Transducer Interface Enclosure (TIE)

The Transducer Interface Enclosure Assembly contains sophisticated sampling electronics that control the transmit and receive signals from the transducers and calculates the flow velocity, flow volume and temperature. It also provides power for the purge fail sensors. These measurement data are transmitted to the Enhanced Remote Panel via a commercial network communication protocol.

Each TIE is capable of controlling and performing analysis of up to two pairs of Purge Nozzle Assemblies.

2.1.2 Purge Nozzle Assemblies

There are two Purge Nozzle Assemblies located on opposite sides of the stack or duct. Each houses an ultrasonic transducer and is designed to conduct the protective purge air around the transducer to prevent contamination from the effluent gas stream. The Purge Nozzles are constructed using Teflon, stainless steel, and other corrosion resistant materials to provide a long service life. The actual transducer element is housed in the Transducer Housing Subassembly and is located near the end of the Purge Nozzle Nosepiece.

The stack geometry, wall thickness, and mounting details determine the length of the Purge Nozzle Assemblies.

Mounting of the assembly is accomplished using four 1/2-13 threaded rods and nuts to hold the flange seal and squeeze ring in place. A quick disconnect latching mechanism secures the assembly to the threaded rods.

Electrical connections include those from the Transducer Housing Subassembly BNC connector and from the purge sensor switch. Both the transducer coax cable and the purge air sensor cable are housed in a single length of 3/4" flexible conduit connected from the rear of the Purge Nozzle Assembly to the junction box.

2.1.2.1 Transducer Assemblies

The wide variety of user stack geometry, effluent composition and effluent temperatures require that several different types of ultrasonic transducers be employed to meet individual user requirements. Decisions on which transducer type is appropriate for your particular application are made by the Teledyne Monitor Labs factory based on information supplied by the user prior to factory configuration and checkout. Documentation of the transducer type for your particular monitor is included as part of Appendix A of this manual.

2.1.2.1.1 Electrostatic Transducer

The Electrostatic Transducer is used in the majority of all Ultraflow 150 applications. It is typically employed in instrument pathlengths less than 26 feet (8 meters). Its electrostatic characteristics maximize sampling accuracy at short to moderate pathlengths and in low to moderate acoustic attenuation conditions.

Consult the Site Specification Data sheet of Appendix A for information on the transducer type of your individual monitor.

2.1.2.1.2 Long Range Transducer (LR003)

The LR003 Transducer is employed where the instrument pathlengths are about 30 to 50 feet (9-15 meters). Additional sample medium characteristics may present acoustic attenuation conditions that reduce the ultrasonic signal strength of the Standard Transducer below acceptable levels. This may require the use of the LR003 at some pathlengths less than 30 feet (9 meters). Long Range Transducers are capable of higher drive (transmit) energies and have horn designs unique to their operating frequencies.

Consult the Site Specification Data sheet of Appendix A for information on the transducer type of your individual monitor.

2.1.2.1.3 Extended Long Range Transducers (LR004 through LR007)

As pathlength, temperature, velocities and medium molecular weight increase, the acoustic attenuation increases vigorously. As these factors combine to challenge the signal strength of the Long Range Transducer LR003, the Extended Long Range Transducers are used to obtain satisfactory operation in these conditions. This family of transducers (LR004 through LR007) uses a common transducer element design with various purging and horn designs. These designs ensure accurate measurement signals throughout the operating range of the most challenging acoustic effluent conditions.

Consult the Site Specification Data sheet of Appendix A for information on the transducer type of your individual monitor.

2.1.3 Protective Purge System

The Standard Purge System for Electrostatic Transducers consists of a single blower that has a dual outlet and flow restriction device to provide clean, proportioned purge air to each of the two Purge Nozzle Assemblies. This configuration can be employed where the effluent pressures are negative to modestly positive. Use of the single Protective Purge Air may not be recommended in cases of high positive stack pressures. Long range uses a dual blower system.

The Purge System provides filtered air to keep the effluent from contacting the transducers. The air is injected into the stack through the nozzles of these assemblies by actually having air blow around and in front of the transducers. Each assembly has a purge air sensor switch that remains activated as long as the purge air is flowing. If purge air is lost to either transducer an indication is provided at the Enhanced Remote Panel.

2.1.4 Enhanced Remote Panel

2.1.4.1 Enhanced Remote Display

The Enhanced Remote Display is built with a modular design. It is 19" rack mountable. The software is menu driven and uses a commercial network communications platform. It uses a membrane switch keypad, a 4 ½" Liquid Crystal Display (LCD) with graphics capability and a key lockout for critical functions.



2.1.4.2 Multi I/O Board

The Multi I/O Board is installed in the Enhanced Remote Panel chassis and has eight relay outputs, eight digital inputs, and four individually

isolated analog outputs. The connections to the user interface devices from the Multi I/O Board are made via connectors on the back panel of the Enhanced Remote Display Panel.

2.1.4.3 Ethernet Module

The Ethernet Module is a single printed circuit board located inside of the ERP chassis. External connection to the Ethernet Module is made via a standard RJ45 connector socket in the rear panel of the ERP. The module will provide web browser-based remote access, configuration and control of the Ultraflow 150. At the same time the Ethernet Module can provide HTML web pages for user interface and fast Modbus TCP access to instrument data and parameters.

The details of this powerful ERP feature are described in its own instruction manual which is provided with the instrument. The customer supplied network cable may be installed into the socket marked “Ethernet” at the right hand side of the ERP rear panel.

This option can be supplied in a standalone version for users who purchased the 560DI.

3.0 OPTIONAL EQUIPMENT

The components listed below are optional on the Ultraflow 150 system. They are not included on a standard system. Please consult the Site Specification Data sheets in the back of this manual for the details of your particular system.

Protective Purge Air System, Dual

Local User Interface Key Pad and Display

Dual Analog Input Board

Link Rod

6PT I/O PC Board Option

3.1 PROTECTIVE PURGE AIR SYSTEM, (DUAL)

The Dual Protective Purge Air System consists of two blowers and weather covers designed to supply purge air to each Purge Nozzle assembly. This configuration uses separate purge blowers to provide clean purge air to each of the two Purge Nozzle Assemblies. This option can be employed where the effluent pressures are very positive and is used on all standard long range installations.

Consult the Site Specification Data sheet of Appendix A for information on the configuration of your individual monitor

3.2 LOCAL USER INTERFACE KEY PAD AND DISPLAY

The Local User Interface Key Pad and Display option provides an operator interface capability at the Transducer Interface Enclosure (TIE) on the stack. This is a Local User Interface that will provide the ability to evaluate the operation and setup variables of the system from the TIE location.

This assembly contains a 6 character, 7 segment display and a keypad. The two leftmost characters are GREEN while the 4 remaining characters to the right are RED. The display is organized so that the 2 GREEN characters indicate the software bank location of data, operational variables, markers or configuration modifiers. The 4 RED characters to the right hold the value of the data, status or marker in that bank location.

The locations are organized into different categories or BANKS of data and parameters. The leftmost GREEN letter character describes the

BANK or category of display information, while the second GREEN numeric character identifies the individual memory location within the BANK.

Consult the Site Specification Data sheet of Appendix A for information on the configuration of your individual monitor.

3.3 DUAL ANALOG INPUT BOARD

The Dual Analog Input Board option is required when the user wishes to have the Ultraflow 150 take in external information on stack pressure and temperature in order to convert the stack flow volume values to standard conditions.

3.3.1 Barometric Pressure Sensor Assembly

A Barometric Pressure Sensor Assembly is available for the purpose of correcting flow volume data to standard pressure. The assembly contains an on-board absolute pressure transducer that reads the ambient pressure outside the Transducer Interface Enclosure via a sealed vent line. This approach is recommended only for applications in which the static gage pressure of the process is not likely to undergo dramatic changes. For cases where static pressure varies widely, a pressure transducer measuring the actual process pressure will deliver maximum accuracy. See the System Properties Menu section (Section 6.0) of this manual for external pressure transducers.

The Barometric Pressure Sensor Assembly is inserted into a connector on the Dual Analog Input Board, a separate option located in the Transducer Interface Enclosure. The Dual Analog Input Board provides the required operating power for the assembly and converts the pressure transducer voltage to 12 bit digital data for use by the Flow Mother Board.

Consult the Enhanced Remote section (Section 6.0) of this manual for information on calibration of the Barometric Pressure Sensor Assembly.

See Table 3-1 below for the Dual Analog Input Board jumper settings for use of the Barometric Pressure Sensor Assembly.

Table 3-1
Dual Analog Input Board Jumpers for Pressure Input

DESCRIPTION	JUMPER NUMBER	LABEL	POSITION	WIRING
Barometric Pressure Assembly	JU2	Don't Care	Don't Care	None
	JU3	INT	1-2	
4-20mA Pressure Transmitter	JU2	CUR	1-2	J4 Terminals 1(+) and 2(-)
	JU3	EXT	3-4	
0-5VDC Pressure Transmitter	JU2	VOL	3-4	J4 Terminals 3(+) and 2(-)
	JU3	EXT	3-4	

3.3.2 External Temperature Measurement

The Ultraflow 150 can measure medium temperature in two manners:

INTERNAL MEDIUM TEMPERATURE: This measurement uses the speed of sound data derived from the time of flights between the upstream and downstream ultrasonic transducers. Since speed of sound is directly proportional to the square root of absolute temperature, a temperature measurement can be made based on this data provided the concentrations of the major constituent gases (usually O₂, CO₂, H₂O and N₂) are either relatively constant or change predictably as a function of speed of sound. Examples of applications where this is true include flow monitoring of single fuel utility boiler stack gas emissions, cement kiln combustion emissions, secondary combustion air and process steam boiler emissions.

EXTERNAL MEDIUM TEMPERATURE : This measurement utilizes external, non-ultrasonic sensors to establish medium temperature. This technique is recommended when the concentrations of the major constituent gases (usually O₂, CO₂, H₂O and N₂) change unpredictably or are not a function of speed of sound. In these cases, the absolute values of the Ultraflow 150's INTERNAL MEDIUM TEMPERATURE will be inaccurate by magnitudes roughly proportional to the change in molecular weight. An example of such an application is a multi-fuel (i.e., one that can run on coal or natural gas at base load) utility boiler.

The Dual Analog Input Board option is required to implement the EXTERNAL MEDIUM TEMPERATURE option. The Dual Analog Input Board is compatible with a variety of external temperature sensors: 1000 ohm 2 wire RTD's (see the next sub-section of this manual), 4 – 20 mA and 0 to 5 Volt. Thermocouples are not supported. See the System Properties Menu section (Section 6.0) of this manual for information on calibration of EXTERNAL MEDIUM TEMPERATURE devices.

3.3.2.1 Resistive Temperature Device (RTD)

An optional Resistive Temperature Device (RTD) probe is available for use as an EXTERNAL MEDIUM TEMPERATURE sensor. The heart of the assembly is a 1000 ohm 2 wire RTD. Consult the system wiring diagram for connection of the RTD Assembly to the TIE.

The optional Dual Analog Input Board is required to use the RTD assembly. See Table 3-2 for the applicable Dual Analog Input Board jumper settings for the assembly.

Table 3-2

Dual Analog Input Board Jumpers for External Temperature

JUMPER	OPTIONS	DEFAULT	FUNCTION
JU1	RTD = 1-2 CUR = 3-4 VOL = 5-6	RTD = 1-2	Selects external input to temperature channel between RTD, 1-5 volts, or 4-20 mA
JU4	3-4 (1000 ohms)	3-4 (1000 ohms)	Selects the 32°F (0°C) RTD resistor for calibration
JU7	3-4 (1000 ohms)	3-4 (1000 ohms)	Selects the 1000 ohm RTD for operations

3.4 LINK ROD

For stacks with an annulus or thick outer walls that must be bridged by the Ultraflow 150 Purge Nozzle Assemblies, Teledyne Monitor Labs offers the Link Rod option whenever the Purge Nozzle Assemblies would exceed 72 inches (183 cm) in length. Beyond this length, the standard assemblies become unwieldy and are difficult to align in the center of their ports. The Link Rod Assemblies replace the standard Purge Nozzles. The Link Rod Assemblies consist of a transducer housing with skids to center it in the port, and a series of short rods that connect or disconnect as the transducer housing is inserted or removed from the port. The Link Rod option also reduces the amount of removal clearance required to extract the transducers for maintenance and cleaning. This mounting option is complete with all hardware, flanges and seals.

Consult the Site Specification Data sheet of Appendix A for information on the configuration of your individual monitor.

3.5 6PT I/O PC BOARD OPTION FOR 150DI

The Six Point I/O Board is an optional device intended to provide a low cost Direct Interface feature to the Ultraflow 150DI where analog output and control signals are supplied directly from the Transducer Interface Enclosure (TIE) Assembly. The PC Board has 2 analog outputs, 2 digital inputs and 2 relay outputs. The Local User Interface Key Pad and Display option comes standard with the 6PT I/O option. The configuration of the 6PIO Board is software selectable using the PC to Modbus interface software supplied with the Ultraflow 150DI. Below are the specifications. The details on this option are described in its own instruction manual.

Six Point I/O Board Specifications

SIX POINT I/O BOARD ANALOG OUTPUTS

Number	2
Isolation Type	<i>Optical & capacitive barriers; channel to channel, channel to circuit common & earth</i>
Minimum Isolation Voltage	<i>500V_{peak}*, 500VDC*</i>
Output Type	<i>4-20mA with live 4mA zero, OR 0-20mA w/o live zero</i>
Maximum Load Resistance	<i>900 ohms</i>
Maximum Offset	<i>±0.05% of full scale</i>
Total Output Error	<i>±0.30% of full scale</i>

SIX POINT I/O BOARD DIGITAL INPUTS

Number	2
Modes	<i>Isolated and Non-isolated</i>
Isolated Mode Minimum Isolation Voltage	<i>500V_{rms}*</i>
Isolated Mode Minimum Actuation Voltage	<i>5VDC (user supplied)</i>
Isolated Mode Maximum Actuation Voltage	<i>24VDC (user supplied)</i>
Isolated Mode Maximum Input Current	<i>50mA @ 24VDC</i>
Non-Isolated Mode Actuation Condition	<i>Dry contact closure</i>
Non-Isolated Mode Internal Operating Voltage	<i>5VDC</i>

SIX POINT I/O BOARD RELAY OUTPUTS

Number	<i>2 SPST, N.O. (Single Pole Single Throw, Normally Open or Normally Closed [jumper selectable])</i>
Minimum Isolation	<i>500V_{rms}*</i>
Maximum Contact Voltage	<i>250VAC</i>
Maximum Contact Current	<i>1Amp AC, 1Amp DC</i>

*I/O wires with respect to earth (common mode).

4.0 THEORY OF OPERATION

4.1 PHYSICS OF MEASUREMENT

4.1.1 Time of Flight Theory

The Ultraflow 150 system measures the transit times of ultrasonic tone bursts through the gas stream to determine flow velocity, temperature, and volume.

Each effluent path monitored by the Transducer Interface Enclosure (TIE) uses two transducers placed on opposite sides of the stack or duct (see Ultraflow 150 System Installation Drawing, Appendix D). The transducers are pointed at each other with one transducer located diagonally upstream from the other. Each transducer acts alternately as a transmitter or receiver with the ultrasonic waves passing through the centroid of the stack or duct to the other transducer. This makes the measurements a line average of the tone burst path length. When a tone burst is sent through the gas stream from the upstream transducer to the downstream transducer the movement of the gas stream reduces the time required to traverse the distance. When the tone burst is traveling against the gas stream from the downstream to the upstream transducer, the traverse time is increased. When there is no gas flow, the time required for the ultrasonic tone bursts to traverse the gas stream in either direction is the same. Both the upstream and downstream transit times are measured by the Transducer Interface Enclosure to an accuracy of 0.5 microseconds.

Figure 4-1

Transit Time Theory

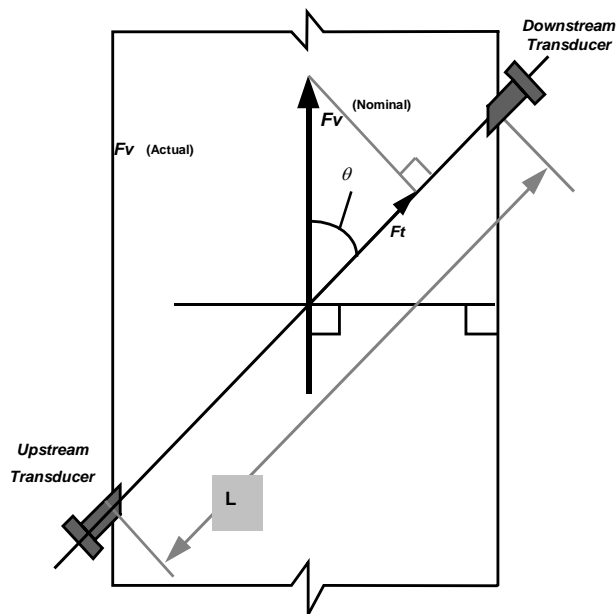

4.1.1.1 Flow Velocity Measurement

The root measurement of the Ultraflow 150 is transit time. The difference between upstream and downstream transit times through the gas stream is directly proportional to the velocity of the gas stream. From transit time and the following physical equations the TIE calculates flow velocity. This velocity measurement is inherently independent of the temperature, density, viscosity, and particulate concentration since these terms drop out of the simplified equations.

1)

Velocity of Sound from Upstream to Downstream Transducer

2)

Velocity of Sound From Downstream to Upstream Transducer

Where:

C_s = The Speed of Sound

F_v = Flue Gas Velocity

θ = Transducer Angle to Flow

V = Velocity of Respective Tone Bursts

3) Subtract equations 1 & 2:

and solving for F_v :

4)

substituting

5)

F_v is the Line Average Velocity.

And: t = Transit times of sound between the transducers

L = Distance between the transducers

4.1.1.2 Temperature Measurement

By knowing the precise time required for the tone bursts to traverse the gas stream the speed of sound is calculated. The influence on the speed of sound resulting from temperature change is well established. Therefore, the gas stream temperature measurement may be calculated directly from the speed of sound determination. This measurement will remain accurate so long as the gas composition is from a single fuel source or remains relatively consistent in terms of its molecular weight.

If multi-fuel operation is expected, the Ultraflow 150 should be configured using an external temperature device that may be facilitated using the optional Dual Analog Input Board.

Consult the Site Specification Data sheet of Appendix A for information on the configuration of your individual monitor

4.1.2 Flow Volume Measurement

Once the flow velocity (Fv) has been determined it is multiplied by the cross-sectional area of the stack or duct to determine the actual volumetric flow. The units may be English or Metric, per hour, minute or second, according to a software selection.

4.1.3 Wet Basis and Dry Basis Measurements

The Ultraflow 150 gives a wet basis reading only. A wet basis measurement is one that includes the water vapor component of the effluent in the measurement. A dry basis measurement is one that removes the water vapor and makes the measurement on the remaining components of the effluent.

4.1.4 Correction to Standard Temperature and Pressure

Effluent pressure and temperature can vary dramatically from one process to another. For the sake of uniform reporting most regulatory applications require the volume and mass flow to be reported in standard pressure and temperature units. To do this, the monitor's measurement must be corrected according to the ideal gas law for the agency specified pressure and temperature. US EPA standard (reference) conditions are 68⁰ F and 29.92 in. Hg for English units and 20⁰ C and 101.32 Kpa for metric units. The Ultraflow 150 has the ability to take inputs from an external pressure transducer and a temperature device. The monitor's internal temperature measurement may also be used for correction. Each correction factor can be turned on or off individually to accommodate systems that do these functions elsewhere.

To convert actual flow volume to standard flow volume:

$$\mathbf{Flow}_{Standard} = \mathbf{Flow}_{Actual} \times \left[\frac{\mathbf{P}_{Actual}}{\mathbf{P}_{Ref}} \times \frac{\mathbf{T}_{Ref}}{\mathbf{T}_{Actual}} \right]$$

NOTE: The temperature must be in absolute terms Eg. 459.69 + deg^f

4.2 MONITOR SPECIFIC THEORY

4.2.1 Box Car Integration

At the heart of the Ultraflow 150 is a signal conditioning technique known as “Boxcar Integration”. Each time a tone burst traverses the stack a 16 millisecond window of interest within the receive signal is digitized by an A/D converter in 0.5 microsecond intervals. This results in a window of interest composed of 32,768 digital values or “boxcars”. For each tone burst during the integration period the value of each boxcar is added to the sum of all previous boxcars having the same location in the window. For example on the fourth tone burst of the integration period, the value of boxcar #100 will be added to the sum of the three previous boxcar #100s. This technique greatly enhances the signal to noise ratio. The true receive signals occur at virtually the same time (boxcar) for each tone burst in the average period and are always positive thus add up faster than the background noise which is random in time.

At the end of the integration period the resulting window of 32,768 data bits is sent through the digital signal processing algorithms and the boxcar integrator reset for the next integration period. The signal processing algorithms determine the center of the receive signal and thus the exact transit time across the stack.

4.2.2 Operational Modes of the Transducer Interface Enclosure

4.2.2.1 NORMAL Mode

During the NORMAL mode the transducers of each transducer pair are alternately transmitting and receiving signal through the medium and performing the gas stream velocity calculations. The mode code for NORMAL mode is 1. During NORMAL mode the TIE cycles the transmit pulses to the transducers on a round robin basis so there are never any two transducers transmitting or receiving at the same time. If only one path (transducer pair) is being used, the upstream and downstream transducers will alternate. The TIE processes and reports the data at the end of each integration period.

4.2.2.2 ZERO Calibration

The mode code for ZERO mode is 4. During the ZERO mode the TIE processes the signals in a slightly different manner. When both a ZERO and SPAN calibration have been completed, a comprehensive full system evaluation check has been done. During ZERO, only the upstream transducer transmits and it transmits at twice the normal rate. The downstream transducer is receiving only. The TIE's electronics process each pair of signals as though they were typical upstream and downstream signals. Since all ZERO mode receive signals go through the gas stream in the same direction, the time required to traverse the gas stream should be essentially the same. With no difference in the transit times, the flow should indicate zero velocity. Small fluctuations in the upstream transmit and downstream receive properties will indicate non-zero flow readings.

4.2.2.3 SPAN HIGH Calibration Mode (Upscale Calibration)

The mode code for SPAN HIGH mode is 2. During SPAN HIGH only the downstream transducer transmits and it transmits at twice the normal rate. The upstream transducer is receiving only. The TIE's electronics process each pair of signals as though they were upstream and downstream signals. This would be expected to produce another zero flow indication. However, in the "SPAN HIGH" mode every other received tone burst is delayed by a predetermined amount. This means that the TIE sees a difference in the time required for the upstream and downstream tone bursts to traverse the gas stream. Small fluctuations in the downstream transmit and upstream receive properties or electronics shifts will show changes in the expected flow readings.

4.2.2.4 SPAN LOW Calibration Mode

The mode code for SPAN LOW mode is 3. During SPAN LOW mode the TIE controls the transducers and processes the signals in the same way as in the SPAN HIGH mode except that the calculated delay for every other receive signal is shorter. This gives a shorter transit time difference, thus a lower expected flow volume.

4.2.2.5 Acquire Modes

There are four Acquire Modes, *NORMAL Acquire = 5*, *SPAN HIGH Acquire = 6*, *SPAN LOW Acquire = 7*, and *ZERO Acquire = 8*. Acquire modes are invoked during transitions from one mode to another. When the TIE changes modes, the acquire for the requested mode will be indicated until the number of integration periods needed for a good average has been reached. For example if the number of integration periods per normal average is set to 4 and a mode change to ZERO mode initiated, the TIE will indicate ZERO Acquire mode for 4 integration periods before switching to ZERO mode for the balance of the calibration periods.

NOTE: *The number of periods for a calibration average must be equal to or larger than the number for a normal average.*

(This page intentionally left blank.)

5.0 TRANSDUCER INTERFACE ENCLOSURE (TIE)

The Transducer Interface Enclosure houses the electronics that control the stack-mounted portion of the Ultraflow 150. Each Ultraflow 150 TIE has the ability to monitor two separate paths on the same stack. The TIE will take a full set of measurements from each path as well as calculate average values of the two paths combined.

5.1 MECHANICAL DESCRIPTION

The Transducer Interface Electronics is enclosed in a stainless steel NEMA 4X type enclosure. All cable entries in the enclosure are located in the bottom for better seal integrity and are sized for 3/4" conduit fittings. The cover is hinged on the left side with screw down latches on the other three sides. Inside the enclosure, all the electronics are mounted to a removable back plate. A field wire terminal block board (External Interface Board) with power ON/OFF switch is mounted to the right inside of the enclosure. Please see the assembly and installation drawings in Appendix D.

Figure 5-1

Transducer Interface Enclosure Block Diagram

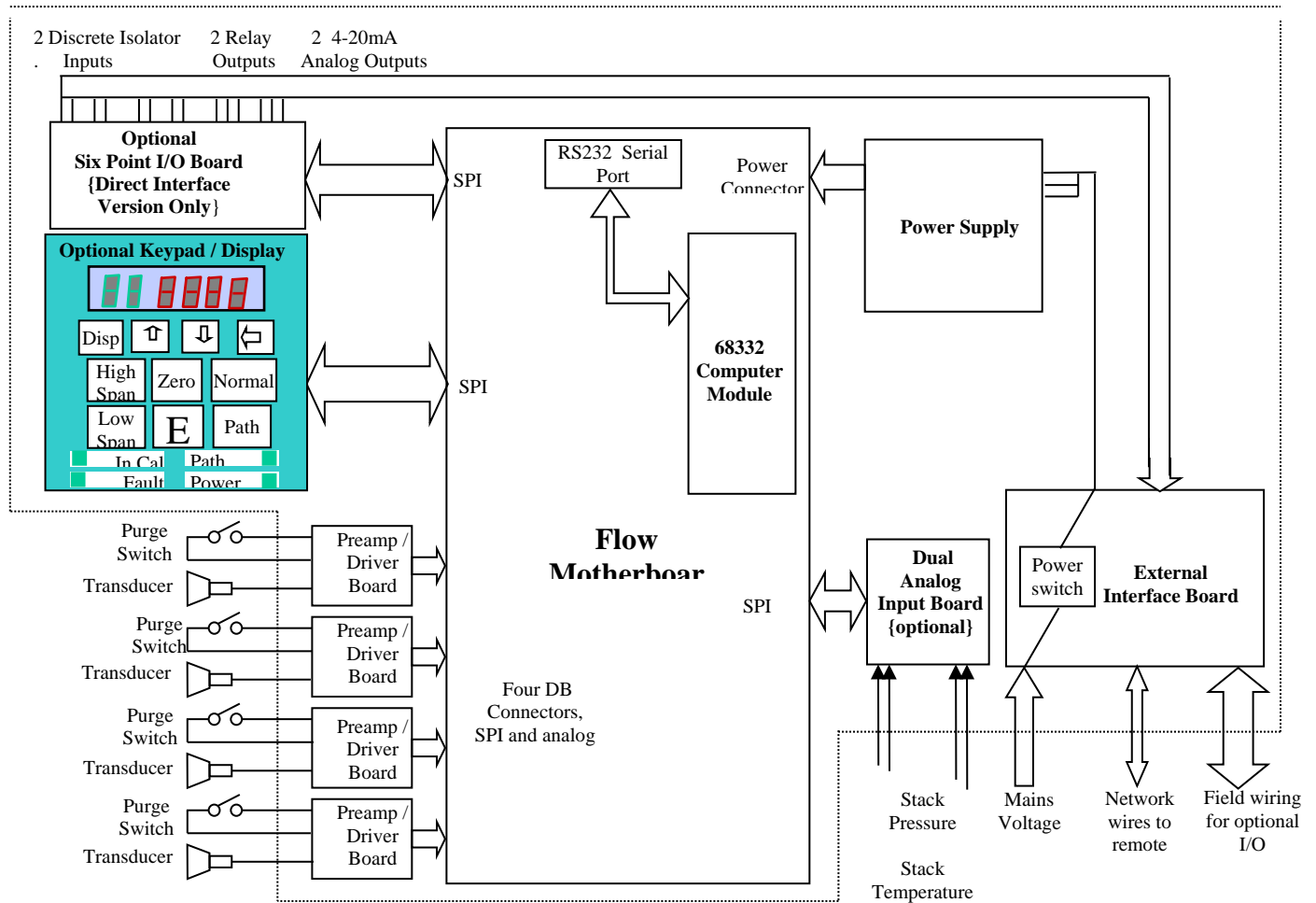

5.2 ELECTRICAL DESCRIPTION

The TIE can be powered with either 115 VAC or 230 VAC feeds. The power supply is auto ranging and will function normally with inputs from 85 VAC to 265 VAC, 50-60HZ. The power ON/OFF switch is located inside on the External Interface Board. This board's main purpose is to provide a place to land the field wiring. The terminal blocks are sized to handle 12 – 28 AWG wire.

The data cable to the Enhanced Remote Panel uses shielded two-wire cable to carry the serial data via a commercial communication protocol. The signals to and from each of the transducer probes are carried by a RG62 coax cable and a multi pair, individually shielded, 22 AWG, cable carries the purge on/off signal.

5.2.1 External Interface PC Board

The main purpose of the External Interface PC Board is to provide a connection point for the field wiring. It has three terminal blocks. TB1 is for landing the AC mains and TB2 is used to land the data cable network wires. If the optional Direct Interface (560DI) is incorporated into the system, the unused terminals of TB2 and all of TB3 are used to land the interface wires. A double pole power ON/OFF switch is also located here. The board has direct connections to the Power Supply Board, Flow Mother Board, and optional Six Point I/O Board.

Consult the Site Specification Data sheet of Appendix A for information on the configuration of your individual monitor.

5.2.2 Power Supply Board

The Power Supply Board is located in the upper right corner of the enclosure. It plugs directly into the Flow Mother Board. The power supply is auto ranging. It requires 85-265 VAC, 50-60 HZ input power and provides +15 VDC regulated, -15 VDC regulated, and +5 VDC regulated outputs.

5.2.3 Flow Mother Board

At the heart of the Flow Mother Board are two control devices a Field Programmable Gate Array (FPGA) and a self-contained computer processor module. The FPGA performs all of the low-level control functions of the transducer interface. The computer module is a stand alone, SBC 332 Processor Board that plugs directly into the Flow Mother Board. The computer module handles all calculations and higher level control/timing. Please refer to Fig 5-2.

The Flow Motherboard architecture is complex, as is the custom application software it runs. A detailed description of the board's electronics and software is beyond the scope of this manual. For ease of understanding, the Mother Board's function is described on a block diagram level.

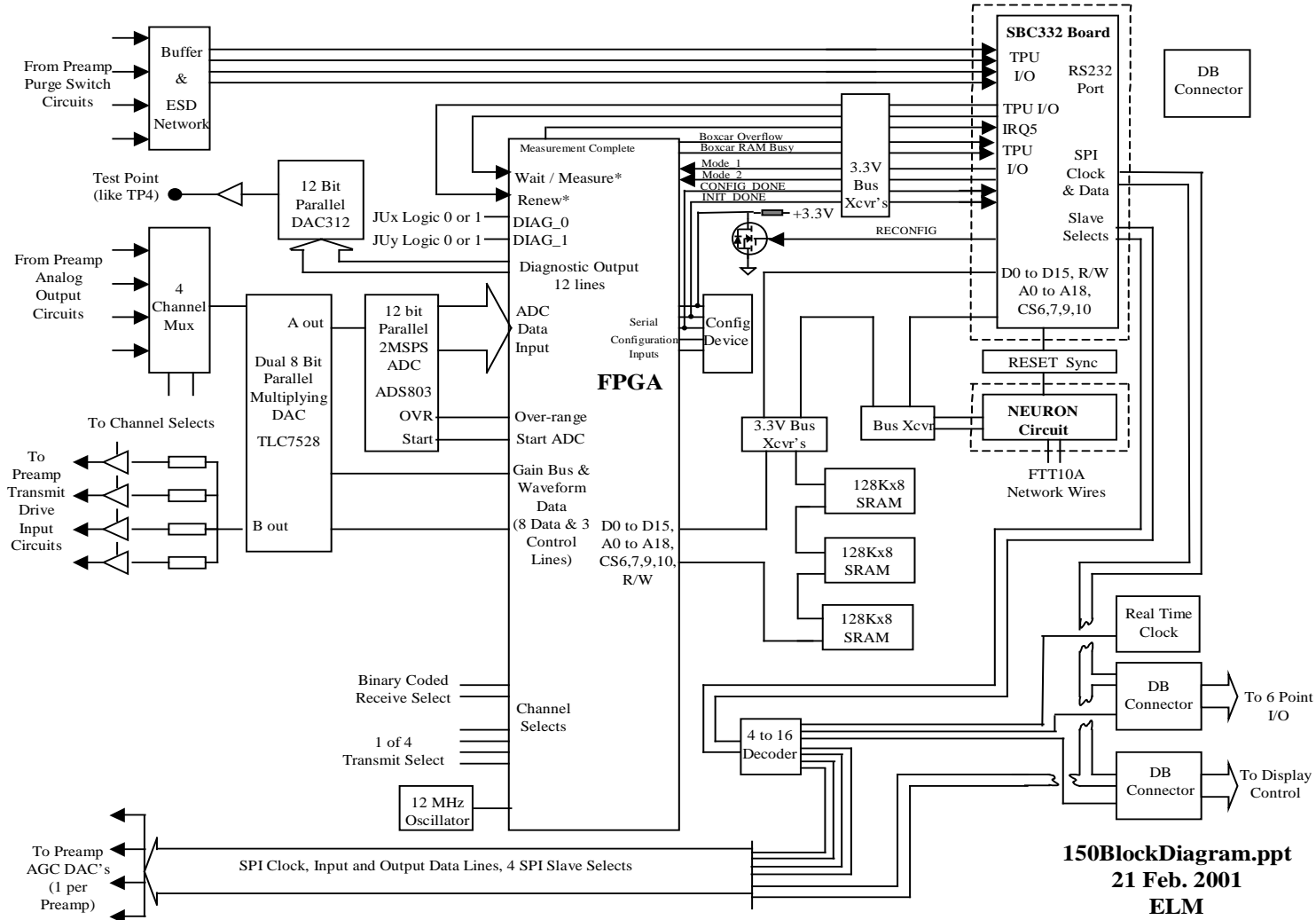

Figure 5-2
Flow Mother Board Block Diagram

5.2.3.1 Configuration Devices

The Flow Mother Board FPGA is SRAM-based; therefore its internal memory is volatile. Consequently, it must be configured each time power is cycled. This is done automatically with an IC known as a Configuration Device. The Configuration Device U5 is a flash memory that contains additional circuitry to control the serial loading of configuration data into the FPGA. The configuration data in U5 programs the gates and registers inside the FPGA to accomplish the board’s design functions. It is important to realize this configuration is not the same as the monitor’s calibration configuration, i.e. parameters such as Geometry Properties, Calibration Properties, etc., which are usually entered by menu selections via the Enhanced Remote Panel software.

The FPGA performs digital filtering on the incoming received signals. Since each transducer type has a different center frequency, a different Configuration Device is required to properly filter each one. There are three different types of Configuration Devices, one for each type of transducer. See Table 5-1.

Table 5-1
Configuration Device U5 versus Transducer Type

TRANSDUCER TYPE	REQUIRED CONFIGURATION DEVICE U5
ES	Labeled as X.50
LR003	Labeled as X.20
LR004 through LR007	Labeled as X.14

(where X is number that changes based on the firmware version of U5)

In the Enhanced Remote, the System Properties, Intrinsic Properties parameter Transducer Type can be selected via menu control. This selection must match the Configuration Device U5 or the monitor will not function. A Filter Mismatch fault will be generated if the Transducer Type selection does not match Configuration Device U5.

5.2.3.2 Transducer Drive Waveforms

The FPGA produces a digitized version of the ultrasonic tone burst wave packet required to drive the transducers. The FPGA sends a digital representation of the wave packet to the “B” half of a dual DAC where it is converted to an analog signal and steered to the appropriate preamp by the transmit select signals of the FPGA. Since this waveform is digitally created, it does not require tuning and is virtually free of temperature drift. Figures 5-3A and 5-3B are examples of typical waveforms for two different transducer types used in different applications.

Consult the Site Specification Data sheet of Appendix A for information on the transducer configuration of your individual monitor.

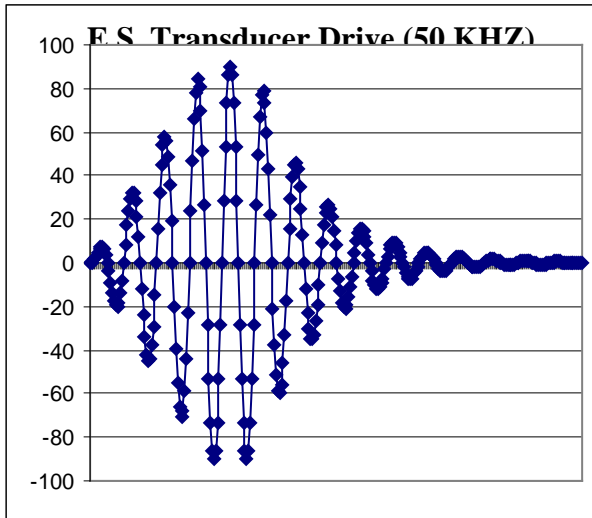
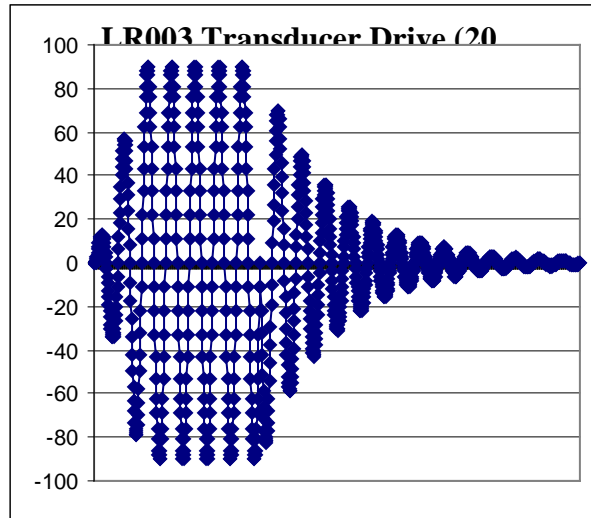
Figure 5-3A**Figure 5-3B**

Note: The scales of the “X” axes are not the same.

5.2.3.3 Receive Signal Select, Gain, Digitization, Integration and Storage

When the FPGA determines it is time to read the receive signal from a particular transducer/preamp it sends the appropriate channel select code to the four channel multiplexer. The multiplexer then places the desired analog receive signal on the input of the “A” half of a dual DAC. The DAC applies the appropriate gain that is determined by the FPGA to this signal and places the result on the input of a twelve bit Analog to Digital converter (ADC). The ADC begins doing a conversion when it receives a start signal from the FPGA. Each conversion takes 0.5 μ sec. At the end of each conversion the digital value is passed to the FPGA where it is filtered, rectified, and added to the appropriate boxcar in the RAM. Another start signal is then issued and the ADC starts another conversion cycle. This continues for 32,384 cycles creating a sixteen millisecond wide window of 0.5 μ sec filtered digital averages. The RAM has a separate boxcar window for each transducer. After the digitized window is complete the FPGA channel select requests a different transducer/preamp signal from the multiplexer and the ADC conversions begin forming the digital, (boxcar) window for that transducer. The channel select continues cycling through the transducers and adding conversions to the boxcars in the window until the desired integration time is over. This is typically 30 seconds. At the end of the integration period the FPGA sends a “Measurement Complete” signal to the 332 Processor. The 332 Board issues a “Wait” signal to the FPGA, while it reads the four windows of “Boxcar” data, and processes the data into time measurements and velocity readings. Then it begins the next sampling cycle for the duration of the integration period.

5.2.3.4 Diagnostic Waveforms Circuit

The Flow Mother Board has an important built in diagnostic feature. Eight different signals can be viewed from test point 21 (TP21) depending on the configuration of the diagnostic jumpers of JU8. The FPGA places the digital data selected by JU8 (positions A, B or C) on a twelve-bit buss that connects to a digital to analog converter (DAC). The DAC sends an analog representation of the data through a buffer to TP21. This gives the user a way to view complex data such as the filtered and integrated receive data that exists only in the digital realm.

Figure 5-4A

DIAG_2 (JU8C)	DIAG_1 (JU8B)	DIAG_0 (JU8A)	Diagnostic Output
0	0	0	A/D Output
0	0	1	Filter ABS
0	1	0	Boxcar (6--17)
0	1	1	Boxcar (7--18)
1	0	0	Boxcar (9--20)
1	0	1	Boxcar (10--21)
1	1	0	Boxcar (11--22)
1	1	1	Boxcar (12--23)

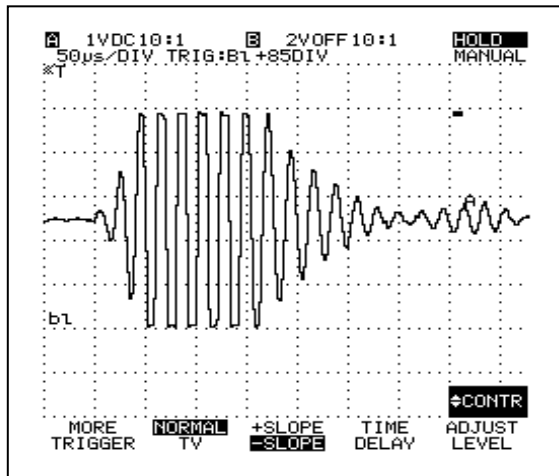

Typical A/D output waveform, Normal

Figure 5-4B

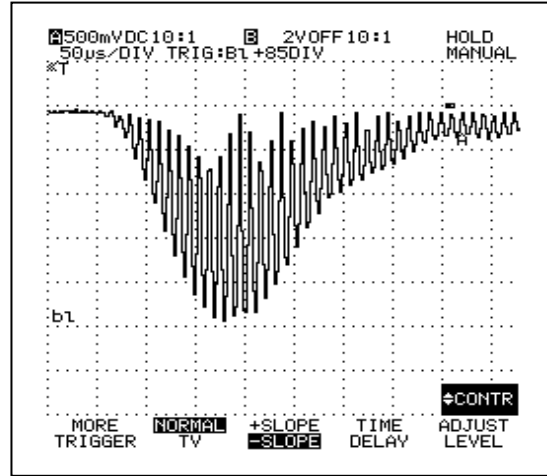

Typical filtered, absolute value waveform

Figure 5-4C

Note: The sample diagnostic waveforms above were taken from TP21 during normal mode with the scope triggered on TP34.

5.2.3.5 Bus Transceivers and Logic Level Differences

The digital components of the Flow Mother Board operate with three different logic levels. The FPGA's internal logic uses 2.5 VDC. Its I/O logic requires 3.3 VDC. The SBC 332 Processor and Neuron Circuit use conventional 5.0 VDC

logic. Bus transceivers are used to convert logic from one level to another wherever needed.

5.2.3.6 Purge Switch Circuits

The signals from the purge switch enter the Flow Mother Board through the Preamp Board connector. They are passed through an ESD/buffer network to the computer module. A logic LOW indicates normal purge air flow.

5.2.3.7 On Board D.C. Supplies

The Flow Mother Board has circuits to produce the following D.C. supply voltages: 2.5 VDC---Used for FPGA Core functions; 3.3 VDC---Used for FPGA I/O functions; 5.0 VDC---Used for analog functions; -5.0 VDC---Used for analog functions; 130 VDC---Used for short range transducer bias.

5.2.3.8 External Serial Data Connections

The Flow Mother Board supports both synchronous and asynchronous serial devices. All synchronous serial devices are for use by Ultraflow 150 components, most of which are on TIE circuit boards external to the Flow Mother Board.

The Flow Mother Board supports one RS232C asynchronous serial port for use with Teledyne Monitor Labs' PC to Modbus software. This port is accessible through DB9 connector J9.

5.2.3.8.1 Synchronous Serial Devices

The Flow Mother Board employs 11 synchronous serial device channels. The Serial Peripheral Interface (SPI) standard is used to convey data to the I/O devices. The Computer Module Board acts as the master SPI device and hence controls access. All of the devices are on external circuit boards with the exception of the real time clock. The devices are listed below.

- 1) Upstream Path A Preamp Gain
- 2) Downstream Path A Preamp Gain
- 3) Upstream Path B Preamp Gain (X Pattern only)
- 4) Downstream Path B Preamp Gain (X Pattern only)
- 5) Local User Interface LED Display (Optional)
- 6) Local User Interface Keypad (Optional)
- 7) Six Point I/O Analog Output DAC1 (Optional)
- 8) Six Point I/O Analog Output DAC2 (Optional)
- 9) Six Point I/O Isolator Inputs (Optional)
- 10) Six Point I/O Relay Outputs (Optional)
- 11) Real Time Clock (Internal to Flow Mother Board)

5.2.3.8.2 TIE Asynchronous Serial Port

Flow Mother Board DB9 connector J9 is an RS232C serial port. This is a three wire serial port that does not support frame control. A custom Modbus protocol is

used to communicate with an optional test and configuration program. The communication port parameters are listed in Table 5-2.

Table 5-2
TIE RS232C Serial Communication Parameters

BAUD RATE	STOP BITS	DATA BITS	PARITY
9600	1	8	NONE

5.2.3.9 Computer Module Board

The Computer Module is a stand-alone Processor Board that plugs horizontally into the Flow Mother Board. The Processor is an MC68332. The application software is loaded into two flash memory chips U1 and U5. Two SRAM's are used for working memory. The Computer Module reads the integrated receive window data from the Flow Mother Board RAM, and performs all of the time, velocity, flow and temperature calculations. It handles all of the calculations and controls all serial communication to and from the TIE. An RS232 serial port is supported by the computer module. The port runs a custom "Modbus" protocol. An optional software tool is available which allows the operator to communicate with the TIE through the serial port.

5.2.4 Preamp Boards

The TIE can control up to four transducers. Each transducer has a Preamp Board associated with it. There are two different types of Preamp Boards, the Electrostatic Preamp and the Flow Preamp Driver Board.

Consult the Site Specification Data sheet of Appendix A for information on the configuration of your individual monitor.

5.2.4.1 Electrostatic Preamp Driver Board

The Electrostatic Preamp Driver Board is used exclusively with the Electrostatic (50 KHZ) Transducers. It plugs into the preamp slots on the left side of the Flow Mother Board and connects directly to the transducer probe via a coax cable and a single twisted shielded pair cable. This board has circuits to bias the transducer, amplify and apply the transmit waveform, amplify the receive signal, and apply a digital gain to the receive signal. The purge switch signal is passed directly through the preamp to the Flow Mother Board.

5.2.4.2 Flow Preamp/Driver Board

This Preamp Board can be used on monitors with the Electrostatic or Long Range Transducers. However, it must be used in conjunction with an Ultraflow150 Flow Buffer Board. The Ultraflow 150 Flow Preamp/Driver Board also plugs directly into the preamp slots in the Flow Mother Board. It is connected to the Flow

Buffer Board in the junction box assembly by a coax cable and three twisted, shielded pair cable. The Flow Preamp/Driver Board has circuits to amplify the transmit waveform, amplify the receive signal, apply a digital gain to the receive signal, and bias the Electrostatic Transducer. Jumpers are provided to switch between Electrostatic and Long Range Transducers. The purge switch signal is passed directly through the preamp to the Flow Mother Board.

CAUTION: *Care must be taken to insure that the jumpers are in the correct position to avoid damage to the transducer.*

5.2.5 (Optional) Dual Analog Input Board

The Dual Analog Input Board is an optional device intended to interface external temperature and pressure signals into the system. This is necessary for monitors that must correct the readings to standard conditions. The Dual Analog Input Board can take three types of temperature inputs; RTD, 4-20_{ma} current loop, or DC voltage loop. It can take three types of barometric pressure signals; a custom Teledyne Monitor Labs module, a 4-20_{ma} current loop, or a DC voltage loop. The board plugs into a connector on the bottom of the Flow Mother Board. The information is transferred via Serial Peripheral Interface (SPI).

5.2.6 (Optional) Local User Interface Key Pad and Display Assembly

The optional Local User Interface (Standard on a 560DI) is designed as a basic data display and mode command station for the operator when on the stack. It does not have the ability to make parameter changes. It can only request data for display and switch the monitor from one operational mode to another. (See Section 4.2.2.)

The assembly has a six digit LED display and a ten-button key pad. There are also four LED indicator lights for Fault, In Calibration, Path displayed and Power on/off. The leftmost two digits of the display are green and indicate the bank and the number of the parameter to be displayed. The parameters are grouped by banks: User bank (Table 5-3A), Service bank (Table 5-3B), and Auxiliary bank (Table 5-3C). The following parameter tables and “Individual Button Function” section define how to use the interface.

Table 5-3A
U Bank (User Data Bank)

Code	Description, (Inst/Avg), Units	E Button Action
U0	Actual Velocity, Instantaneous, ft/s or m/s	NO EFFECT
U1	Actual Velocity, Average, ft/s or m/s	NO EFFECT
U2	Actual Volume, Instantaneous, various units	EXPONENT
U3	Actual Volume, Average, various units	EXPONENT
U4	Standard Volume, Instantaneous, various units	EXPONENT
U5	Standard Volume, Average, various units	EXPONENT
U6	Span High Volume, Instantaneous, various units	EXPONENT
U7	Span High Volume, Average, various units	EXPONENT
U8	Span Low Volume, Instantaneous, various units	EXPONENT
U9	Span Low Volume, Average, various units	EXPONENT
UA	Zero Volume, Instantaneous, various units	EXPONENT
UB	Zero Volume, Average, various units	EXPONENT
UC	Mode, dimensionless	NO EFFECT
UD	Primary Status, dimensionless	EXTENDED
UE	Extended Status, dimensionless	EXTENDED

Table 5-3B
S Bank (Service Data Bank)

Code	Description, (Inst/Avg), Units	E Button Action
S0	S/N Ratio, Downstream	NO EFFECT
S1	S/N Ratio, Upstream	NO EFFECT
S2	Peak RAM Count, Downstream	EXTENDED
S3	Peak RAM Count, Upstream	EXTENDED
S4	Calculated RAM Count, Downstream	EXTENDED
S5	Calculated RAM Count, Upstream	EXTENDED
S6	Preamplifier Gain, Downstream	NO EFFECT
S7	Preamplifier Gain, Upstream	NO EFFECT
S8	Digital Gain, Downstream	NO EFFECT
S9	Digital Gain, Upstream	NO EFFECT
SA	TD, Downstream	EXTENDED
SB	TD, Upstream	EXTENDED
SC	Span High Offset TD	EXTENDED
SD	Span Low Offset TD	EXTENDED
SE	R Factor	EXPONENT

Table 5-3C
A Bank (Auxiliary Data Bank)

Code	Description, (Inst/Avg), Units	E Button Action
A0	Medium Internal Temperature, Instantaneous, deg. C or F	NO EFFECT
A1	Medium Internal Temperature, Average, deg. C or F	NO EFFECT
A2	Medium External Temperature, Instantaneous, deg. F or C	NO EFFECT
A3	Medium External Temperature, Average, deg. F or C	NO EFFECT
A4	Speed of Sound, Instantaneous, ft/s or m/s	EXTENDED
A5	Speed of Sound, Average, ft/s or m/s	EXTENDED
A6	Time of Flight, Downstream, seconds	EXPONENT
A7	Time of Flight, Upstream, seconds	EXPONENT
A8	Medium Pressure, Instantaneous, inches of Hg or KiloPascals	NO EFFECT
A9	Medium Pressure, Average, inches of Hg or KiloPascals	NO EFFECT

5.2.7 Individual Button Function (When Pressed by Themselves)



When pressed and released it has one of three actions:

NO EFFECT: Nothing happens.

EXPONENT: The VALUE digits of the LED display show the exponent portion of the floating-point number corresponding to the bank code. When pressed and released again, the VALUE digits of the LED display show the mantissa of the number and the CODE digits show the bank code.

EXTENDED: The value digits of the LED display show the least significant portion of the integer number corresponding to the bank code. When pressed and released again, the VALUE digits of the LED display alternately display "PUSH" "---E" and the CODE digits show the bank code.



DISPLAY: Increments the variable # displayed, U0 becomes U1, F0 becomes F1, etc.



INCREMENT: No effect.



DECREMENT: No effect.



LEFT: No effect.



SPAN HIGH: Initiates a SPAN HIGH calibration.



ZERO: Initiates a calibration ZERO.



NORMAL: Places instrument in NORMAL mode.



PATH: Since each TIE has two measurement paths (A and B) but only one display, a means is needed to toggle the single display between Path A data and Path B. This button performs this function. The A=ON/B=OFF LED moves in unison with the state of the data display.



SPAN LOW: Initiates a SPAN LOW calibration.

5.2.8 Combinations of Buttons

SPAN HIGH * ZERO: Initiates a Calibration Cycle.

SPAN LOW * ZERO: Initiates a Calibration Cycle.

DISPLAY*LEFT: Toggles the display from User data (U) to Service data (S) and Auxiliary data (A) banks when pressed and held for about a second. After 10 minutes with no keypad activity, the display defaults back to the User data bank (U). Repeat functions are supported for this combination of buttons.

DISPLAY*INC: Increments the variable number displayed, i.e., U0 becomes U1, F0 becomes F1, etc. Repeat functions are supported for this combination of buttons.

DISPLAY*DEC: Decrements the variable number displayed, i.e., U5 becomes U4, S5 becomes S4, etc. Repeat functions are supported for this combination of buttons.

5.2.9 (OPTIONAL) 6PT I/O PC BOARD FOR 150DI

The Six Point I/O Board is an optional device intended to provide a low cost Direct Interface feature to the Ultraflow 150DI where analog output and control signals are supplied directly from the Transducer Interface Enclosure (TIE) Assembly. (See section 3.5) This board is located below the local user interface keypad and is accessible by removing the two thumb knobs on the LUI and swinging to the left.

6.0 ENHANCED REMOTE PANEL W / MULTI I/O MODULE (NOT SUPPLIED WITH 560DI)

6.1 OVERVIEW

The Enhanced Remote Panel is menu driven. It features a touch sensitive keypad, a 4 ½” (11.4 cm) LCD display, key lockout, RS-232 and RS-422/485 serial communication capability, and a commercial network communication node. The Multi I/O Board has eight relay outputs, eight isolated digital inputs, and four individually isolated analog outputs.

6.2 MECHANICAL DESCRIPTION

The Enhanced Remote Panel uses a modular design. The components of the display are mounted in a 19” rack mountable enclosure. The enclosure is 5 ¼” (13.3 cm) high, x 8” (20 cm) deep, x 16 9/16” (42.1 cm) wide. There are two #8-32 tapped holes on each side for slides if desired.

All external connections are made from the back panel with pluggable connectors. Access to the inside of the unit is through a removable top panel. The top panel is removed by taking out four screws.

Inside the enclosure there are seven circuit boards, a power entry module, several interconnect cables, and the Liquid Crystal Display (LCD) board. The LCD Driver Board is integral to the display and the keypad is built into the front panel. The Terminal Block PC Board mounts to the back panel. The other five boards mount off of the bottom panel in a stacked arrangement. The Mother Board, Multi I/O Board, and Power Supply Board mount on standoffs and are interconnected by cables. The Computer Module Board and the LonWorks® Board mount directly into sockets on the Mother Board.

Modules of the Enhanced Remote Panel:

Mother Board

Computer Module Board (mounts on Mother Board)

LonWorks® LTM-10 Board (mounts on Mother Board)

Terminal Block PC Board

Power Supply Board

Multi I/O Board

LCD w / Driver Board

Power Entry Module

Keypad/Front Panel Assembly

6.3 ELECTRICAL DESCRIPTION

6.3.1 Input Power Requirement

The Enhanced Remote Panel has been designed to operate over a wide range of international power supply ranges and frequencies without the need for modifications or adjustments. (*See Section 2.0 of this manual for input power specifications.*) The internal D.C. supply is auto-ranging and automatically adjusts for the power mains voltage.

6.3.2 Circuit Description (Overview)

The Enhanced Remote Panel Mother Board with Multi I/O Board are two separate networked devices mounted in a single package: the Enhanced Remote Panel Mother Board node (hereafter referred to as the Enhanced Remote Display) and Multi I/O Board node (hereafter referred to as the Multi I/O Board). Each have independent software and a unique network address. They share a common power supply and chassis. The Enhanced Remote Display acts as the operator interface. The Multi I/O Board is the peripheral hardware interface.

6.3.2.1 Liquid Crystal Display (LCD)

The display is a graphics capable, 240x128 pixel, back-lit LCD. The Display Driver Board is integral with the LCD and communicates to the Mother Board via ribbon cable. The contrast and back-light brightness are adjustable from the keypad.

6.3.2.2 Keypad

The Keypad is a light touch, membrane switch array. It is built into the front panel assembly and connects directly to the Mother Board via a ribbon cable.

6.3.2.3 Front Panel LED's

The Power, Fault, and Alarm LED's are also integral to the front panel assembly. They are connected to, and driven by, the Mother Board via a six pin ribbon cable (J₃).

6.3.2.4 Security Key Switch

The Security Key Switch is functionally in parallel with the administrator password. Protected variables can be unlocked with the administrator password or Key Switch.

6.3.2.5 Power Supply Board

The Power Supply Board produces the +5 VDC logic power for the Enhanced Remote Panel. It has two connectors - one for input and one for output. The input wires come from the input power module that contains the line cord connector power switch, and initial filtering. Surge protection and fusing are located on the board.

6.3.2.6 Terminal Block P.C. Board

The Terminal Block PC Board mounts to the rear panel and handles all I/O connections. It has ten connector plugs mounted on the outside that extend through the metal panel. Incoming wires terminate in the female half of the connector with the push of a screwdriver. This type of connector allows the wires to be removed one wire at a time or by connector group.

6.3.2.7 Enhanced Remote Panel Mother Board

The Enhanced Remote Panel Mother Board has two microprocessors, a 68332, and an LTM-10. Each is laid out on a separate Daughter Board that plugs horizontally into the Mother Board. The Mother Board has circuits to perform the following:

- ❑ Interface the two processors
- ❑ Buffer the data bus
- ❑ Adjust contrast and brightness outputs to the display
- ❑ Drive and buffer the keypad
- ❑ Drive the FTT10A network communication port
- ❑ Electrostatic Discharge (ESD) protection for all I/O's
- ❑ Drive the front panel LED's for Fault and Alarm
- ❑ Communicate with the display
- ❑ Provide -20 VDC for the LCD

6.3.2.8 RS-232 and RS-422/485

A simple serial communication interface for monitoring of network variables is provided. The user can use a standard terminal emulator program on a PC to communicate with the panel. Communication is provided on both the RS-232 and RS-422 ports. The RS-422 port can be converted to a RS-485 port with an

internal jumper located on the Mother Board. However, the RS-485 port communication protocol does not support addressability.

The communication parameters of both ports are fixed. They are listed in Table 6-1.

Table 6-1

BAUD RATE	DATA BITS	STOP BITS	PARITY
9600	8	1	N

The protocol operates in a polled mode only, i.e., the user must issue a request in order for the Enhanced Remote Panel to transmit data. Broadcast mode is not supported.

The user request protocol is an ASCII string of the format

nnnx<CR>

where nnn is a number from 1 to 511 corresponding to the requested variable, <CR> is the carriage return character and x is one of two command characters (? or \$). The nnn values of 255 and 511 have special significance (see below). All other characters are ignored and will cause the Enhanced Remote Display serial port to respond with an error message. A time delay of more than 10 seconds between characters will cause the previously sent characters to be discarded.

Table 6-2 is a summary of the possible user requests followed by some examples.

Table 6-2

USER REQUEST	ENHANCED REMOTE DISPLAY SERIAL PORT RESPONSE
nnn?<CR>	Send variable nnn
255?<CR>	Send all TIE1 variables sequentially
511?<CR>	Send all TIE2 variables sequentially
nnn\$<CR>	Send 15 consecutive variables starting with variable nnn-14 and ending with nnn

RESPONSE FORMAT EXAMPLES

REQUEST: 1?<CR>
RESPONSE: 1 TIE1_DATE: 16-Jul-02<CR><LF>

REQUEST: 123?<CR>
RESPONSE: 123 StdFlowVolInstTIE1A: -0.736057<CR><LF>

REQUEST: %67*<CR>
RESPONSE: UNRECOGNIZED COMMAND<CR><LF>

REQUEST: 534?<CR>
RESPONSE: INVALID VARIABLE NUMBER<CR><LF>

Figure 6-1
Mother Board Block Diagram, 1803-0200

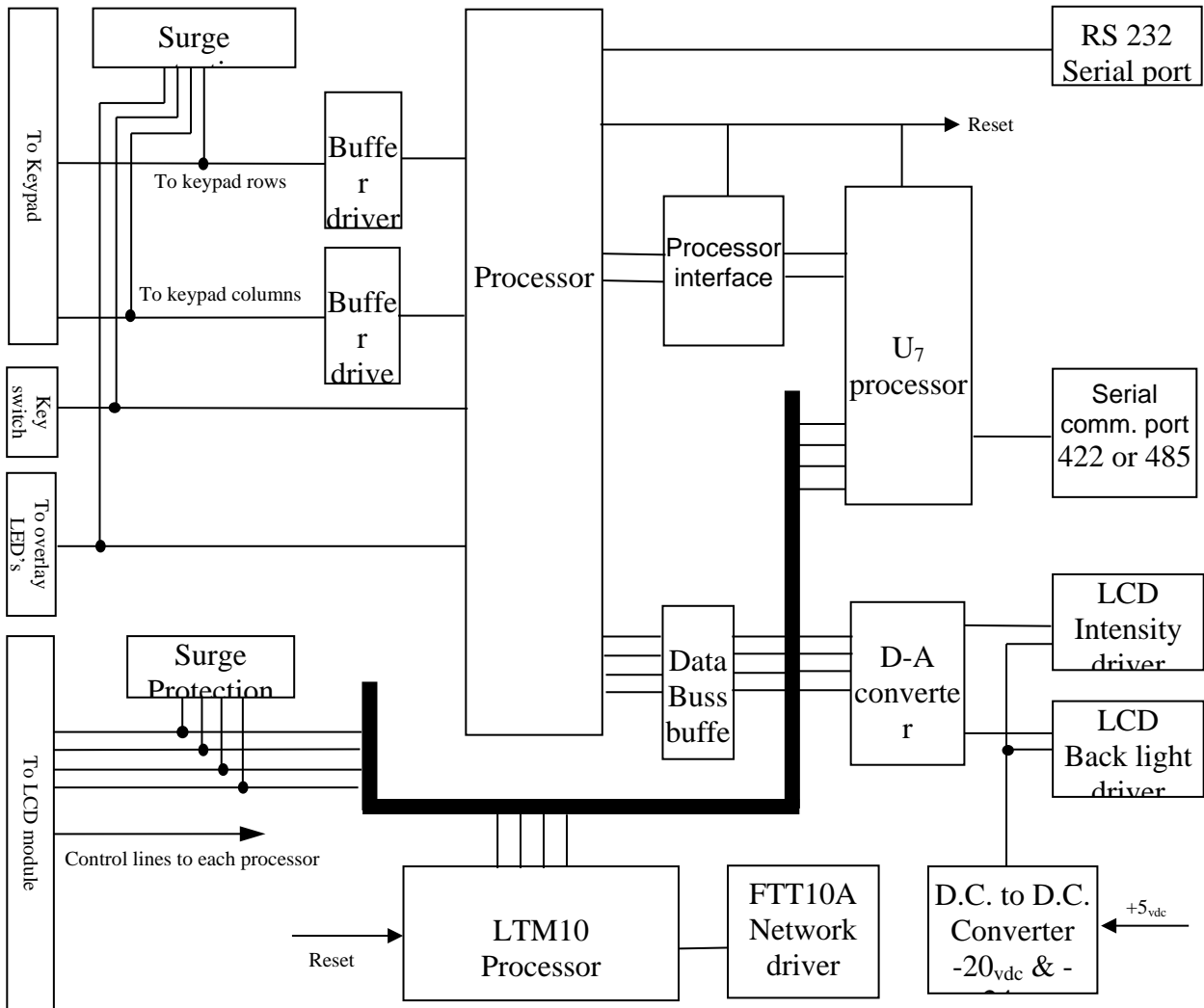

Table 6-3A

Enhanced Remote Display Mother Board Jumper Definitions

Jumper #	Selections							Functional Description
JU1	IRQ1	IRQ2	IRQ3	IRQ4	IRQ5	IRQ6	Out	Selects IRQ for reset signal
JU2	IRQ1	IRQ2	IRQ3	IRQ4	IRQ5	IRQ6	Out	RS422/485 Receive IRQ
JU3	UART			TPU				Selects where to send received data
JU4	UART			TPU				Selects UART or TPU data for transmit to J ₆
JU5	UART		TPU		422			Selects handshake signal or full time on
JU6	A – B = single			B – C = double				Selects single or double termination of network
JU7	A – B = terminated			B – C = not terminated				Selects if network is terminated at remote or not
JU8	-20V			-24V				Selects drive voltage for LCD contrast adjustment

Table 6-3B

68332 Processor, SBC332 Board, Jumper Definitions

Jumper #	Selections		Functional Description	
J2A	1 -- 2	2 – 3	J2A, through J2F configure the Computer Module Board for the type of memory used. Standard settings are highlighted.	
J2B	1 -- 2	2 – 3		
J2C	1 -- 2	2 – 3		
J2D	1 -- 2	2 – 3		
J2E	1 -- 2	2 – 3		
J2F	1 -- 2	2 – 3		
J3	1 -- 2 = Enabled	2 -- 3 = Disabled	J3 enables or disables the 68332's watchdog timer	
J9	1 -- 2	2 -- 3	1-2 = 1200 _{ms} timeout	J9 selects the length of time the watchdog timer waits
J7	IN		Out	J7 puts in or takes out the RAM supercap for backup
J10	IN		Out	Selects the serial port outputs of the 68332
J12	IN		Out	Selects the serial port outputs of the 68332

- NOTES:**
1. J1, J4, J5A, J5B, J6, and J11 on the Computer Module Board are actually connectors. **NEVER jumper together any of the pins on these headers.**
 2. Bold print or shading indicates the standard selection.

6.3.2.9 Multi I/O Board (Hardware)

The Multi I/O Board is a peripheral hardware interface. It communicates with the other devices in the system via a network interface. It gathers information from the TIE(s) and the Enhanced Remote Display via the network. It processes this information together with its digital inputs and site specific configuration to control its outputs.

The Multi I/O is capable of driving eight digital outputs (dry relay contacts) and four analog outputs. It can read up to eight digital inputs. The digital inputs are jumper configurable to be either dry contacts or 0 – 5 VDC signals. Dry contacts are standard.

The analog outputs are jumper configurable to be 4 – 20 mA, 0 – 20 mA, or 0 – 24 mA current loop signals. (0 – 20 mA) is the standard jumper setting, though the standard current output range is 4mA to 20mA. The standard jumper setting allows values less than 4mA to be transferred to a data collection device. This allows the 4mA level to function as a “live zero”. Test points are provided for measuring output current. See Jumper and Test Point Tables 6-4A and 6-4B.

Table 6-4A

Multi I/O Jumper Definitions

Jumper #	Selections			Functional Description					
	4--20 _{ma}	0--20 _{ma}	0--24 _{ma}						
JU1	1	0	1	Jumpers JU ₁ & JU ₂ configure the range of the analog outputs for channel #1.					
JU2	0	1	1						
JU3	1	0	1	Configures the range of analog output #2					
JU4	0	1	1						
JU5	1	0	1	Configures the range of analog output #3					
JU6	0	1	1						
JU7	1	0	1	Configures the range of analog output #4					
JU8	0	1	1						
	Dry Contact		5 _{vdc} Digital						
JU9	1-2-3	1-2-3	1-2-3	Configures digital input #1 hardware to work with dry contact or 5 _{vdc} logic signals					
JU10	1-2-3	1-2-3	1-2-3	Configures digital input #2 hardware.					
JU11	1-2-3	1-2-3	1-2-3	Configures digital input #3 hardware.					
JU12	1-2-3	1-2-3	1-2-3	Configures digital input #4 hardware.					
JU13	1-2-3	1-2-3	1-2-3	Configures digital input #5 hardware.					
JU14	1-2-3	1-2-3	1-2-3	Configures digital input #6 hardware.					
JU15	1-2-3	1-2-3	1-2-3	Configures digital input #7 hardware.					
JU16	1-2-3	1-2-3	1-2-3	Configures digital input #8 hardware.					
	Ram 128K	Ram 32K	ROM 128K	ROM 64K	ROM 32K	Flash 128K	Flash 64K	Flash 32K	
JU17	A	A	B	B	B	B	B	B	Jumpers JU ₁₇ & JU ₁₈ together, select the type of memory chips to be used.
JU18	D	D	C	C	B	C	C	A	
JU19	IN-----OUT Double terminated		IN-----OUT Single terminated		Selects whether the network termination will be single or double termination. This is usually done elsewhere				
JU20	IN-----OUT Out = unterminated		IN-----OUT IN = terminated		Terminates the network if necessary. This is usually done elsewhere.				
JU21	1 2 3		2 3		K1 Contact: 2 3 = NO 1 2 = NC				
JU22	1 2 3		2 3		K2 Contact: 2 3 = NO 1 2 = NC				
JU23	1 2 3		2 3		K3 Contact: 2 3 = NO 1 2 = NC				
JU24	1 2 3		2 3		K4 Contact: 2 3 = NO 1 2 = NC				
JU25	1 2 3		2 3		K5 Contact: 2 3 = NO 1 2 = NC				
JU26	1 2 3		2 3		K6 Contact: 2 3 = NO 1 2 = NC				
JU27	1 2 3		2 3		K7 Contact: 2 3 = NO 1 2 = NC				
JU28	1 2 3		2 3		K8 Contact: 2 3 = NO 1 2 = NC				

- NOTES:**
1. For exact jumper positions as shipped see "Site Specification Data sheets" (Appendix A).
 2. Bold print indicates the standard selection.

Table 6-4B
Multi I/O Test Point Descriptions

Test Point #	Functional Description	Output
TP1	24 _{vdc} isolated drive voltage for analog output #1. Referenced to TP ₂	Output #1
TP2	GND reference for TP ₁ and all points within #1 output circuit	
TP3	TP ₃ & TP ₄ are on opposite sides of a 100Ω resistor that is in series with the output #1 current loop. Measure the DC voltage across these test points and divide by 100 to calculate the actual output current of channel #1.	
TP4		
TP5	24 _{vdc} isolated drive voltage for analog output #2. Referenced to TP ₆	Output #2
TP6	GND reference for TP ₅ and all points within #2 output circuit	
TP7	TP ₇ & TP ₈ are on opposite sides of a 100Ω resistor that is in series with the output #2 current loop. Measure the DC voltage across these test points and divide by 100 to calculate the actual output current of channel #2.	
TP8		
TP9	24 _{vdc} isolated drive voltage for analog output #3. Referenced to TP ₁₀	Output #3
TP10	GND reference for TP ₉ and all points within #3 output circuit	
TP11	TP ₁₁ & TP ₁₂ are on opposite sides of a 100Ω resistor that is in series with the output #3 current loop. Measure the DC voltage across these test points and divide by 100 to calculate the actual output current of channel #3.	
TP12		
TP13	24 _{vdc} isolated drive voltage for analog output #4. Referenced to TP ₁₄	Output #4
TP14	GND reference for TP ₁₃ and all points within #4 output circuit	
TP15	TP ₁₅ & TP ₁₆ are on opposite sides of a 100Ω resistor that is in series with the output #4 current loop. Measure the DC voltage across these test points and divide by 100 to calculate the actual output current of channel #4.	
TP16		

6.4 OPERATIONAL DESCRIPTION—Menu Structure and User Interface

The Enhanced Remote Panel is menu driven. Operational and configuration parameters are viewed and changed through the display menu screens. The system configuration parameters are password protected. Protected screens can be accessed with the supervisor password or the Security Key Switch. Operational and test parameters may be viewed and/or changed by scrolling through the menus using the “↑”, “↓”, “Page Up”, “Page Down”, “ESC”, and “↵” keys. The functions of these keys are described on each menu screen. The ESC key will return you to the previous menu. Password protected screens will prompt for the password before displaying the screen. To use the Security Key Switch it must be in the ON position *before* that screen is selected.

6.4.1 Memory Test

The Memory Test runs at power up before the logo screen is displayed. It tests all the used areas of the RAM ICs. If they pass, a message is briefly displayed on the screen before the logo. If either one fails, a message indicating which chip failed remains on the screen and the CPU halts.

6.4.2 Main Display Screen

This is the screen that is typically displayed during normal operation. The screen has a total of twelve pages accessible by the “Page Up” and “Page Down” keys. There are two pages for each TIE/path. One of the two pages has large block numbers appropriate for continuous display. The other page has additional data for the TIE/path of interest. The Path “AB” screen displays the “OR-ed” status words and averages of the Path A and Path B data. No displayed parameters can be changed from these screens.

All parameters are updated at the end of each integration period. Instantaneous parameters are updated at the end of each integration period while in the appropriate mode. Average parameters will be updated at the end of the last integration period specified in the average. The STATUS text and STATUS code fields are updated immediately on any change in the monitor status. If multiple malfunctions are indicated, you can scroll through the STATUS text field errors by pressing either arrow button (↓ or ↑) once. After scrolling is completed the STATUS text field will stop and continuously display the most significant error. The NET STATUS field will display the status of network communication between the TIE and the display node. The PRIMARY and EXTENDED STATUS fields display various abnormal status conditions from the TIE.

The TIE#1 Path “A” display page is the default on power up and reset. This screen and its pages are at the top of the menu structure. All other screens can be accessed through these pages by moving down through the menu choices. From any one of the twelve pages of this display press the “↵” key to view the first level “Main” menu. The ESC key will bring you back up to the Main Display screens.

Figure 6-2
Ultraflow 150 Menu Tree

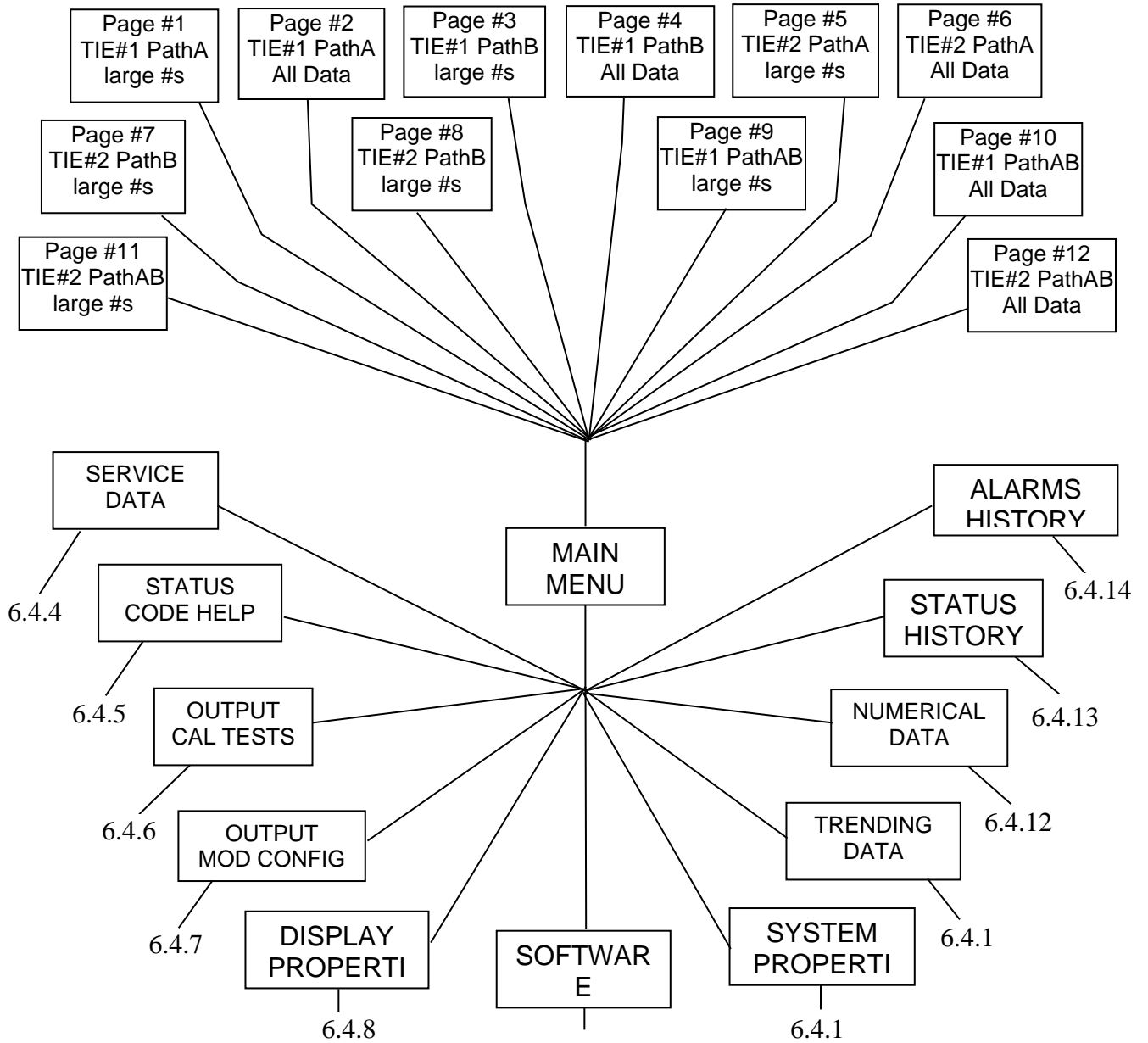

Note: Each submenu branch is explained in the indicated section.

6.4.3 Main Menu Screen

This is the first level of the menu structure. From this screen you can choose one of the submenus that lead to the information of interest. For a detailed description of the information available under a particular submenu refer to the section indicated by the figure above. To select a

particular submenu use the UP and DOWN arrow keys to highlight the selection then press the “↵” key to select. This will bring up the next menu screen as described in the appropriate section. The ESC key will take you back to the previous screen. Pressing the ESC key from the Main Menu screen will take you back to the Main Display, page #1.

6.4.4 Service Data Menu

Grouped under the Service Menu are various parameters that are useful in accessing the performance of each TIE and Path within the monitor. All data in this menu is read only. It is grouped into three categories, “FUNDAMENTAL DATA”, “ADVANCED DATA”, and “NETWORK CONFIG DATA”. To view this data select SERVICE DATA from the main menu by using the arrow keys and press ENTER. This will bring up the TIE/Path selection screen. Choose the TIE/Path you want to view with the arrow keys, and press ENTER. This will bring up the Data Group selection screen. Choose the group you wish to look at and press ENTER. The parameter names and values will appear on the display. The screen is configured to update live. Each time new data is received at the end of the sample integration cycle it is posted to the screen.

Within the NETWORK CONFIG DATA screen you can choose different indexed segments of the network variables for display. This information is for factory level troubleshooting only. All information from this screen is available to the operator elsewhere in the menu structure.

Figure 6-3

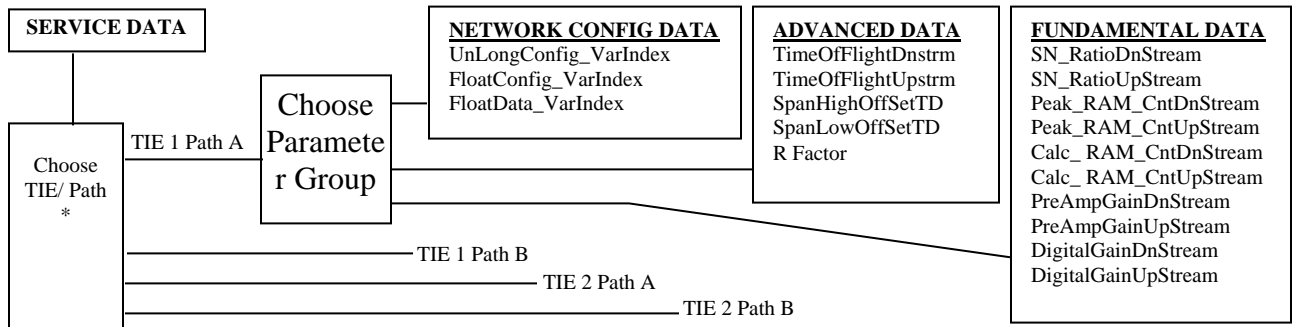

*Note: The “AB Paths” are not supported here. They represent calculated information and have no Service data behind them.

6.4.5 Status Code Help

This screen is view only. No password is required. The information displayed is useful in determining the status of the monitor. The screen contains the five-digit STATUS word and a decoded list of the individual status conditions. To view this screen select STATUS CODE HELP from the MAIN MENU by using the arrow keys and press ENTER. Choose the TIE/Path you want to view with the arrow keys, and press ENTER. This will bring up the PRIMARY/EXTENDED STATUS selection screen. Make a selection with the arrow keys and press ENTER. This brings up the STATUS CODE HELP screen. It has two pages. Switch from page one to page two with the “Page Up/Page Down” keys. Press the ESC key to leave the screen. The individual codes are additive. If a SPAN HIGH-CAL BAD and SPAN LOW-CAL BAD are active at the same time the STATUS WORD would be “6000”.

Figure 6-4

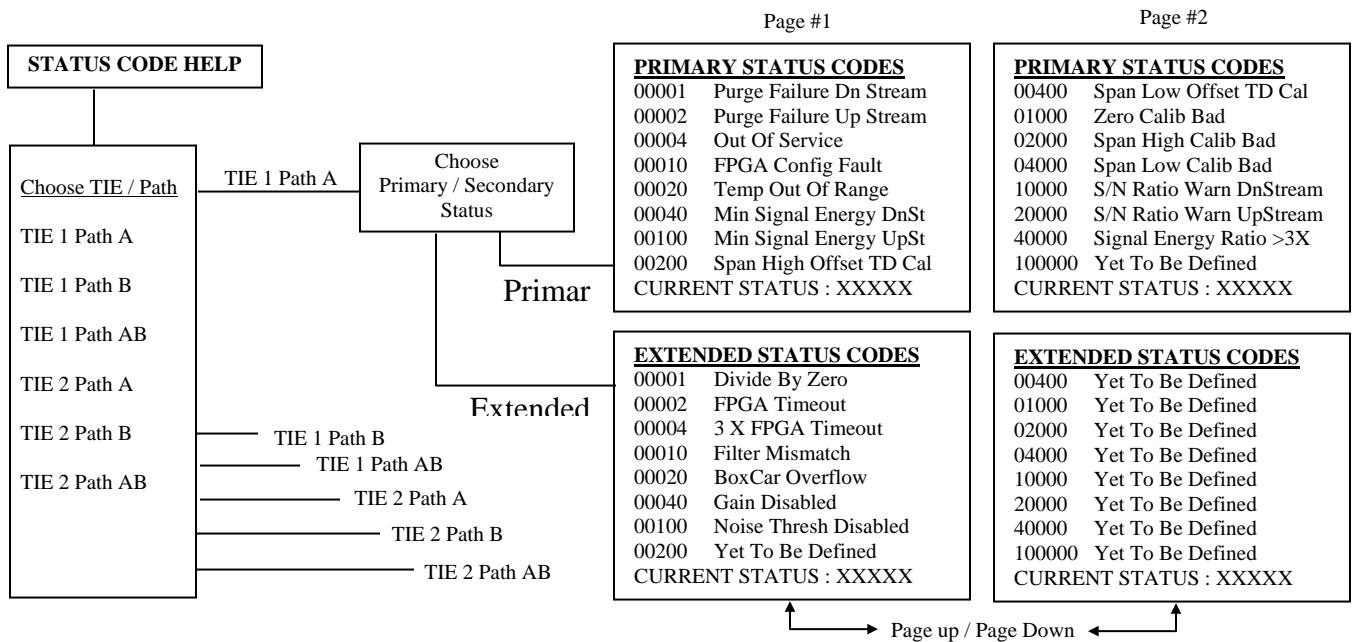

Note: There are too many potential status codes to combine into one six-digit octal number. The EXTENDED STATUS is simply a second six-digit octal number to handle the additional status.

6.4.6 Output Cal Tests

This is a password protected change screen. It allows you to command the system into different modes of operation. When the screen comes up, the COMMAND MODE line will be highlighted. Scroll through the modes

by pressing the “Page Up” and “Page Down” keys until the desired mode appears. Press ENTER to move the highlight bar to the “SEND THIS COMMAND” line then press ENTER to send the mode change request. The highlight bar will move back to the COMMAND MODE line.

The upper half of the screen displays and continuously updates the Instantaneous Flow Volume, the mode of the TIE, and the Multi I/O output mode. This allows the operator to monitor these parameters while the system is executing the mode change request.

The TIE and Multi I/O respond differently to each mode change request. Also the system reacts differently when entering and exiting certain modes. Refer to Table 6-5, Mode Change Request Table, for more information.

Figure 6-5

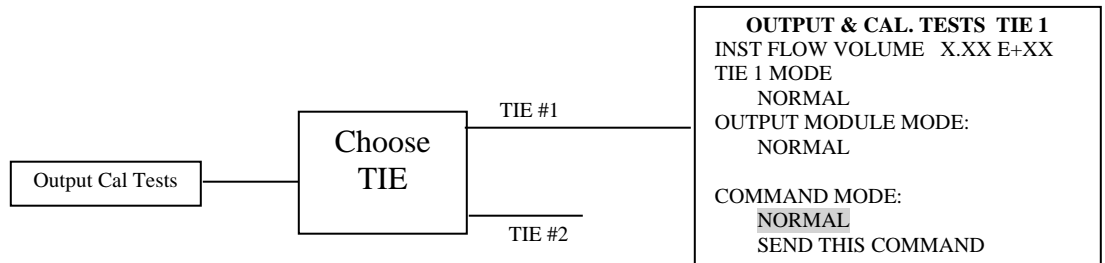

Table 6-5

Mode Change Request Table

Mode	TIE Function	Multi I/O (MIO) / Analog & Digital Output Function
NORMAL <i>Initiated by: Enhanced Remote Panel, Local User Interface, or System Clock</i>	When the TIE sees a NORMAL mode change request it goes into a NORMAL-ACQUIRE mode at the beginning of the next integration period and sends its mode out on the network. This mode will last for the number of integration periods specified in the averager. At the end of NORMAL-ACQUIRE the TIE will indicate NORMAL mode. The TIE will continue in this mode until it gets another mode change request.	The analog outputs will trend from whatever mode data they were displaying before, to the data that they are configured for during the NORMAL mode. The MIO mode follows the TIE mode not the request. The TIE changes modes based on the request. At the end of the TIE's first integration period in NORMAL-ACQUIRE the MIO will update its mode and relay statuses to match the NORMAL-ACQUIRE mode. Likewise at the end of the first period of NORMAL data the MIO will update its mode and relay statuses to match. The MIO mode always lags the TIE mode by one period because data is sent at the end of the integration period. Note : Data is not considered valid emission data during the NORMAL-ACQUIRE mode. See timing diagram.

SECTION 6.0, ENHANCED REMOTE PANEL W/MULTI I/O MODULE

<p>SPANHIGH <i>Initiated by: Digital Inputs, Enhanced Remote Panel, Local User Interface, or System Clock</i></p>	<p>Initiates a SPANHIGH-ACQUIRE mode at the beginning of the next integration period after the request was received. The ACQUIRE mode lasts for the averaging period. SPANHIGH will last for the number of integration periods equal to the difference between the periods for SPANHIGH variable and the periods for averaging variable. After the last period the TIE will indicate SPANHIGH mode and continue in that mode until another mode request is received.</p>	<p>The MIO goes into SPANHIGH-ACQUIRE mode after the TIE's first full integration period in SPANHIGH-ACQUIRE. The MIO will remain in this mode until the end of the TIE's first integration period in SPANHIGH. Any output configured to carry cal data will be updated with each reading as they occur. Those without cal will hold the last NORMAL reading during SPANHIGH-ACQUIRE and SPANHIGH. At each mode change the MIO will update its relay statuses to match the new mode. See timing diagram.</p>
--	--	--

Mode Change Request Table (continued)

Mode	TIE Function	Multi I/O (MIO) / Analog & Digital Output function
<p>SPANLOW <i>Initiated by: Digital Inputs, Enhanced Remote Panel, Local User Interface, or System Clock</i></p>	<p>Initiates a SPANLOW-ACQUIRE mode at the beginning of the next integration period after the request was received. The ACQUIRE mode lasts for the averaging period. SPANLOW mode will last for a given number of integration periods defined as the difference between the periods for SPANLOW variable and the periods for averaging variable. After the last period the TIE will indicate SPANLOW mode and continue in that mode until another mode request is received.</p>	<p>The MIO goes into SPANLOW-ACQUIRE mode after the TIE's first full integration period in SPANLOW-ACQUIRE. The MIO will remain in this mode until the end of the TIE's first integration period in SPANLOW. Any output configured to carry calibration data will be updated with each reading as they occur. Those without calibration data will hold the last NORMAL reading during SPANLOW-ACQUIRE and SPANLOW. At each mode change the MIO will update its relay statuses to match the new mode. See timing diagram.</p>
<p>ZERO <i>Initiated by: Digital Inputs, Enhanced Remote Panel, Local User Interface, or System Clock</i></p>	<p>Initiates a ZERO-ACQUIRE mode at the beginning of the next integration period after the request was received. The ACQUIRE mode lasts for the averaging period. ZERO mode will last for a given number of integration periods defined as the difference between the periods for ZERO variable and the periods for averaging variable. After the last period the TIE will indicate ZERO mode and continue in that mode until another mode request is received.</p>	<p>The MIO goes into ZERO-ACQUIRE mode after the TIE's first full integration period in ZERO-ACQUIRE. The MIO will remain in this mode until the end of the TIE's first integration period in ZERO. Any output configured to carry calibration data will be updated with each reading as they occur. Those without cal will hold the last normal reading during ZERO-ACQUIRE and ZERO. At each mode change the MIO will update its relay statuses to match the new mode. See timing diagram.</p>

ULTRAFLOW 150 GAS FLOW AND TEMPERATURE MONITOR

<p>CAL CYCLE Initiated by: Digital Inputs, Enhanced Remote Panel, Local User Interface, or System Clock</p>	<p>Initiates an internally timed calibration cycle consisting of the three CALIBRATION modes and their supporting ACQUIRE modes. The order is ZERO-ACQUIRE, ZERO, SPANLOW-ACQUIRE, SPANLOW, SPANHIGH-ACQUIRE and SPANHIGH. The combined length of each ACQUIRE/CAL mode is set by the number of periods for ZERO, SPANLOW, and SPANHIGH variables. If periods for ZERO are 10 and periods for AVERAGE are 6, the ZERO ACQUIRE mode will last for 6 integration periods and ZERO will last for 4 integration periods. To defeat any of the CAL modes set the number of periods for that mode equal to zero. See timing diagram.</p>	<p>The MIO mode follows the TIE mode. It changes modes when it sees that the TIE has been in the new mode for one full period. The MIO mode will be one integration period behind the TIE throughout the entire CAL CYCLE. The analog outputs will be updated at the end of each integration period. The relays will be updated at each MIO mode change. See timing diagram.</p>
<p>TEST ZERO SCALE Initiated by: Digital Inputs or Enhanced Remote Panel</p>	<p>The TIE ignores this mode request. The TIE will remain in whatever mode it was in. <i>This is an MIO test only.</i></p>	<p>The MIO enters this mode on receipt of the request. This mode will drive all analog outputs regardless of configuration to their ZERO scale. If actuated the NORMAL relay will drop out to indicate that other than NORMAL data is present on the outputs. The MIO will stay in this mode until another mode request is issued.</p>
<p>TEST MID SCALE Initiated by: Digital Inputs or Enhanced Remote Panel</p>	<p>The TIE ignores this mode request. It will remain in whatever mode it was in. <i>This is an MIO test only.</i></p>	<p>The MIO enters this mode on receipt of the request. This mode will drive all analog outputs regardless of configuration to their MID scale. If actuated the NORMAL relay will drop out to indicate that other than NORMAL data is present on the outputs. The MIO will stay in this mode until another mode request is issued.</p>
<p>TEST FULL SCALE Initiated by: Digital Inputs or Enhanced Remote Panel</p>	<p>The TIE ignores this mode request. It will remain in whatever mode it was in. <i>This is an MIO test only.</i></p>	<p>The MIO enters this mode on receipt of the request. This mode will drive all analog outputs regardless of configuration to their FULL scale. If actuated the NORMAL relay will drop out to indicate that other than NORMAL data is present on the outputs. The MIO will stay in this mode until another mode request is issued.</p>

Note: ACQUIRE modes are transitional modes designed to signal that the data from the monitor is in transition from one mode to another. For instance, ZERO ACQUIRE indicates that the monitor is producing data that is a mixture of ZERO and the previous mode. ACQUIRE modes last for the averaging period. This time can be determined by the following formula:

$$\text{AVERAGING PERIOD} = \text{Integration Periods in Average} * \text{Integration Period}$$

6.4.7 Output Module Configuration Menu

This sub-menu is password protected. It contains three screens for configuring the analog and digital outputs of the Multi I/O Board. The screens titled “ANALOG OUTPUTS 1,2” and “ANALOG OUTPUTS 3,4” configure their respective analog output parameter mapping and scaling. The “RELAY ASSIGNMENT” screen configures the conditions for closure of the eight output relays. Use the arrow keys to select OUTPUT MODULE CONFIG then press “↵”. This will prompt you to choose one of the three screens. Make your selection with the arrow keys and press enter.

Figure 6-6

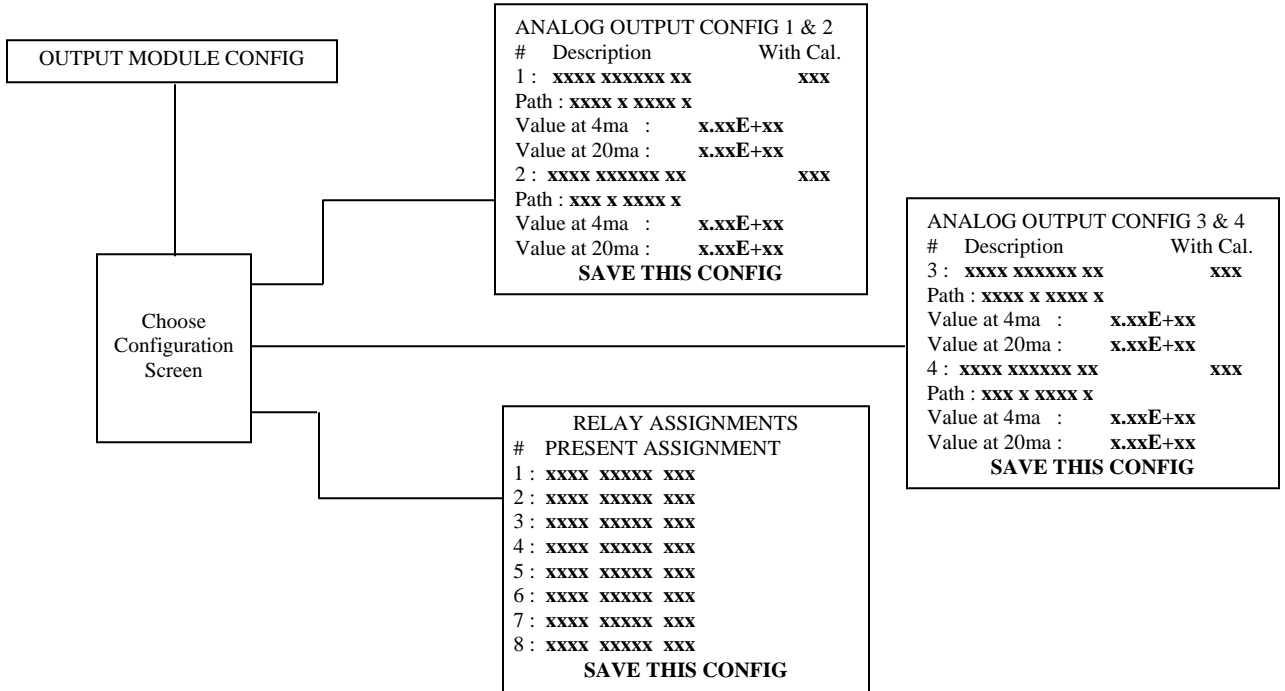

6.4.7.1 Analog Outputs 1,2

This screen is password protected. It configures the Multi I/O Board’s #1 & #2 analog outputs. It chooses:

- Parameter to be carried on the output
- Whether or not CAL values will be displayed on the output
- Numerical value at ZERO scale
- Numerical value at FULL scale

As described in previous sections, the physical properties of the outputs are configured with hardware jumpers on the Multi I/O Board. For a list of possible output parameters refer to Table 6-10, Parameters for Analog Output .

When this screen comes up, the parameter for display on output #1 will be highlighted. Use the “Page Up” and “Page Down” keys to find the parameter you want. Press “↓” to choose and move to the next property.

The WITH CAL field can be "YES", "NO" or "EXP". Use the "Page-up/Page-down" keys to find the parameter you want and press ENTER to select. The action of each selection is explained below.

WITH CAL = YES: Calibration data will be sent to that output when a calibration request is processed. Scaling for the calibration data will be the same as the Normal mode scaling entered under VALUE AT ZERO SCALE and VALUE AT FULL SCALE.

WITH CAL = NO: The output will not receive or display calibration values on it.

WITH CAL = EXP: Calibration data will be sent to that output when a calibration request is processed. Scaling for the SPANHIGH and SPANLOW calibration data will be the same as the Normal mode scaling entered under VALUE AT ZERO SCALE and VALUE AT FULL SCALE. However, scaling for ZERO calibration data will be $\pm 10\%$ of the VALUE AT FULL SCALE.

The next field chooses the TIE/path you want the output to look at. Again use "Page-up/Page-down" to find the path you want and press ENTER to select and move to the next field.

The field labeled VALUE AT ZERO SCALE: is the numerical value that will correspond to 4mA output. VALUE AT FULL SCALE: is the numerical value at full-scale (20mA) output. These values are what you would change to rescale the output if needed. Enter the numbers desired through the keypad. Press "↵" to move to the next field.

The second half of this screen offers the same options for Output #2. Make the desired choices in the same way or use the arrow keys to scroll to the "SAVE THIS CONFIG" line. If satisfied with the selections, press enter to save the selections you just made.

NOTE: *On this screen no changes are accepted by the Multi I/O configuration until the last field, SAVE THIS CONFIG, is entered. This field confirms that you want to implement the changes entered. If one of the fields is not correct use the ↑ or ↓ key to scroll to it. Once corrected move to "SAVE THIS CONFIG and press the enter "↵" key.*

6.4.7.2 Analog Outputs 3,4

This screen is password protected. The ANALOG OUTPUTS 3,4 menu screen functions exactly the same as the ANALOG OUTPUTS 1,2 menu screen. Only the output # references have changed. Refer to the Analog Outputs 1,2 section for a functional description.

6.4.7.3 Relay Assignments

This screen is password protected. This menu screen sets the condition for closure for each of the eight output relays on the Multi I/O Board. While the assignment for a particular relay is highlighted, scroll to the desired condition using the “Page-Up” and “Page Down” keys. Press “↵” to select. Move between the relays with the arrow or ENTER keys. Anytime a selection is changed ENTER must be pressed to confirm the selection. For a list of the possible selections see Table 6-9, Parameters for Relay Assignment.

NOTE: *On this screen no changes are accepted in the Multi I/O configuration until the last field, SAVE THIS CONFIG, has been selected and entered. This field confirms that you want to implement the changes entered. If one of the fields is not correct, use the ↑ or ↓ key to scroll to it. Once corrected, move to SAVE THIS CONFIG and press the “↵” key. The ESC key will take you back to the I/O configuration menu.*

6.4.8 Display Properties Menu

This screen permits adjustment of the Brightness and Contrast of the Display. Use the “↑” “↓” keys to select the parameter you want to adjust. Then use the “Page-up” and “Page-Down” keys to increase or decrease. The screen should visually change while pressing these keys. When the screen looks the way you want it, return to the main screen by pressing ESC.

An alternate method can be used to adjust the LCD display Contrast and back-light Brightness:

To increase display Contrast, press “Page-Up” and hold the “↑” key.

To decrease display Contrast, press “Page-Up” and hold the “↓” key.

To increase display back-light Brightness, press “Page-Down” and hold the “↑” key. To decrease display back-light Brightness, press “Page-Down” and hold the “↓” key.

6.4.9 Software Versions

This screen is not password protected.

6.4.10 System Properties Menu

This menu allows you to choose a group of TIE properties to view or alter. Monitor calibration is mainly accomplished through use of this group of screens.

The first selection under the System Properties Menu will permit setting of the number of TIE boxes in the system. You may move the “↓” key to highlight the “SELECT TIE:” option. You may toggle through the possible choices by using the “Page Up” or “Page Down” keys and then select the appropriate option using the “↵” key. The screens labeled “VIEW” are not password protected. Screens labeled “CHANGE” require either the Security Key or supervisor password to access. Use the “↑” & “↓” keys to select the screen and “↵” to enter. *Note that parameters are sent to the TIE as soon as the user hits “↵”. This is unlike the Output Module Configuration screens (see Analog Outputs 1,2 Section of this manual).*

A full explanation of the significance of all monitor parameters in the System Properties Menu is outside the scope of this manual. What follows is a concise explanation of the types of parameters in each group of properties and a flavor for their significance. Fundamental Properties are emphasized. Only one Advanced Properties screen is discussed as all the others are either troubleshooting in nature or require understanding outside the scope of this manual.

6.4.10.1 Fundamental Properties Menu

GEOMETRY PROPERTIES: Contains most stack geometry parameters with the exception of Cross Sectional Area.

CONTENTS: Downstream Nozzle Length
 Upstream Nozzle Length
 Transducer to Transducer
 Distance
 Offset

INTRINSIC PROPERTIES: Contains System Clock, Cross Sectional Area, Measurement Units, Transducer Type, Number of Measurement Paths (A or A and B) and other fundamental properties that apply to both measurement paths of a given TIE.

CONTENTS: System Clock
 Geometry Units (feet or meters)
 Measurement Paths (1=Path A;2 = Path A&B)
 Transducer Type
 Tone Bursts (typically 1)
 Flow Volume Units

The “Date” setting of the System Clock is accomplished by entering the data in the format: dd-mmm-yyyy. The selection for the month in the “mmm” format may be seen by using the “Page Up” or “Page Down” keys to display the

appropriate month abbreviation (Jan, Feb, Mar, etc.) After the proper month is displayed, the “↵” key will select the month and highlight the year. Enter the year information in the 4-digit format.

AVERAGING PROPERTIES: Sets response time. The monitor averages many transmit cycles in a boxcar integrator for a time period defined as the Integration Period. At the end of the period the contents of the boxcars are evaluated and a set of instantaneous values are declared. These instantaneous values are placed into a moving average filter from which an average value is derived. The user may set both the Integration Period (response time of the instantaneous data) and the Integration Periods in Average. Response time of the average data is the product of both parameters.

CONTENTS: Integration Period (seconds)
Integration Periods in Average
(dimensionless)

MEDIUM PROPERTIES: Contains the expected extremes of temperature and flow velocity in the stack or duct (medium) under measure.

CONTENTS: Minimum Medium Temperature
Maximum Medium Temperature
Minimum Flow Velocity
Maximum Flow Velocity

CALIBRATION PROPERTIES: Establishes set points and error tolerance for SPANHIGH, SPANLOW, and ZERO. Also establishes time of day and duration of the automatic calibration cycle. Note that IP is an acronym for Integration Period and that a phase of the automatic calibration cycle is disabled when set to zero.

CONTENTS: Span High Volume Set Point
Span Low Volume Set Point
Zero Volume Set Point
Calibration Tolerance (in volume, not %)
Hour of Auto Cal
Minute of Auto Cal
Calibration Interval Hour
IP Auto Cycle Span High
IP Auto Cycle Span Low (typ. = 0
[disabled]) IP Auto
Cycle Zero

FLOW CORR. CURVE PROPERTIES: This screen contains the flow velocity linearizer (correlation curve). The linearizer is a mathematical

equation applied to the actual flow velocity as derived from measured times of flight and the Geometry Properties parameters (see System Calibration and Adjustment, Section 8.0, for additional details). The linearizer is helpful for correcting for stratification, nonaxial flow or other effects. Either a polynomial (POLY) of order one to five or a three-point Look Up Table (LUT) may be used. The Flow Correlation Curve Source parameter selects which linearizer form is in use. Note that either the LUT or POLY must be enabled, i.e., the linearizer cannot be bypassed.

CONTENTS: X1,Y1,X2,Y2,X3,Y3 (LUT Points)
 A0,A1,A2,A3,A4,A5 (POLY Points)
 Flow Corr. Curve Source (POLY or LUT)

TEMP CALIBRATION PROPERTIES: This screen contains a three-point interpolation function meant to compensate the internal medium temperature channel for changes in the measurement medium gas properties. Speed of sound is used as the input or independent variable, therefore this compensation approach is only appropriate when the gas properties are a function of the speed of sound. “R Factors” are the desired outputs at the three speed of sound points. “R Factors” are directly proportional to the molecular weight of the medium and inversely proportional to heat capacity.

CONTENTS: R1,R2,R3 (“R Factor” Points)
 CS1,CS2,CS3 (Speed of Sound Points)

STD. PRESSURE PROPERTIES: This screen contains the two-point calibration curve for the optional external pressure transducer, the pressure to which the standardization is referenced and the parameter that enables or disables pressure correction. The Counts parameters are analog-to-digital converter values that correspond to the pressures at the two points.

CONTENTS: Standard Pressure Correction (ENABLE,
 DISABLE) Pressure at Point
 1
 Counts at Point 1
 Pressure at Point 2
 Counts at Point 2
 Reference Pressure

STD. TEMPERATURE PROPERTIES: This screen contains the two-point calibration curve for the optional external medium temperature transducer, the temperature to which the standardization is referenced and the parameter that enables or disables temperature correction. The Counts parameters are analog-to-digital converter values that correspond to the temperatures at the two points.

CONTENTS: Standard Pressure Correction (ENABLE,
 DISABLE) Temperature at
 Point 1

Counts at Point 1
 Temperature at Point 2
 Counts at Point 2
 Reference Temperature

ALARM PROPERTIES: This screen contains the alarm thresholds, actuating variable and operating mode of the flow volume and temperature alarms. The alarm mode and actuating variable selection apply to instantaneous and average alarms, but the thresholds are individually adjustable.

CONTENTS: Flow Alarm Selection
 Flow Alarm Mode
 Instantaneous Flow Alarm Threshold
 Average Flow Alarm Threshold
 Temperature Alarm Selection
 Temperature Alarm Mode
 Instantaneous Temperature Alarm Threshold
 Average Temperature Alarm Threshold

6.4.10.2 Advanced Properties Menu

Only one Advanced Properties screen, SN Ratio Alarms, is discussed as all others are troubleshooting in nature or require understanding outside the scope of this manual.

SN RATIO ALARMS: This screen contains the thresholds for the Signal-to-Noise (SN) Ratio Alarms. These alarms are useful for giving early warning of impending transducer failure. Some important points about these alarms are:

- ❑ Site specific alarm threshold values may be developed by recording SN Ratio data for the most challenging (typically highest flow velocity and temperature) measurement medium conditions, then setting the thresholds well below these levels. Typically a value of 1 is appropriate to most sites, but some applications may lower settings.
- ❑ The monitor measures instantaneous SN Ratio as a linear (not logarithmic or decibel) value.
- ❑ SN Ratio is calculated at the end of every Integration Period as an instantaneous number. There are no average values available.
- ❑ SN Ratio can be expected to vary substantially even during constant velocity and temperature conditions, especially when the ratio is high. Therefore, to avoid nuisance trips, it is better to set thresholds lower than higher.

CONTENTS: SN Ratio Threshold, Downstream
 SN Ratio Threshold, Upstream

6.4.11 View Trending Data

This menu screen selects the parameter trend to be displayed. Use the “↑” and “↓” keys to select the parameter you want to display then press “↵” to view that trend screen. ESC will take you back to the main menu.

Consult the Menu Tree diagram, Figure 6-2, of this section to find the menu/submenu location of individual screens.

6.4.12 View Numerical Data

There are four pages to the Numerical Data screen: One each for Flow, Internal Temperature, External Temperature & Pressure, and Network & MIO Status data. It is designed to be a place to simultaneously view all of the parameters for a given type of measurement, i.e., flow, internal temperature and so on. This is a good place to do a daily check of the monitor since all values are updated concurrently. If readings are taken from multiple screens, some differences in the readings may occur due to updates occurring while you are switching screens.

The NETWORK & MIO STATUS screen contains the Multi I/O Status word and several network event counters that keep a tally of the number of times each of the eight possible network errors occurs. These are specific errors defined by the network protocol. Each time one of the errors occurs at the Enhanced Remote Display node, an error message is issued and the network status log value for that error is incremented by one. These errors do not necessarily require corrective action but happen due to network contention issues that are a normal consequence of the network topology. A full description of these errors is beyond the scope of this manual. If necessary, please consult Teledyne Monitor Labs technical support for more information.

6.4.13 View Status History

This Screen has up to twelve pages depending on the number of system status changes that have taken place. It stores the previous 100 non-zero status word changes. Consecutive, identical non-zero status words cause only one entry. After one hundred entries the log is first in, first out. The most recent entries are at the top of the list on page one. Each entry consists of a code, the date, and time it occurred. Status words can be decoded as per the STATUS CODE HELP screen.

Consult the Menu Tree diagram, Figure 6-2, of this section to find the menu/submenu location of individual screens.

6.4.14 View Alarms History

The View Alarms History screen can have as many as twenty pages. The "Page-Up" and "Page-Down" keys move you to the next or previous page. This screen stores the previous 100 alarm events. An alarm event consists of setting or clearing any of the alarms that are defined in the SYSTEM PROPERTIES Menu. Each entry stores the parameter in alarm, type of alarm, date, time, and whether the event set or cleared the alarm. If an alarm event happens while viewing the screen, the information will scroll down and the new event will be posted at the top of page #1. After one hundred entries are recorded, the oldest one gets dropped from the log.

6.5 MULTI I/O SOFTWARE

6.5.1 ANALOG OUTPUTS

The four analog outputs of the Multi I/O Board can be configured to display any one of twenty-nine parameters. See Table 6-10, Parameters for Analog Output. Scaling for each of these four outputs is configurable and completely independent depending on the parameter selected. Both ZERO and FULL scale may be chosen for each output. Also each output may be configured to allow calibration cycles to appear on it.

The MIO has calibration values available in Flow Volume units and Velocity units. If an analog output is set to carry Flow Volume data and Calibration data is desired on that output, one of the Flow Volume calibration points must be chosen for the output. Likewise if an output is configured to carry Flow Velocity data one of the Flow Velocity calibration points must be chosen for the output. The system will allow any of the calibration points to be displayed with any parameter selection but if the units do not match, the scaling for the calibration parameter will be incorrect and the CAL data meaningless.

Five calibration options are available for output. They are selectable under the WITH CAL field of the analog output configuration screen.

The options are:

1. **WITH CAL = YES:** Calibration data will be sent to that output when a calibration request is processed. Scaling for the calibration data will be the same as the Normal mode scaling entered under VALUE AT ZERO SCALE and VALUE AT FULL SCALE.
2. **WITH CAL = NO:** The output will not receive or display calibration values on it.

3. **WITH CAL = EXP:** Calibration data will be sent to that output when a calibration request is processed. Scaling for the SPANHIGH and SPANLOW calibration data will be the same as the Normal mode scaling entered under VALUE AT ZERO SCALE and VALUE AT FULL SCALE. However, scaling for ZERO calibration data will be $\pm 10\%$ of the VALUE AT FULL SCALE.

6.5.2 DIGITAL INPUTS

The Multi I/O can issue mode change commands to the Transducer Interface Enclosure (TIE) based on the status of digital inputs one through six. These are known as the CAL REQUEST inputs. They can initiate the various calibration modes for each TIE. (*Both paths within a TIE follow the same mode change request.*) By controlling which input is activated, the operator can construct an “on-demand” calibration cycle to meet the systems needs. There are also inputs that will initiate the automatically timed internal CAL cycle for each TIE. See Table 6-7, Digital Inputs for Calibration Request.

The Multi I/O analog outputs can be forced to diagnostic status (TEST FULL SCALE, TEST ZERO SCALE, etc.) from two sources: digital inputs seven and eight, and the Enhanced Remote Display keypad. The operation of the digital inputs is described in Table 6-8, Digital Inputs for Analog Output Control. The keypad display commands are described in the section on menu structure. If the Multi I/O receives conflicting or overlapping requests for the analog outputs, its priority handler will assign requests from the digital inputs top priority and the keypad requests from the Enhanced Remote Display second priority.

6.5.3 DIGITAL OUTPUTS

The Multi I/O Board’s eight digital outputs (relays) can be configured to activate on any one of over eighty parameters. These are listed in Table 6-9, Parameters for Relay Assignment. They fall into three categories:

- ❑ Alarm indicators
- ❑ Fault indicators
- ❑ Output mode indicators

Standard practice is to assign a relay to each of the four CAL modes. These signals will then indicate when and what data is present on the analog outputs for data logging purposes. For more information on software function see the Operational Modes of the Transducer Interface Enclosure section (Section 4.0).

The digital output selections are self-explanatory except for the Data Valid, Fault, and Fatal Fault selections. Data is considered valid in all Multi I/O modes except TEST FULL SCALE, TEST MID SCALE, TEST ZERO SCALE, DIAGNOSTIC, and UNKNOWN when a Fatal Fault is not present. Fatal and Nonfatal Fault conditions are listed in Table 6-6, Fault Conditions. Fault conditions may also be gleaned from Figure 6-7, Relay Sequence & Timing.

Data Valid, Fault, and Fatal Fault are fail-safe in nature: they are energized during normal operation and de-energized when the appropriate condition arises.

Table 6-6**Fault Conditions**

FATAL FAULTS	NONFATAL FAULTS
SPAN LOW Calibration Failure	Signal Energy Ratio >3X
SPAN HIGH Calibration Failure	SN Ratio Warning, Upstream
ZERO Calibration bad	SN Ratio Warning, Downstream
SPAN LOW Offset TD bad	Purge Failure Upstream Side
SPAN HIGH Offset TD bad	Purge Failure Downstream Side
Minimum Signal Energy Not Achieved, Upstream	Noise Threshold Disabled
Minimum Signal Energy Not Achieved, Downstream	
Temperature Out of Range	
FPGA Config. Fault	
Out of Service	
Gain Disabled	
Boxcar Overflow	
Filter Mismatch	
3 X FPGA Timeout	
FPGA Timeout	
Divide By Zero	

Table 6-7**Digital Inputs for Calibration Request**

Input #1	Input #2	Input #3	Input #4	Input #5	Input #6	Command
0	0	0	0	0	0	No action results. No command request recognized.
1	0	0	0	0	0	SPAN HIGH TIE #1
0	1	0	0	0	0	ZERO TIE #1
1	1	0	0	0	0	SPAN LOW TIE #1
0	0	1	0	0	0	CAL CYCLE TIE #1
0	0	0	1	0	0	SPAN HIGH TIE #2
0	0	0	0	1	0	ZERO TIE #2
0	0	0	1	1	0	SPAN LOW TIE #2
0	0	0	0	0	1	CAL CYCLE TIE #2

All other combinations of Inputs #1 through #6.	No action results. These are considered invalid command requests.
---	---

Note: In the above table, a “1” designates actuation of an Isolator Input and “0” designates de-actuation.

Table 6-8
Digital Inputs for Analog Output Control

Input #7	Input #8	Command
0	0	No action results. No command request recognized.
1	0	TEST ZERO SCALE
0	1	TEST FULL SCALE
1	1	TEST MID SCALE

Note: In the above table, a “1” designates actuation of an Isolator Input and “0” designates de-actuation.

Table 6-9
Parameters for Relay Assignment
(Digital Output Closure Conditions)

Alarm Indicators TIE #1	Alarm Indicators TIE #2	Output Mode Indicators TIE #1	Output Mode Indicators TIE #2	Fault Indicators TIE #1	Fault Indicators TIE #1
INST VOLUME ALARM TIE1	INST VOLUME ALARM TIE2	SPAN HIGH ON AO TIE1	SPAN HIGH ON AO TIE2	DATA VALID TIE1A	DATA VALID TIE2A
AVG VOLUME ALARM TIE1	AVG VOLUME ALARM TIE2	SPAN LOW ON AO TIE1	SPAN LOW ON AO TIE2	NONFATAL FAULT TIE1A	NONFATAL FAULT TIE2A
INST MED TEMP ALARM TIE1	INST MED TEMP ALARM TIE2	ZERO ON AO TIE1	ZERO ON AO TIE2	FATAL FAULT TIE1A	FATAL FAULT TIE2A
AVG MED TEMP ALARM TIE1	AVG MED TEMP ALARM TIE2	NORMAL ON AO TIE1	NORMAL ON AO TIE2	PURGE FAILURE TIE1A	PURGE FAILURE TIE2A
SN RATIO UP ALARM TIE1A	SN RATIO UP ALARM TIE2A	CAL ON AO TIE1	CAL ON AO TIE2	CAL FAILURE TIE1A	CAL FAILURE TIE2A
SN RATIO DN ALARM TIE1A	SN RATIO DN ALARM TIE2A	INTERFERENCE TEST TIE1A	INTERFERENCE TEST TIE2A	DATA VALID TIE1B	DATA VALID TIE2B
SN RATIO BOTH ALARM TIE1A	SN RATIO BOTH ALARM TIE2A	INTERFERENCE TEST TIE1B	INTERFERENCE TEST TIE2B	NONFATAL FAULT TIE1B	NONFATAL FAULT TIE2B
SN RATIO UP ALARM TIE1B	SN RATIO UP ALARM TIE2B	INTERFERENCE TEST TIE1AorB	INTERFERENCE TEST TIE2AorB	FATAL FAULT TIE1B	FATAL FAULT TIE2B

SECTION 6.0, ENHANCED REMOTE PANEL W/MULTI I/O MODULE

SN RATIO DN ALARM TIE1B	SN RATIO DN ALARM TIE1B	SPAN HIGHorACQ ON AO TIE1	SPAN HIGHorACQ ON AO TIE2	PURGE FAILURE TIE1B	PURGE FAILURE TIE2B
SN RATIO BOTH ALARM TIE1B	SN RATIO BOTH ALARM TIE2B	SPAN LOWorACQ ON AO TIE1	SPAN LOWorACQ ON AO TIE2	CAL FAILURE TIE1B	CAL FAILURE TIE2B
SN RATIO UP ALARM TIE1AorB	SN RATIO UP ALARM TIE2AorB	ZERO OR ACQ ON AO TIE1	ZERO OR ACQ ON AO TIE2	DATA VALID TIE1AorB	DATA VALID TIE2AorB
SN RATIO DN ALARM TIE1AorB	SN RATIO DN ALARM TIE2AorB	NORMAL OR ACQ ON AO TIE1	NORMAL OR ACQ ON AO TIE2	NONFATAL FAULT TIE1AorB	NONFATAL FAULT TIE2AorB
SN RATIO BOTH ALARM T1AorB	SN RATIO BOTH ALARM T2AorB	CAL OR ACQ ON AO TIE1	CAL OR ACQ ON AO TIE2	FATAL FAULT TIE1AorB	FATAL FAULT TIE2AorB
				PURGE FAILURE TIE1AorB	PURGE FAILURE TIE2AorB
"NO SELECTION" IS ALSO AN OPTION				CAL FAILURE TIE1AorB	CAL FAILURE TIE2AorB

Table 6-10
Parameters for Analog Output

NOTE: Each of the parameters for output can carry data from either TIE and either path or the average of the two paths. The TIE and path are selected on the output configuration screen.

Parameter Name	Functional Description
INSTANT VELOCITY	This parameter is the linearized, instantaneous, actual velocity as measured during a single integration period. It is linearized per the curve developed from site testing
AVE VELOCITY	This parameter is an average of the linearized, instantaneous velocity values from a number of integration periods. The number of periods is set by the “periods for averaging” variable. The length of the averaging period will be “seconds of integration” X “number of periods averaged”.
INSTANT RAW VELOCITY	This parameter is the raw, unlinearized, instantaneous, actual velocity as measured during a single integration period.
AVE RAW VELOCITY	This parameter is an average of the raw unlinearized instantaneous velocity values from a number of integration periods. The number of periods is set by the “periods for averaging” variable. The length of the averaging period will be “seconds of integration” X “number of periods averaged”.
INSTANT ACT VOLUME	This parameter is the linearized, instantaneous, actual volume as measured during a single integration period. It is linearized per the curve developed from site testing .
AVE ACT VOLUME	This parameter is an average of the linearized, instantaneous actual volume values from a number of integration periods. The number of periods is set by the “periods for averaging” variable. The length of the averaging period will be “seconds of integration” X “number of periods averaged”.
INSTANT STD VOLUME	This parameter is the linearized, instantaneous, standard volume as measured during a single integration period. It is linearized per the curve developed from site testing and corrected to standard temperature and/or pressure conditions.
AVE STD VOLUME	This parameter is an average of the linearized, instantaneous standard volume values from a number of integration periods. The number of periods is set by the “periods for averaging” variable. The length of the averaging period will be “seconds of integration” X “number of periods averaged”.
INST MEDIUM INT TEMP	This parameter is the instantaneous temperature of the medium as measured by the monitor during a single integration period.
AVE MEDIUM INT TEMP	This parameter is an average of the instantaneous temperature of the medium as measured by the monitor during a number of integration periods. The number of periods is set by the “periods for averaging” variable. The length of the averaging period will be “seconds of integration” X “number of periods averaged”.
INSTANT SOUND SPEED	This parameter is the instantaneous speed of sound through the medium as measured by the monitor during a single Integration Period.
AVG SOUND SPEED	This parameter is an average of the instantaneous speed of sound values as measured by the monitor during a number of Integration Periods. The number of periods is set by the “periods for averaging” variable. The length of the averaging period will be “seconds of integration” X “number of periods averaged”.
AVG SPAN HIGH	This parameter is an average of the instantaneous span high values as measured by the monitor during a number of Integration Periods. The number of periods is set by the “periods for averaging” variable. The length of the averaging period will be “seconds of integration” X “number of periods averaged”.
AVG SPAN LOW	This parameter is an average of the instantaneous span low values as measured by the monitor during a number of Integration Periods. The number of periods is set by the “periods for averaging” variable. The length of the averaging period will be “seconds of integration” X “number of periods averaged”.

Parameters for Analog Output (continued)

Parameter Name	Functional Description
AVG ZERO	This parameter is an average of the instantaneous zero values as measured by the monitor during a number of Integration Periods. The number of periods is set by the “periods for averaging” variable. The length of the averaging period will be “seconds of integration” X “number of periods averaged”.
sSN RATIO UPSTREAM	This parameter is a number between 0 and 1000 which represents the signal to noise ratio of the upstream transducer on the TIE/path selected. See note **
SN RATIO DOWNSTREAM	This parameter is a number between 0 and 1000 which represents the signal to noise ratio of the downstream transducer on the TIE/path selected. See note **
DIGITAL GAIN UPSTREAM	This parameter is a number between 0 and 255, which represents the digital gain applied to the upstream receive signal on the Mother Board of the TIE/path selected. See note **
DIGITAL GAIN DNSTREAM	This parameter is a number between 0 and 255, which represents the digital gain applied to the downstream receive signal on the Mother Board of the TIE/path selected. See note **
PREAMP GAIN UPSTREAM	This parameter is a number between 0 and 4095, which represents the gain applied to the upstream preamp receive signal of the TIE/path selected. See note **
PREAMP GAIN DNSTREAM	This parameter is a number between 0 and 4095, which represents the gain applied to the downstream preamp receive signal of the TIE/path selected. See note **
PEAK RAM CNTS UPSTREAM	This is a number between 0 and 32,767 which represents the upstream box car RAM count with the single largest value as measured at the end of each Integration Period of the TIE/path selected. See note **
PEAK RAM CNTS DNSTREAM	This is a number between 0 and 32,767 which represents the downstream box car RAM count with the single largest value as measured at the end of each Integration Period of the TIE/path selected. See note **
CALC RAM CNTS UPSTREAM	This is a number between 0 and 32,767 which represents the peak RAM count of the upstream receive signal box car as calculated by the signal processing algorithms at the end of the Integration Period of the TIE/path selected. See note **
CALC RAM CNTS DNSTREAM	This is a number between 0 and 32,767 which represents the peak RAM count of the downstream receive signal box car as calculated by the signal processing algorithms at the end of the Integration Period of the TIE/path selected. See note **
INST MEDIUM EXT TEMP	This parameter is the instantaneous temperature of the medium as measured by the external temperature device during a single Integration Period.
AVE MEDIUM EXT TEMP	This parameter is an average of the instantaneous temperature of the medium as measured by the external temperature device during a number of Integration Periods. The number of periods is set by the “periods for averaging” variable. The length of the averaging period will be “seconds of integration” X “number of periods averaged”.
INST MEDIUM PRESSURE	This parameter is the instantaneous barometric pressure as measured by the external pressure device.
AVE MEDIUM PRESSURE	This parameter is an average of the instantaneous barometric pressure as measured by the external pressure device during a number of Integration Periods. The number of periods is set by the “periods for averaging” variable. The length of the averaging period will be “seconds of integration” X “number of periods averaged”.

** If an SN RATIO, GAIN, or RAM CNT parameter is selected and configured to carry “path =both” data, the data will default to path A data since the average of this path A&B data is meaningless.

Figure 6-7 Relay Sequence & Timing

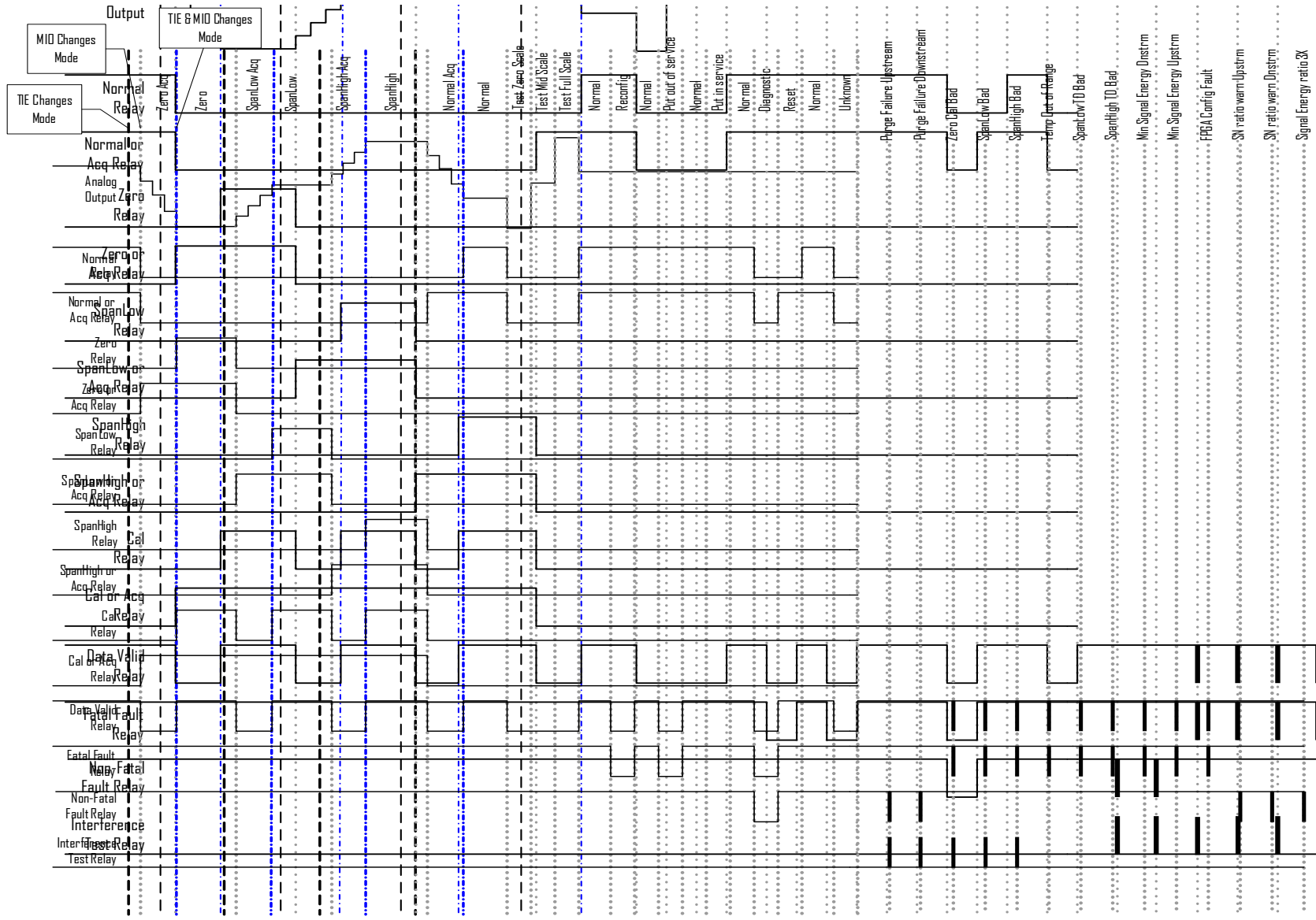

7.0 INSTALLATION

The installation overview of the Ultraflow 150 system is shown in Drawings ULTRAFLOW 150 FLANGE INSTALLATION, and ULTRAFLOW 150 SYSTEM INSTALLATION. It is important that the centerline of the two transducers be maintained so that the installed transducers can be pointed directly at each other.

7.1 PRE-INSTALLATION PLANNING AND PREPARATION

The engineering that precedes installation of the Ultraflow 150 is vital to successful operation of the instrument and must be performed in consultation with responsible Teledyne Monitor Labs representatives. Key factors that must be considered include:

Location of the Purge Nozzle and Mounting Plate Assembly, and Transducer Interface Enclosure (TIE). Items such as vibration, heat range, stream turbulence, installation and maintenance access, and protection from environmental and mechanical hazards must be considered.

Proper installation and location of the Purge Assembly (as per installation drawing).

Electrical power source, cable and conduit runs, overload protection, and provisions for safety disconnect.

Signal cable run (distance, routing, and proximity to other electrical equipment).

Location of the Enhanced Remote Panel. Auxiliary circuits such as alarms, auxiliary indicator/displays, etc., must be considered.

An installation packet containing a number of Teledyne Monitor Labs drawings and a document titled, "Ultraflow 150 Installation Guide & Checklist", is provided to the user soon after the purchase order for the equipment is received by Teledyne Monitor Labs. The mounting plates, which are supplied by Teledyne Monitor Labs as part of the system, may be shipped at the same time if requested by the customer. The installation checklist contains a number of questions that must be answered by the user before assembly and calibration of the system may begin at the Teledyne Monitor Labs factory.

7.2 SITE SELECTION

Without question, the single most important factor affecting overall performance of any continuous monitoring device is that of site selection. If this decision is not made prudently, then monitor accuracy and reliability will suffer.

7.2.1 Representative Sampling Location

Since the Ultraflow 150 uses an "across stack", non-contacting sampling technique, it measures the average flow velocity along a path from one transducer to another, which passes through the center of the stack or duct. Although this technique is inherently more representative than point sampling schemes, complex flow patterns in the vicinity of bends or obstructions may potentially cause the monitor's sample path to be unrepresentative of the total flow velocity and volume. Teledyne Monitor Labs Installation Drawing ULTRAFLOW 150 FLANGE INSTALLATION contains minimum recommended location distances from upstream and downstream bends, which should allow for proper sampling. However, due to the complexity of the fluid dynamics of these types of gas streams and their dependence on individual site geometry, the burden of responsibility for testing to determine the flow characteristics at the site location is solely that of the user. Please consult the Teledyne Monitor Labs factory for details.

7.2.2 Access to Sampling Location

Ease of access to the stack mounted equipment is a factor that is nearly always underrated when deciding on an installation site. If the monitor location is only accessible via vertical ladders with extensive climbing involved or in exposed outside areas where maintenance personnel are subject to extremes of wind, precipitation, or temperature, then monitor maintenance will suffer adversely in the long term. Without proper maintenance, reliability decreases and the access problems extend monitor outage during repair.

7.2.3 Environmental Conditions at the Sampling Location

The other important factor involved in site selection is to consider the potential conditions of the area where the Transducer Interface Enclosure and Purge System will be located. Ambient conditions at this location must not exceed the temperature range specified in the Teledyne Monitor Labs specifications. This will void the Teledyne Monitor Labs warranty.

The presence of potentially corrosive or toxic gases in the ambient air in the vicinity of the Transducer Interface Enclosure and Purge Air System may deteriorate the condition of electrical connections such as IC sockets, connectors, etc., in the electronic assembly. This may also greatly reduce

the expected life of the purge motor by causing early bearing failure. The hazards and limitations placed on service personnel would also reduce the basic reliability of the monitoring system.

7.3 EQUIPMENT MOUNTING CONSIDERATIONS

7.3.1 Flange and Mounting Tube Installation

Installation of the Teledyne Monitor Labs supplied mounting flange and the user supplied mounting tube is the responsibility of the user. Consult Teledyne Monitor Labs Drawing ULTRAFLOW 150 FLANGE INSTALLATION for details. Care must be taken in reporting the information requested by Teledyne Monitor Labs in the “Ultraflow 150 Installation Guide & Checklist”. This will ensure that sufficient clearances exist to install and remove the Purge Nozzle Assemblies, which house the transducers.

Additionally a Mounting Plate Alignment Tool may be purchased to help maintain acceptable alignment tolerances between the two mounting tubes during installation of the flange and mounting tubes. Installation of the mounting tubes is best accomplished by first assembling the mounting plate and mounting tube as a single unit in a welding shop where adequate care can be taken to see that the plate and tube are square with one another. Information on the diameter, length, and angle of the mounting tubes is given on ULTRAFLOW 150 FLANGE INSTALLATION drawing. This drawing also contains a number of calculations that must be performed in order to accurately determine the angle and size of the penetrations into the stack or duct. The actual penetrations should be made with some additional clearance so that the prefabricated mounting tube and plate may be inserted as a unit and temporarily held in place. Insert one mounting tube first and secure it in place temporarily. Then install the Mounting Plate Alignment Tool on the mounting plate. Illuminate the opening on the opposite side of the stack so that it may be seen through the alignment scope. Then shim or move the mounting tube until the cross hair of the alignment scope falls in the center of the opening on the opposite side of the stack. Temporarily secure this tube in place with a tack weld or other means and then insert the other mounting tube and plate assembly. Using the same procedures as just mentioned, install the alignment scope on the second mounting tube and shim in place when the alignment is correct. After both sides have been checked and require no additional adjustments, secure both assemblies permanently using grout, welds or other means appropriate to the particular construction.

On short path length installations (diagonal distances less than 25 feet) mounting tube misalignment is not generally a critical problem because the transmitted ultrasonic tone burst is relatively omni directional. As the path length increases, the issue of signal strength becomes more

problematic. However, the use of the alignment scope can certainly provide alignments of less than 1 degree. This is more than adequate for such installations.

7.3.2 Purge System, Reference PURGE ASS'Y MTG., PLUMBING & CLEARANCE REQUIREMENTS Drawing

Location of the Purge System must be undertaken giving consideration to the environmental conditions at the sampling location covered in a previous sub-section of Section 7.0.

NOTE: *It is imperative that the circuit supplying power to the purge system be one that is never ordinarily interrupted while the stack is in operation.*

The transducer elements of the system will ordinarily survive for only a very short period of time without the purge air in operation. Hot corrosive combustion gases may contaminate or damage the ultrasonic transducers without the protective Purge Air System. Consult Teledyne Monitor Labs Drawings ULTRAFLOW 150 STANDARD WIRING DIAGRAM and ULTRAFLOW 150 SYSTEM INSTALLATION for power and location specifications.

CAUTION: *During initial start-up, the purge system must be in full operating condition and the hoses supplying the purge air connected before the Purge Nozzle Assemblies are inserted into the mounting tubes. Failure to do so will void the Teledyne Monitor Labs warranty on the stack equipment.*

7.3.3 Purge Nozzle and Mounting Flange Assembly, Reference PURGE NOZZLE AND MTG. PLATE INSTALLATION-150 Drawing.

The actual length of the Purge Nozzle and Mounting Flange Assembly is determined by Teledyne Monitor Labs from information supplied by the user in the "Ultraflow 150 Installation Guide & Checklist". This length is unique to an individual installation as a result of variations in the thickness and construction of different stacks or ducts. Since the angle at which the mounting tubes and purge nozzles are mounted may also vary, each Purge Nozzle Assembly is fabricated so that when properly installed the actual transducer element is located precisely where the inside diameter of the stack meets the center of the mounting tube.

CAUTION: *The Purge Air System must be in full operation and properly connected to the Purge Nozzle Assemblies anytime they are inserted into the mounting tube and prepared for alignment.*

Install the Purge Nozzle Assemblies into the seals and assemble the hardware loosely until it is certain that all pieces have been properly fabricated. Reference the Teledyne Monitor Labs Drawing PURGE NOZZLE AND MTG. PLATE INSTALLATION-150, to see how the flange, seal, squeeze ring, threaded rods, etc. are configured. Take extra precautions to see that the purge holes described on this drawing are inside of the seal when the assemblies are completely installed. Otherwise the transducers and mounting tubes will not receive the full benefit of the purge air and the stack effluent may damage the transducers. When properly installed the transducer element will be located at the inside wall of the stack and the purge holes in the nozzle assemblies will fall inside of the seal.

Adjustment of the nozzle depth and directional alignment of the assemblies is accomplished by using the four 1/2-13 stainless steel threaded rods and nuts. Once proper alignment is achieved, the 1/2 inch nuts should be locked in place. Removal of the nozzle for maintenance is accomplished by undoing the four draw latches. Use of the draw latches insures proper alignment when nozzles are reinserted.

7.3.4 Transducer Interface Enclosure Assembly, Reference XDUCER INTERFACE ENCLOSURE INSTALLATION Drawing

Location and clearance requirements for the Transducer Interface Enclosure Assembly are found in Teledyne Monitor Labs Drawings ULTRAFLOW 150 SYSTEM INSTALLATION, XDUCER INTERFACE ENCLOSURE INSTALLATION, and XDUCER INTERFACE ENCLOSURE INTERNAL LAYOUT. Since the Transducer Interface Enclosure contains a Microprocessor to control its operation, some consideration may be given to its location in respect to large AC motors or other potential sources of radiated EMI.

Before applying power to the Transducer Interface Enclosure be certain that all electrical connections have been made to the stack equipment. Refer to Teledyne Monitor Labs Drawing ULTRAFLOW 150 STD. WIRING DIAGRAM.

7.3.5 Junction Box, Reference JUNCTION BOX MTG. METHODS AND CLEARANCES Drawing

Installation information and clearance requirements can also be found in Teledyne Monitor Labs Drawing ULTRA FLOW 150 SYSTEM INSTALLATION.

7.3.6 Enhanced Remote Panel Assembly, Reference ENHANCED REMOTE PANEL ASSEMBLY Drawing

Consideration should be given to the ability of the operators or interested personnel to view the displays or output devices readily. Access to the panel by installation and maintenance personnel must also be provided for. Reference Teledyne Monitor Labs Drawing ENHANCED REMOTE PANEL ASSEMBLY for mounting dimensions. Reference Teledyne Monitor Labs Drawing ULTRAFLOW 150 STD. WIRING DIAGRAM for proper electrical connections to the Enhanced Remote Panel Assembly.

(This page intentionally left blank.)

8.0 SYSTEM CALIBRATION AND ADJUSTMENT

The calibration of the Ultraflow 150 system at the Teledyne Monitor Labs factory consists primarily of configuring the Transducer Interface Enclosure (TIE) and Enhanced Remote Panel (ERP) variables to accurately represent the actual physical dimensions at the user's site. The relationship between these physical dimensions and the program variables will determine the output of the analyzer. These dimensions are received from the user on a document titled "Ultraflow 150 Installation Guide & Checklist". The checklist is provided to each user very soon after the purchase order for the system is received by Teledyne Monitor Labs, and describes the information required to properly model the user's installation site. The initial accuracy of the analyzer is dependent on the reliability of the information provided by the user.

Most site specific program variables used to configure the system are held in memory by a battery backed up RAM, while some are stored in Flash memory. This allows the variables to be field modified and remain in the microprocessor after the power is turned off. It may be necessary to modify some variables at the users site at the time of instrument start up or after reference method testing.

NOTE: *The user must maintain adequate documentation on any variables modified after factory calibration. In the event of any failure of the EPROMs or RAM battery, this documentation may be the only source of these variable values. Teledyne Monitor Labs recommends that Appendix A of this manual be used to record any such changes.*

8.1 TRANSDUCER INTERFACE ENCLOSURE CALIBRATION

8.1.1 Transducer Interface Enclosure Program Variables

Certain TIE program variables are responsible for the actual accuracy of the analyzer and have a direct affect on the system calibration. These variables can be entered through the ERP Keypad. Reference manual section on ERP (Section 6.0) for instructions on how to access the variables listed.

Geometry Properties:

- Downstream Nozzle length.
- Upstream Nozzle length
- Transducer to Transducer Distance
- Offset

Intrinsic Properties:

- Cross Sectional Area
- Geometry Units
- Measurement Paths

ULTRAFLOW 150 GAS FLOW AND TEMPERATURE MONITOR

- Transducer Types
- Tone Bursts per Transmit
- Flow Volume Units

Averaging Properties:

- Integration Period Seconds
- Integration Periods in Average

Medium Properties:

- Minimum Medium Temperature
- Maximum Medium Temperature
- Minimum Flow Velocity
- Maximum Flow Velocity

Calibration Properties:

- Span High Volume Set Point
- Span Low Volume Set Point
- Zero Volume Set Point
- Calibration Tolerance
- Hour of Auto Calibration
- Minute of Auto Calibration
- Calibration Interval Hour
- Integration Periods in Auto Cycle Span High
- Integration Periods in Auto Cycle Span Low
- Integration Periods in Auto Cycle Zero

Typically, for maximum accuracy in Continuous Emission Monitoring Systems (CEMS), the Ultraflow 150 is field calibrated versus a multipoint pitot tube flow measurement done according to US EPA Reference Method 40CFR60 Appendix A Methods 1 and 2 (extractive test). While the ultrasonic time of flight method is among the best methods for flow measurement in difficult applications, there are situations where its response is not perfectly linear and does not exactly match the Reference Method. Flow stratification and cross-flow, i.e., nonzero pitch angles, are the most common sources of departure from linearity. Also, the aforementioned Reference Methods 1 and 2 can be significant sources of error themselves.

The flow velocity channel of the Ultraflow150 supports two approaches to “linearize” the instrument to compensate for these effects: 1) Look Up Table (LUT) and Polynomial (POLY). The user must select one of these two approaches via the “Correlation Curve Source” variable. Both approaches apply the linearizer curve to the actual flow velocity as derived directly from the time of flights (“Raw” Actual Velocity) in feet/second (or meters/second if units are in metric).

NOTE: *It is very important to use actual flow velocity in the indicated units since these are nonlinear functions. If volume units are used in the generation process, the linearizer curve will be in a totally different numerical region and the behavior will not be as anticipated.*

SECTION 8.0, SYSTEM CALIBRATION AND ADJUSTMENT

Flow Correction Curve Properties:

- Look Up Table (LUT):
 - X1
 - Y1
 - X2
 - Y2
 - X3
 - Y3
- Polynomial (POLY):
 - A0
 - A1
 - A2
 - A3
 - A4
 - A5

Table 8-1

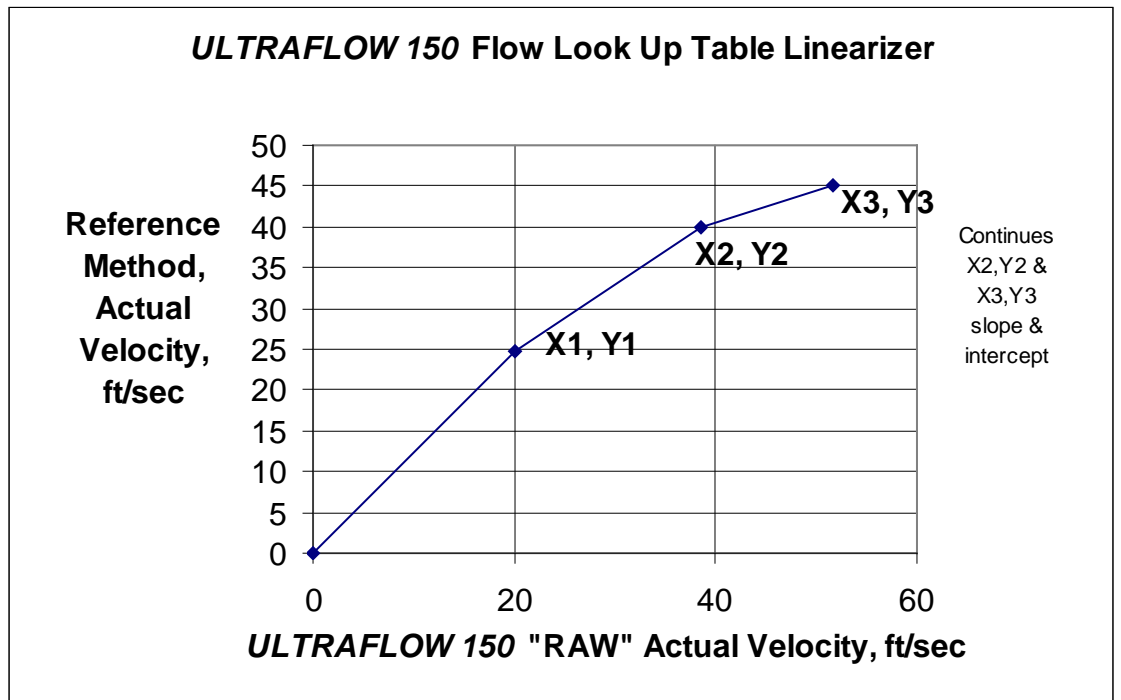

The points for the Look Up Table must be derived through reference method testing. Each point consists of an Ultraflow 150 value (X) and an associated reference method test value (Y). The Ultraflow value is then derived as a straight-line approximation, using up to three line segments. The first segment has zero as its origin and ends at the first Ultraflow/reference method pair of numbers entered. The second segment is a line from the first number pair (X1, Y1) to the second Ultraflow/reference method pair of numbers (X2, Y2). The third segment

runs from the second number pair (X2, Y2) to the third Ultraflow/reference method pair of numbers (X3, Y3). If a segment is not used, "-1" is entered for the terminal point Ultraflow value. Thus if "-1" is entered for the last Ultraflow point only two lines are used for the curve fit. If the second and third Ultraflow points are "-1", only one line is calculated. If all three points are "-1", Look Up calculations are disabled.

Table 8-2

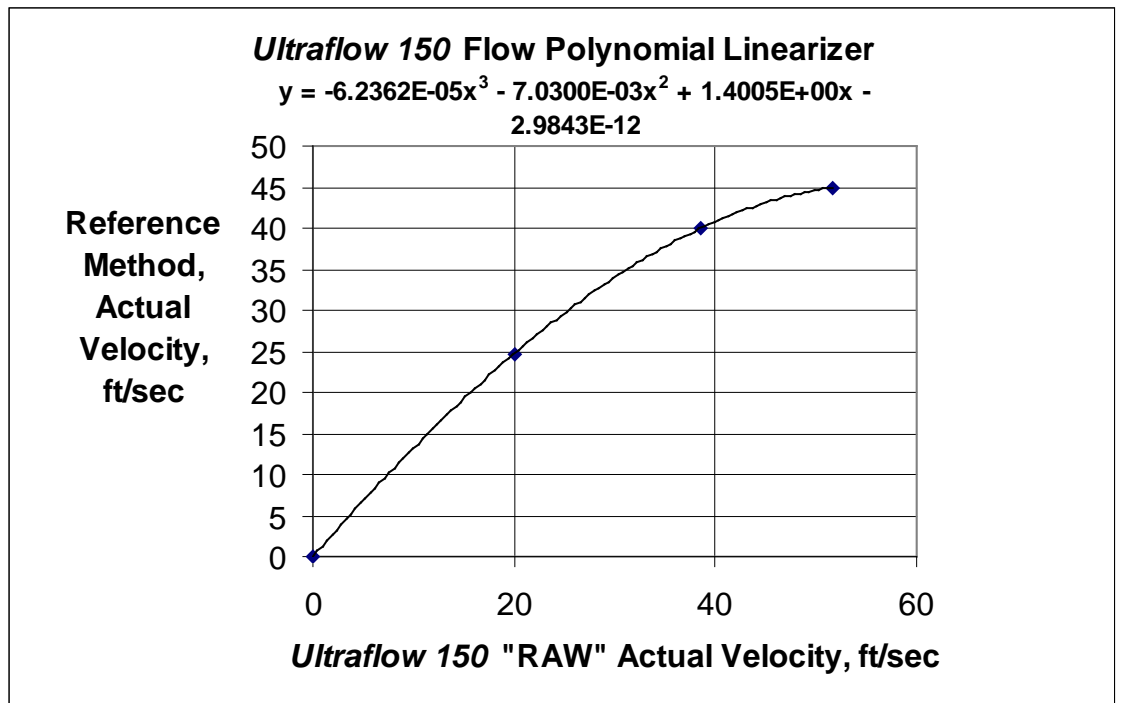

The Polynomial A0 through A5 contain the coefficients of a 5th order Polynomial least squares correction curve fit, which may be employed to modify the velocity output of the Ultraflow 150 to more closely correlate with the reference method testing data over differing load conditions. Teledyne Monitor Labs must be consulted in order to properly employ this curve because the mathematical programs used to determine these coefficients must be evaluated subjectively for anomalies. In analyzers not employing such correction devices A1 = 1. A0, A2, A3, A4, and A5 will be equal to zero.

Temperature Calibration Properties:

- R-factor 1 (R1)
- Speed of Sound 1 (C_{s1})
- R-factor 2 (R2)
- Speed of Sound 2 (C_{s2})
- R-factor 3 (R3)
- Speed of Sound 3 (C_{s3})

Table 8-3

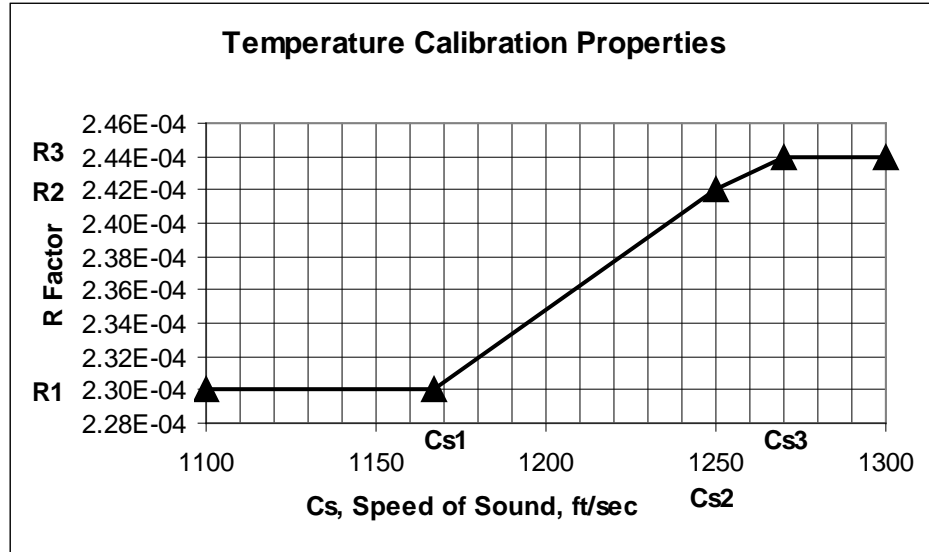

The Ultraflow 150 measures temperature via time of flight of sound (Internal Medium Temperature) or by use of an external temperature sensor. The Internal Medium Temperature measurement is affected by the molecular weight and heat capacity of the medium.

When these medium properties are function of the speed of sound (typical of single fuel stack gases from combustion processes), it is possible to adjust the temperature calibration with a Look Up Table (LUT) correction. The above figure demonstrates the relationship between R Factor and speed of sound (C_s) for the LUT.

Three breakpoints are provided: (1) R1, C_{s1} ; (2) R2, C_{s2} ; and (3) R3, C_{s3} . Typically R1 is set for ambient air medium properties and C_{s1} is set to the value of speed of sound at some point above typical room temperature values.

In utility boiler applications, the upper two points are set for the medium properties (R2, R3) and speeds of sound (C_{s2} , C_{s3}) at mid and high loads. R2, C_{s2} is typically set at mid load and R3, C_{s3} at high load. Breakpoint (2) C_{s2} , R2 can be disabled by entering “-1” in C_{s2} . Breakpoints (1) and

(3) must always be used. See Section 6, Temp. Calibration Properties, for additional details.

Standard Pressure Properties:

- Standard Pressure Correction: ENABLE/DISABLE
- Pressure at Point 1
- Current at Point 1
- Pressure at Point 2
- Current at Point 2
- Reference Pressure

Standard Temperature Properties:

- Temperature Source: INTERNAL/EXTERNAL
- Standard Temperature Corr: ENABLE/DISABLE
- Temperature at Point 1
- Current at Point 1
- Temperature at Point 2
- Current at Point 2
- Reference Temperature

Alarm Properties:

- | | |
|----------------|--|
| A | <ul style="list-style-type: none"> ▪ Flow Alarm Selection: Actual Volume A
Standard Volume |
| B | <ul style="list-style-type: none"> ▪ Flow Alarm Selection: Actual Volume B
Standard Volume |
| AB | <ul style="list-style-type: none"> ▪ Flow Alarm Selection: Actual Volume |
| AB | <ul style="list-style-type: none"> ▪ Flow Alarm Selection: Standard Volume |
| Temperature B | <ul style="list-style-type: none"> ▪ Flow Alarm Mode: LESSER/GREATER ▪ Instantaneous Flow Alarm Threshold ▪ Average Flow Alarm Threshold ▪ Temp. Alarm Selection: Internal
Temperature A |
| Temperature AB | <ul style="list-style-type: none"> ▪ Temp. Alarm Selection: Internal |
| Temperature | <ul style="list-style-type: none"> ▪ Temp. Alarm Selection: Internal ▪ Temp. Alarm Mode: LESSER/GREATER ▪ Instantaneous Flow Alarm Threshold ▪ Average Flow Alarm Threshold |

Resolution Properties:

- Time Between Transmits
- Seconds per TD
- Second per RAM Count

Gain Limits:

- Minimum Analog Gain
- Maximum Analog Gain

SECTION 8.0, SYSTEM CALIBRATION AND ADJUSTMENT

- Minimum Digital Gain
- Maximum Digital Gain

Gain Values:

- Auto Gain Control: ENABLE/DISABLE
- Preamp Gain Downstream
- Preamp Gain Upstream
- Digital Gain Downstream
- Digital Gain Upstream

Time Delays:

- Time Delay Downstream A
- Time Delay Upstream A
- Intrinsic Delay A
- Nozzle Delay Downstream A
- Nozzle Delay Upstream A

Noise Threshold Levels:

- Auto Noise Threshold A: ENABLE/DISABLE
- Downstream A
- Upstream A

Signal to Noise Ratio Alarm Threshold:

- Downstream A
- Upstream A

Figure 8-1

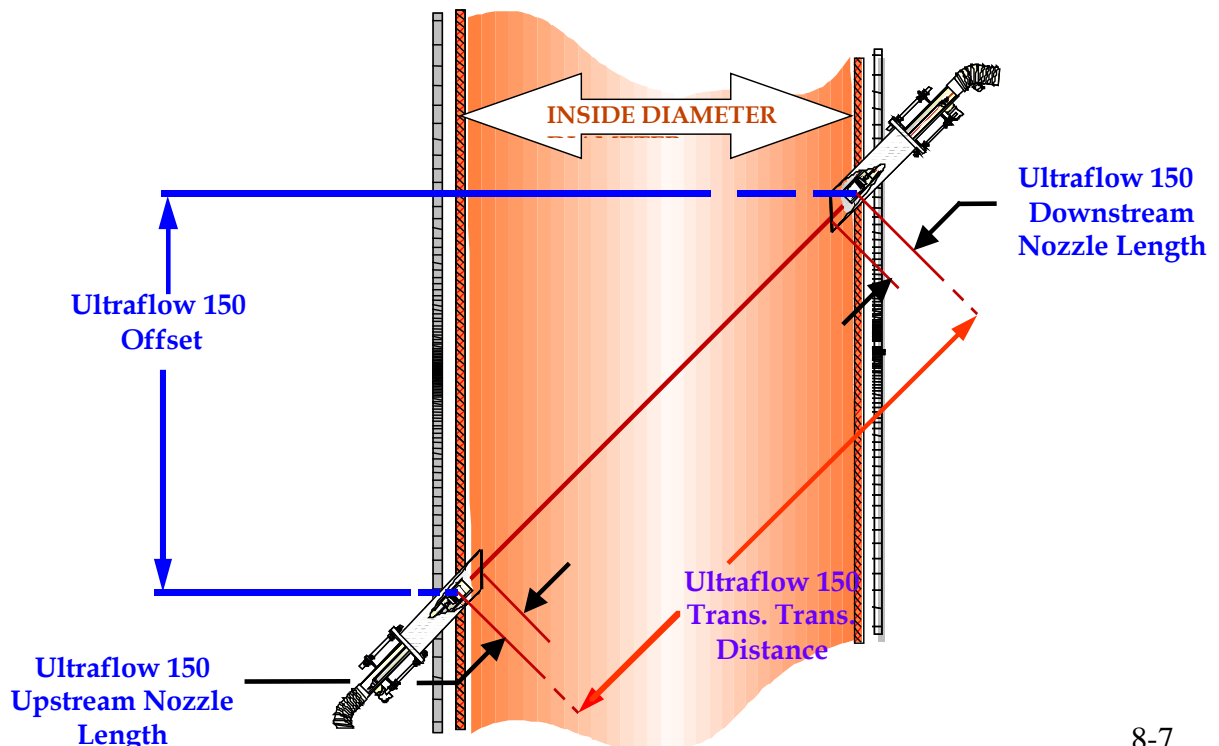

8.2 TRANSDUCER INTERFACE ENCLOSURE ELECTRONICS ADJUSTMENT

8.2.1 Flow Mother Board

No user adjustments to this board are required. However, configuration device U5 must be compatible with the transducer type in use (Electrostatic, Long Range or Extended Long Range).

8.2.2 Preamp Board Adjustment

No user adjustments to the board are required

8.3 REMOTE PANEL CALIBRATION

8.3.1 Remote Program Variables

The configuration of the Enhanced Remote Panel is controlled by the entering of the program variables. Appendix A may be consulted for the values entered by Teledyne Monitor Labs at the time of factory calibration. As was mentioned previously, these values may also be user modified to reflect differing or changing site conditions. Additional information on the Enhanced Remote Panel variables may be found in Section 6.0.

8.3.2 Enhanced Remote Panel Analog Adjustments

Section 6.0 should be consulted for additional information on the circuits and displays of the Enhanced Remote Panel.

(This page intentionally left blank.)

9.0 MAINTENANCE

In the long term, the reliability and accuracy of any continuous monitoring system depends on the implementation of a conscientious regularly scheduled maintenance program. If care is taken to perform simple inspections and take corrective action as required, the Teledyne Monitor Labs Ultraflow 150 system will provide accurate, reliable data to the user.

9.1 MAINTENANCE SCHEDULE

It must be noted that the conditions under which the monitoring system operates varies widely from installation to installation. However, Teledyne Monitor Labs has found the following schedule to be more than adequate to provide high monitor availability.

9.1.1 After Initial Installation

Teledyne Monitor Labs recommends that the Purge Nozzle Assemblies be removed from the mounting tubes for visual inspection approximately 30 days after installation and again at 30-day intervals for only the first 3 months of operation. This is a check to see that the purge air being supplied to the Nozzle Assemblies is adequate and to confirm that the normal maintenance schedule routine will be sufficient. During these initial inspections, Teledyne Monitor Labs recommends that the "Teledyne Monitor Labs Maintenance Check Sheets for the Ultraflow 150" be used to record the data collected while performing this maintenance. The "Teledyne Monitor Labs Maintenance Check Sheets for the Ultraflow 150" and Teledyne Monitor Labs "Procedure for Maintenance Check Sheets for the Ultraflow 150" are located in Appendix B.

9.1.2 Normal Maintenance

Under normal circumstances, Teledyne Monitor Labs recommends that the maintenance check be performed at least quarterly, but generally not more often than every two months. The exception to this recommended schedule would be if the initial inspections performed after installation revealed that the ambient conditions of the monitor were so adverse that they require the purge air filters to be changed more frequently. Extremely dusty conditions in the area of the purge blower will cause the inlet filter to clog, thus reducing the volume of the protective purge air. Actual site experience must be used in order to develop an adequate replacement schedule for the purge air filters.

It should be noted that in performing the maintenance on the flow system that the monitor may remain on line and collecting data while performing the check. The exception is when the Purge Nozzle Assemblies are removed for inspection. Removal of the Purge Nozzle Assemblies will

cause the data to be invalid. The Purge Nozzle Assemblies need not be removed during each maintenance; however, Teledyne Monitor Labs recommends that the transducers be visually inspected approximately every six months.

9.2 TROUBLESHOOTING GUIDE

One of the design features of the Ultraflow 150 system is that all of the information necessary to troubleshoot the system to a subassembly level can be obtained from the Enhanced Remote Panel. The Status Codes together with the Service Data Values will define almost any system problem.

If a Fault is indicated or you suspect a problem:

- Go to the Enhanced Remote Panel and write down the status word and Service Data values.
- Decode the status word according to the help screen or tables of section four. This alone may point to the problem.
- Compare the Service Data readings to the readings from your last maintenance check sheet.

If at this point the problem is not apparent:

- Go through the maintenance check sheet procedure (Appendix B).
- Review this data for the proper ranges and compare it to those of previous maintenance.

If at this point you have not been able to determine the problem:

- Call the Teledyne Monitor Labs tech support line (800) 846-6062. A factory trained technician with years of experience will handle your call. Please have available:
 - Instrument model and serial number
 - Data collected in the maintenance document above

APPENDIX A

SITE SPECIFICATION DATA SHEETS

ULTRAFLOW 150 GAS FLOW AND TEMPERATURE MONITOR

(This page intentionally left blank.)

**Ultraflow 150
Site Specification Data Sheets**

Serial Number: [Redacted]
 Stack/Unit ID: [Redacted]
 TIE number: [Redacted]
 Active Paths: [Redacted]
 Transducer: [Redacted]
 System Type [Redacted]
Nose Material: [Redacted]

SO Number: [Redacted]
 Geometry: [Redacted]
 Volume: [Redacted]

Coupling Length:

	Path A			Path B	
Upstream	[Redacted]	in		[Redacted]	in
DownStream	[Redacted]	in		[Redacted]	in

LinkRod Length: (if applicable)

	Path A			Path B	
Upstream	[Redacted]	in		[Redacted]	in
DownStream	[Redacted]	in		[Redacted]	in

Junction Box Assemblies

Buffer Board

		Path A			Path B	
UpStream	PN:	[Redacted]		PN:	[Redacted]	
	SN:	[Redacted]		SN:	[Redacted]	
DownStream	PN:	[Redacted]		PN:	[Redacted]	
	SN:	[Redacted]		SN:	[Redacted]	

Jumper Positions: JU1: [Redacted] JU2: [Redacted]

TIE Enclosure PN: [Redacted]

Motherboard	PN:	[Redacted]	SN:	[Redacted]
CPU Board	PN:	[Redacted]	SN:	[Redacted]

Software Versions

332 version [Redacted]
 Neuron version [Redacted]
 FPGA version [Redacted]

Motherboard

Test Point	VDC	VAC
TP2	[Redacted]	[Redacted]
TP3	[Redacted]	[Redacted]
TP9	[Redacted]	[Redacted]
TP12	[Redacted]	[Redacted]
TP13	[Redacted]	[Redacted]
TP16	[Redacted]	[Redacted]

ULTRAFLOW 150 GAS FLOW AND TEMPERATURE MONITOR

PRE AMPS

	Path A	Path B
UpStream	PN: [redacted] SN: [redacted]	PN: [redacted] SN: [redacted]
DownStream	PN: [redacted] SN: [redacted]	PN: [redacted] SN: [redacted]

Jumper positions 1903-0400 Pre Amps (N/A for 1903-0200)

JU1: [redacted]	JU2: [redacted]	JU3: [redacted]
JU4: [redacted]	JU5: [redacted]	

Dual Analog Input Board

PN: [redacted] SN: [redacted]

Barometric Pressure Sensor: [redacted]
LON Modlue: [redacted]
External BP: [redacted]
External Temp.: [redacted]

Averaging Properties

Integration Per Sec: [redacted] Acquire Mode Avg: [redacted]
Integration Per Avg: [redacted]

Auto Cal Cycle

CAL Time Hour: [redacted]
CAL Time Min: [redacted]
CAL Interval Hour: [redacted]

Span HI Set Point: [redacted]
Span LO Set Point: [redacted]
Zero Set Point: [redacted]
Cal Tolerance: [redacted]

IP Auto Span HI: [redacted]
IP Auto Span LO: [redacted]
IP Auto Zero: [redacted]

LUI Display Board

PN: [redacted] SN: [redacted]

6PIO Board

PN: [redacted] SN: [redacted]

Jumper Positions

JU1: [redacted]	JU9: [redacted]
JU2: [redacted]	JU10: [redacted]
JU3: [redacted]	JU11: [redacted]
JU4: [redacted]	JU12: [redacted]
JU5: [redacted]	JU13: [redacted]
JU6: [redacted]	JU14: [redacted]
JU7: [redacted]	JU15: [redacted]
JU8: [redacted]	

APPENDIX A, SITE SPECIFICATION DATA SHEETS

6PIO Analog Outputs

#1
Cal Type
Path
Zero Scale
Full Scale

#2
Cal Type
Path
Zero Scale
Full Scale

6PIO Relay Outputs

K1 (JU12)
K2 (JU13)

Enhanced Remote Display

PN: SN:

Software Versions
332 version
Panel Neuron
MIO version

Ethernet Module PN: SN:
MAC Address:

Neuron Version:
WEB Server Version:

Remote Motherboard PN: SN:
CPU Board PN: SN:
MIO Board PN: SN:

Analog Outputs

#1
Cal Type
Path
Zero Scale
Full Scale

#2
Cal Type
Path
Zero Scale
Full Scale

ULTRAFLOW 150 GAS FLOW AND TEMPERATURE MONITOR

#3
Cal Type
Path
Zero Scale
Full Scale



#4
Cal Type
Path
Zero Scale
Full Scale



Relays

K1
K2
K3
K4
K5
K6
K7
K8

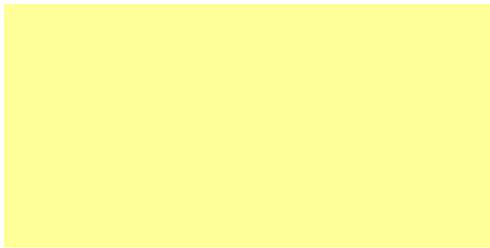

Test Equipment Used

DMM
Oscilloscope
Chart Recorder



APPENDIX B

MAINTENANCE CHECK SHEETS

(This page intentionally left blank.)

Rev. 9/8/11

**TELEDYNE MONITOR LABS INC.
MAINTENANCE CHECK SHEETS FOR THE ULTRAFLOW 150**

Company		Date:	Time:
Plant Name		Service Person	
Location		Load Level	
Unit ID		TIE	
Serial Number		Path	

Reason for Service	
---------------------------	--

Data Invalid From		Data Invalid To	
--------------------------	--	------------------------	--

SERVICE DATA

	Before	After
Signal to Noise DnStream		
Signal to Noise UpStream		
PreAmp Gain DnStream		
PreAmp Gain UpStream		
Digital Gain DnStream		
Digital Gain UpStream		
DnStream Noise Threshold		
UpStream Noise Threshold		

NUMERICAL DATA

Flow Data

Record only the Average values.

	Before	After
Linearized Velocity		
Raw Velocity		
Actual Volume		
Standard Volume		
Span High Volume		
Span Low Volume		
Zero Volume		

Internal Temperature Data

Record only the Average values.

	Before	After
Speed of Sound		
Medium Temp. Internal		

External Temperature and Pressure

Record only the Average values.

	Before	After
Medium Temp. External		

ULTRAFLOW 150 GAS FLOW AND TEMPERATURE MONITOR

Medium Pressure		
------------------------	--	--

SOFTWARE VERSIONS

	Before	After
Panel 332		
Panel Neuron		
TIE 332		
TIE Neuron		
MIO		
FPGA		

Review the Status History and Alarm History screens and record anomalies below.

STATUS HISTORY

ALARM HISTORY

TRANSDUCER CHECKS

- 1. Replace Purge Air Filters.
- 2. Clean Down Stream Transducer and Mounting Tube.
- 3. Clean Up Stream Transducer and Mounting Tube.

TIE ELECTRONICS

Check the following Power Supply voltages on the Ultraflow 150 Mother Board. TP15 = DGND.

TP	VDC	VDC	VDC	VAC (< .005 VAC)
TP2	(+120 VDC to 140 VDC)		VDC	VAC (< .005 VAC)
TP3	+5 VDC (± .15 VDC)		VDC	VAC (< .005 VAC)
TP9	+15 VDC (± .30 VDC)		VDC	VAC (< .005 VAC)
TP12	-15 VDC (± .30 VDC)		VDC	VAC (< .005 VAC)
TP13	+3.3 VDC (± .15 VDC)		VDC	VAC (< .005 VAC)
TP16	+2.5 VDC (± .10 VDC)		VDC	VAC (< .005 VAC)

If this maintenance is just prior to a RATA or is being done as part of an Emergency Repair:

- 1. Compare the System Properties to the last recorded parameters.
- 2. Check and adjust the Pressure calibration.
- 3. Check and adjust the External Temperature calibration.
- 4. Check and adjust the Analog Outputs.

Force the monitor through a calibration and record the results.

ZERO CAL SETPOINT	ZERO CAL VALUE
SPAN LOW CAL SETPOINT	SPAN LOW CAL VALUE
SPAN HIGH CAL SETPOINT	SPAN HIGH CAL VALUE

COMMENTS

--

PROCEDURE FOR MAINTENANCE CHECK SHEETS FOR THE *ULTRAFLOW 150*

Record the company's name and the plant name of where the flow monitor is located. The location can be the name of the city or the street where the plant is located. The serial number can be found on the back of the Enhanced Remote Panel. Some Ultraflow 150's have two TIE boxes networked to one Enhanced Remote Panel. Record which one you are servicing. Some Ultraflow 150's can have both a Path A and a Path B for each TIE. If the TIE you are working on has both, start a sheet for PATH B and the combined Path (PATH AB).

All of the data recorded can vary depending on the process and the load range of the process. The data is best used when compared to historical records. This shows the importance of recording the Load Level. This can be Mega Watts, Steam Load, or a Process Level.

The **SERVICE DATA** screen is easily accessible from the main display by pressing the enter button twice. Select which TIE and Path you are interested in. Fill in the "**Before**" section of this table with information from the Fundamental and Advanced screens.

The **NUMERICAL DATA** can be found by pressing the enter button once and then moving down the Main Menu by using the down arrow button. Select which TIE you are interested in. There are three screens you need to get into to obtain data. Record the Average values from the **Flow Data**, **Internal Temperature Data**, and **External Temperature and Pressure** screens. If the Ultraflow 150 monitor does not use the External Temperature or Pressure inputs, enter NA.

The **SOFTWARE VERSIONS** can easily be found by pressing the enter button once from the Main Display and then using the down arrow to get to the Software Versions screen. Record the values before any maintenance is done.

The **STATUS HISTORY** and **ALARM HISTORY** screens both may contain several pages. They can be found by pressing the enter button once from the Main display and using the down arrow to get to the bottom of the Main Menu. Check both the Primary and an Extended Status screens for your appropriate configuration. Any recent anomaly should be noted. The Status Codes can be decoded with the Status Help.

The **TRANSDUCER** and **TIE ELECTRONICS** checks are done at the measurement location. This is typically on a stack or duct. Teledyne Monitor Labs Inc. recommends checking the purge air filters on a monthly basis after the installation. Most sites find it necessary to replace the filters every three months. Some sites may need to replace them more often and others may decide to create their own maintenance schedule. The Part Number for the filter is 820202.

The transducers and mounting tubes are easy to check and clean. Undo the latches holding the transducer assembly. Inspect the end of the transducers and gently remove any ash or other debris. A foam insert is included in the end of some of the transducers. Its part number is 1001-0103-01. If you have this type of transducer, it can be replaced or cleaned. The mounting tubes should be inspected with a strong flashlight. Some buildup can occur near the end that sticks into the effluent. This can be hard to detect since the buildup is often uniform.

Record the TIE Electronics power supply voltages. They are located on the large P.C. board in the TIE box. Its Part Number is 1903-0100. A drawing is included to help locate the test points.

ULTRAFLOW 150 GAS FLOW AND TEMPERATURE MONITOR

Additional maintenance may be done prior to a Relative Accuracy Test Audit or when troubleshooting a problem during an emergency repair. This includes comparing the configuration variables located in the System Properties screens, checking or adjusting the Pressure or External Temperature calibration, and checking the calibration of the Analog Outputs. The Analog Outputs can easily be forced to 4 mA, 12 mA, and 20 mA from the Output and Cal Tests screen in the Enhanced Remote Display. They should respectively correspond to zero, mid, and full scale on the end recording device. Additional information is located in the body of the manual and is available from Teledyne Monitor Labs technical support via phone.

Force a calibration cycle. Then go back and record data in the "After" columns of the data tables.

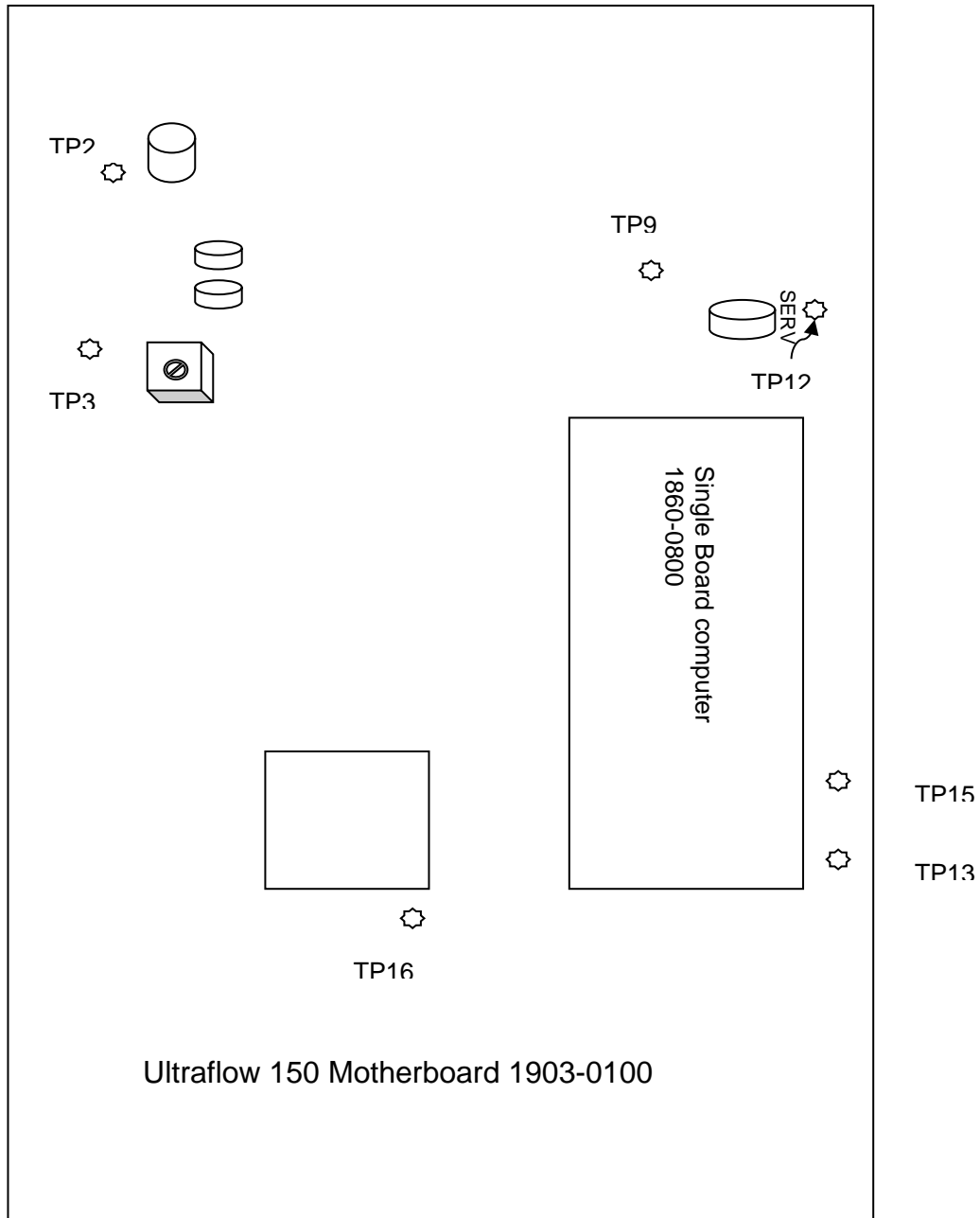

APPENDIX C
SPARE PARTS

(This page intentionally left blank.)

RECOMMENDED SPARE PARTS

Recommended spare parts for the Ultraflow 150 are organized into three categories. User can stock the appropriate parts for their level of maintenance. For the highest level of maintenance all three lists should be stocked. The three levels are:

- ❑ Startup
 - Parts that may be used during start-up and daily operation.
- ❑ Maintenance
 - Parts that may be required as a result of normal wear over time.
- ❑ Emergency
 - Parts that will facilitate the fastest possible repair time in failure situations such as power surges, lightning strikes, etc.

TELEDYNE MONITOR LABS (TML) ULTRAFLOW 150 “STARTUP” RECOMMENDED SPARE PARTS						
(Parts and materials which should be purchased prior to or during system startup and operation)						
			Quantity to Stock			
Part Name	TML Part No.	System Location	1 on Site	2 – 5 on Site	5 - 10 on Site	Mean Time Between Replacement
Fuse	527438	Enhanced Remote Panel	5	5	10	N/A
Fuse	527441	Power Supply in TIE	5	5	10	N/A

TELEDYNE MONITOR LABS (TML) ULTRAFLOW 150 “MAINTENANCE” RECOMMENDED SPARE PARTS						
(Parts which are used during the normal operation of the monitors over time)						
			Quantity to Stock			
Part Name	TML Part No.	System Location	1 on Site	2 – 5 on Site	5 - 10 on Site	Mean Time Between Replacement
Fuse	527438	Enhanced Remote Panel	5	5	10	N/A
Fuse	527441	Power Supply in TIE	5	5	10	N/A
Purge Filter (Box of 12)	820202	Purge System	12	24	48	As Needed
*Purge Switch	1001-0700-03	Purge System	2	4	6	1-2 Years
**Purge Switch	1901-0600-01	Purge System	2	4	6	1-2 Years
Foam Insert	1001-0103-01	Transducer Assembly	2	6	12	As Needed
Transducer – Electrostatic (Standard)	1901-0200-01	Transducer Assembly	2	4	8	1 Year
Transducer - Long Range	1001-1200-01	Transducer Assembly	2	4	8	1 Year
Transducer – Extended Long Range	1001-1400-01	Transducer Assembly	2	4	8	1 Year

*Dual 42 CFM or Single 110 Blower Systems

**Single 42 CFM Blower System

ULTRAFLOW 150 GAS FLOW AND TEMPERATURE MONITOR

TELEDYNE MONITOR LABS (TML) ULTRAFLOW 150 "EMERGENCY" RECOMMENDED SPARE PARTS						
(Parts which may be necessary to minimize instrument "Down Time" after power surges, lightning strikes, etc.)						
Part Name	TML Part No.	System Location	Quantity to Stock			Mean Time Between Replacement
			1 on Site	2 - 5 on Site	5 - 10 on Site	
*Blower Motor	980142	Purge System	1	1	2	3-5 Years
*Blower Motor	980111	Purge System	1	1	2	3-5 Years
BNC Coax Connector (RG 180)	526512	Probe Assembly	2	4	6	As Needed
**Preamp PCB Electrostatic (Standard)	1903-0200-01	TIE Box	2	4	6	N/A
*** & ****Preamp PCB Long Range	1903-0400-02	TIE Box	2	4	6	N/A
***Buffer PCB Long Range	1906-0100-02	Junction Box	2	4	6	N/A
****Buffer PCB Extended Long Range	1906-0100-03	Junction Box	2	4	6	N/A
Enhanced Remote Mother Board PCB	1803-2200-03	Enhanced Remote Panel	1	1	2	N/A
Multi I/O PCB	1803-2500-04	Enhanced Remote Panel	1	1	2	N/A
LCD Display	1803-1400-02	Enhanced Remote Panel	1	1	2	N/A
Power Supply PCB (Remote)	1803-0300-02	Enhanced Remote Panel	1	1	2	N/A
Power Supply PCB (TIE)	1860-1100-02	TIE Box	1	1	2	N/A
**TIE Mother Board (Standard, w/Computer Module)	1903-0100-01	TIE Box	1	1	2	N/A
***TIE Mother Board (Long Range, w/Computer Module)	1903-0100-02	TIE Box	1	1	2	N/A
****TIE Mother Board (Extended Long Range, w/Computer Module)	1903-0100-03	TIE Box	1	1	2	N/A
External Interface PCB	1903-1500-01	TIE Box	1	1	2	N/A
Li-SOCl ₂ Battery, Non-rechargeable, 3.6V, 1.1 Ah, 1/2AA Size	550047	TIE Box and Enhanced Remote Panel	1	1	2	5-10 Years
6PT I/O PC Board UF150DI ONLY	1860-0700-01	TIE Box	1	1	2	N/A

*The blower motor supplied with each system is dependent on effluent parameters. Consult the system configuration parameters for your monitor for the proper blower motor.

These parts are used on **standard monitors only. Consult the system configuration parameters for your monitor to determine applicability.

***These parts are used on **long range monitors only**. Consult the system configuration parameters for your monitor to determine applicability.

****These parts are used on **extended long range monitors only**. Consult the system configuration parameters for your monitor to determine applicability.

REVOLUTIONS		DATE	APPD.
ZONE	SYM.	DESCRIPTION	
A		PER DCN #1900-0090A	10-14-02 ELM
B		PER DCN #1900-0090B	6-1-07 ELM
C		PER DCN #1900-0090C	9-8-14 IE

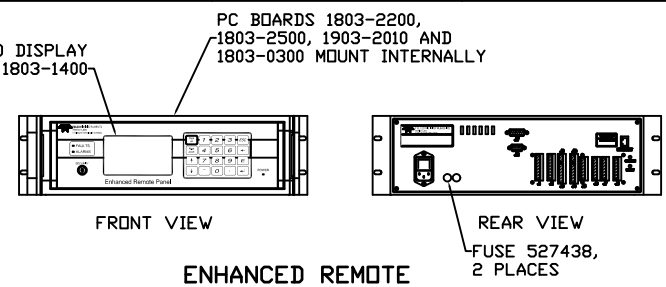
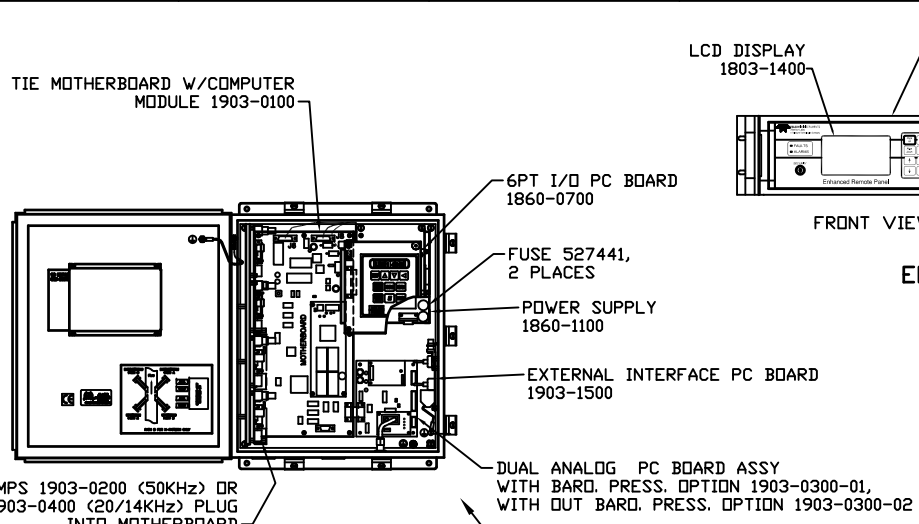

ENHANCED REMOTE PANEL
1/4 SCALE

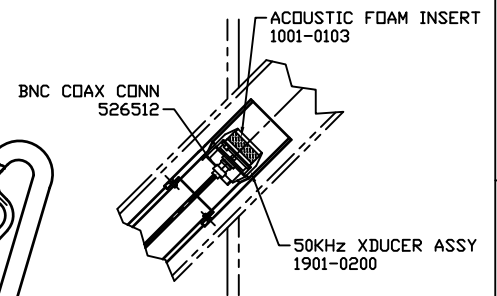

VIEW A
50KHz XDUCER
3/8 SCALE

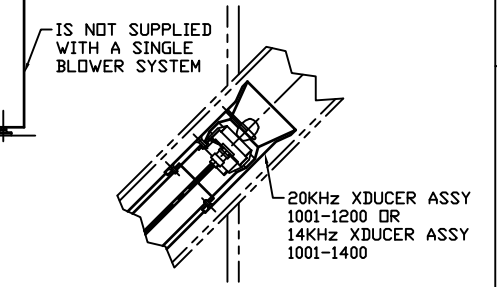

VIEW A
20/14KHz XDUCER
3/8 SCALE

TRANSDUCER INTERFACE ENCLOSURE
1/4 SCALE

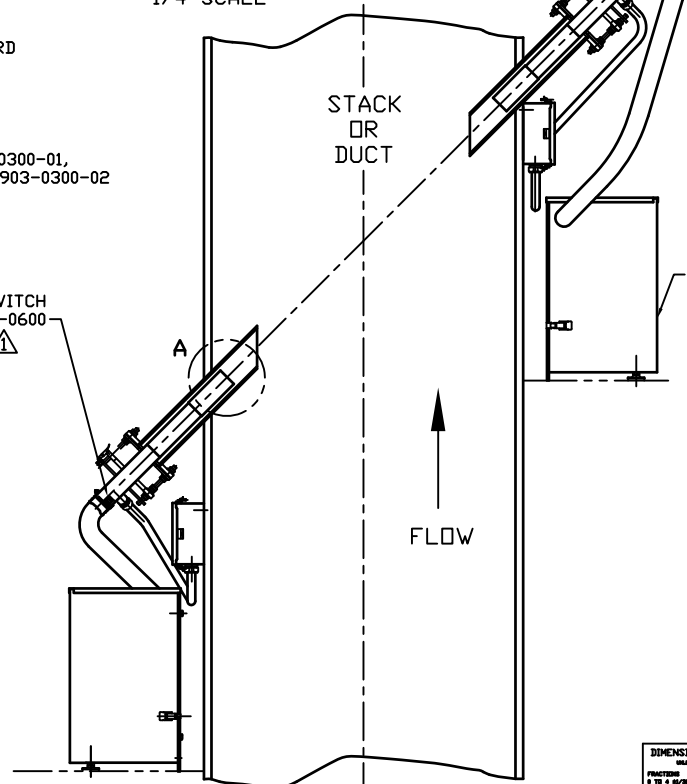
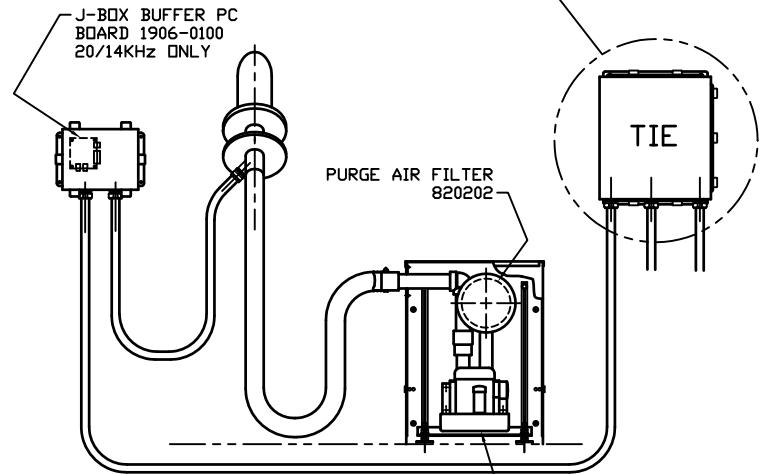

⚠ 1901-0600 IS USED WITH SINGLE 42CFM BLOWER SYSTEM ONLY.

PURGE BLOWER 980142, DUAL 42CFM OR SINGLE 42CFM BLOWER SYSTEM
PURGE BLOWER 980111, SINGLE 110CFM BLOWER SYSTEM

SPARE PARTS LOCATION

DIMENSIONAL TOLERANCES UNLESS OTHERWISE SPECIFIED		USED ON		TELEDYNE MONITOR LABS Everywhereyoulook	
FRACTIONS	DECIMALS	DRAWN	DATE	BY	DATE
1/16 TO 1/8	0.005	EAS	5-3-02	EAS	5-3-02
3/16 TO 1/2	0.010	CHECKED	EAS	10-1-02	
1/2 TO 1	0.015	DESIGNED	EAS	May-02	
1 TO 2	0.020	ENGINEERED	ELM	10-16-02	
2 TO 4	0.030	PRODUCTION	PD	10-16-02	
4 TO 8	0.040	G.A.	AS	10-16-02	
8 AND UP	0.050				
ALL DIMENSIONS ARE IN INCHES DO NOT SCALE THESE DRAWINGS		AUTHORIZATION		FINISH	
		MATERIAL		SCALE	
		JOB NO.		SHEET	
		DRAWING NO.		1 of 1	
		D 1900-0090		C	

ACADEMY FILE 19000090

APPENDIX D

DRAWINGS

(This page intentionally left blank.)

REVISIONS				
ZONE	SYM.	DESCRIPTION	DATE	APPD.
	A	PER DCN #1900-0001A	6-21-02	DMB
	B	PER DCN #1900-0001B	9-12-02	ELM
	C	PER DCN #1900-0001C	11-20-02	ELM
	D	NO CHANGE THIS SHEET	5-24-05	ELM

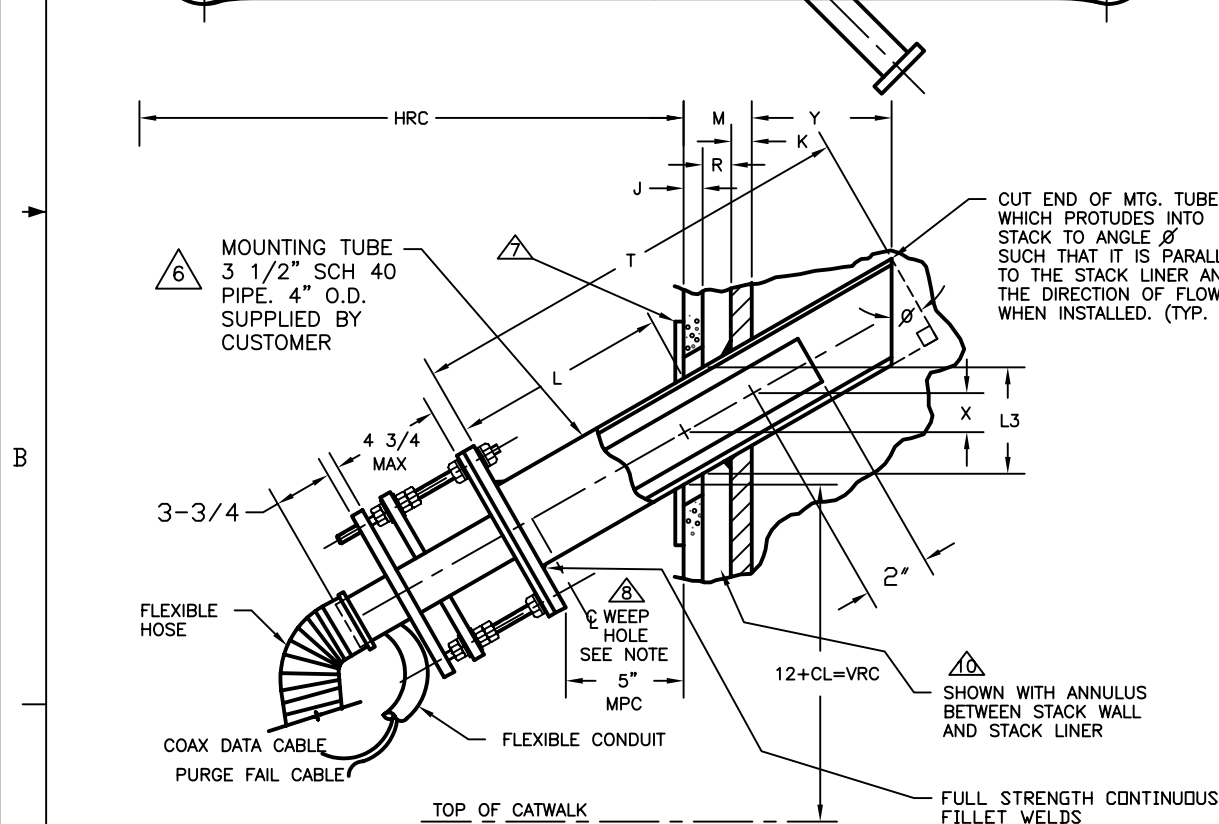
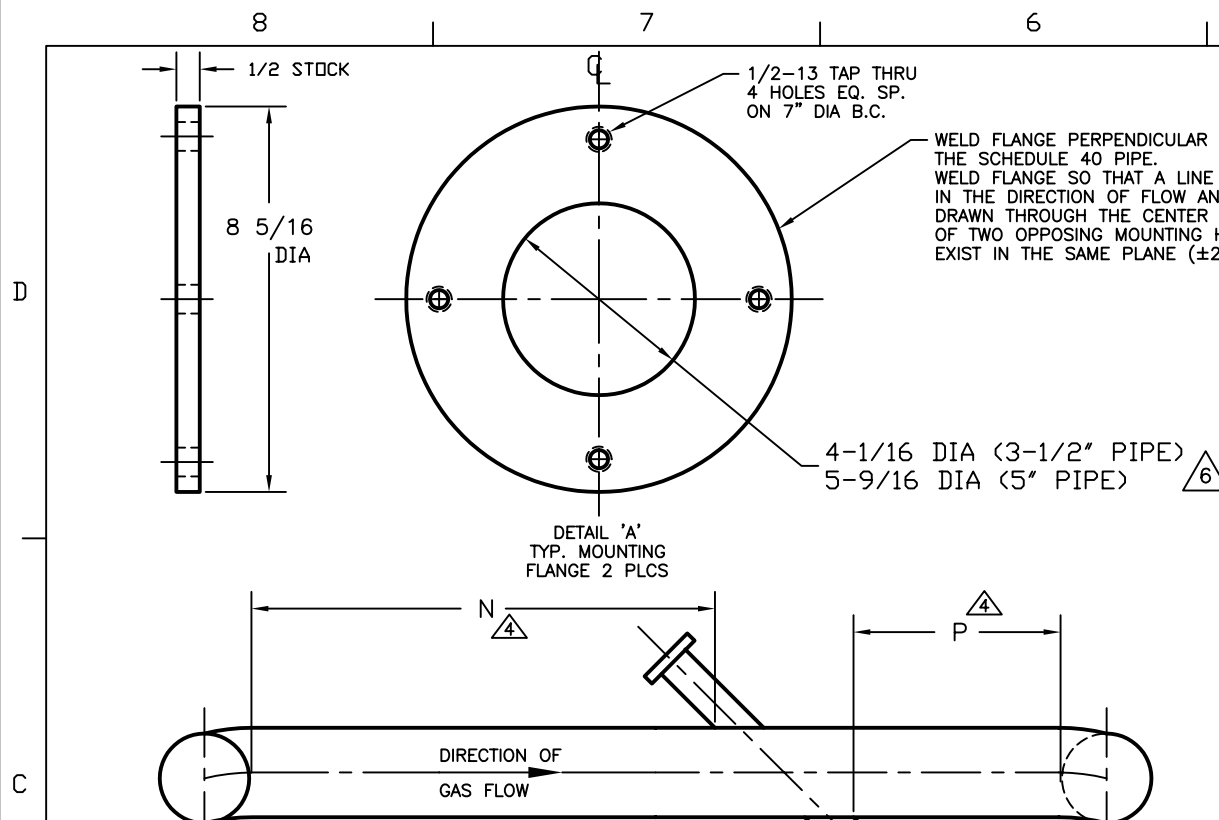

NOTES

1. SEE DRAWING 1900-0006 FOR X-PATTERN.

2. CUSTOMER MUST PROVIDE SAFE ACCESS PLATFORMS, CATWALKS AND LADDERS TO EACH TRANSDUCER FOR INSTALLATION PERSONNEL.

3. FOR $D \geq 5'$: $5' \leq H \leq D$
FOR $D < 5'$: $H=5'$
FOR LONG RANGE TRANSDUCER OPTIONS OR OFFSETS $< 5'$ CONSULT FACTORY.
FOR H FOR X-PATTERN, SEE DRAWING 1900-0006.
FOR MOUNTING ANGLE $< 45^\circ$ IN APPLICATIONS WITH MULTIPLE STACK INLETS OR WITH CONDITIONS WITH MULTIPLE STACK INLETS OR WITH CONDITIONS

4. NOT MET, X-PATTERN MIGHT BE REQUIRED. (CONSULT FACTORY)

5. TRANSDUCER FLANGES SHOULD BE MOUNTED SO THAT ϕ OF FLANGES IS PERPENDICULAR TO THE PLANE OF THE LAST UPSTREAM BEND.

6. 3-1/2\"/>

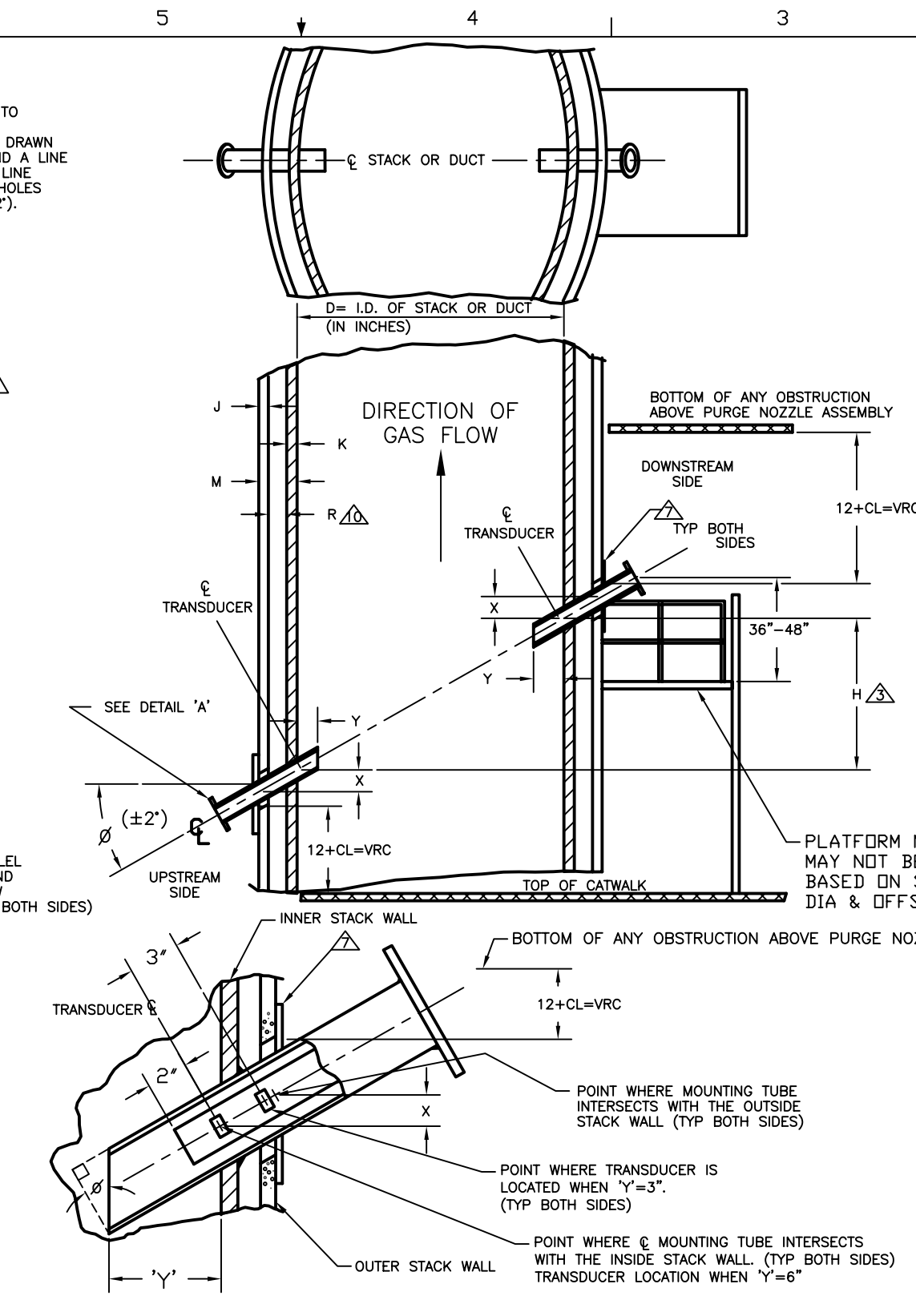

TYPICAL DOWNSTREAM SIDE

7. VERIFY THAT 'N' AND 'P' SATISFY THE CONDITIONS DESCRIBED IN NOTES.

8. DETERMINE 'MPC' (5\"/>

9. THE ULTRAFLOW CALIBRATION IS AFFECTED BY THE ACCURACY OF 'L', 'H' AND 'X'. STAYING WITHIN TOLERANCE FOR THESE DIMENSIONS WILL MINIMIZE THE NEED FOR AND DEGREE OF FIELD RECALIBRATION.

10. IF ANNUAL SPACE EXCEEDS 4\"/>

DEFINITIONS:

H = DOWNSTREAM DISTANCE BETWEEN CENTER LINES OF DOWNSTREAM AND UPSTREAM TRANSDUCERS. (IN INCHES)

J = THICKNESS OF OUTER STACK WALL. (IN INCHES)

K = THICKNESS OF STACK LINER OR INNER STACK WALL (WHERE APPLICABLE). (IN INCHES)

L = LONGER OF TWO DISTANCES FROM BACK OF FLANGE TO OUTER STACK WALL. (IN INCHES)

L3 = MAJOR AXIS OF ELLIPTICAL HOLE IN STACK REQUIRED FOR INSTALLING MOUNTING TUBE. (IN INCHES)

M = TOTAL DISTANCE FROM OUTSIDE OF STACK TO BEGINNING OF INNER DIAMETER. (IN INCHES)

MPC = MOUNTING PLATE CLEARANCE. (5\"/>

N = DISTANCE FROM THE UPSTREAM TRANSDUCER MOUNTING TUBE TO THE END OF THE LAST UPSTREAM BEND IN A STACK OR DUCT. (IN FEET)

P = DISTANCE FROM THE DOWNSTREAM TRANSDUCER MOUNTING TUBE TO THE BEGINNING OF THE NEXT DOWNSTREAM BEND IN A STACK OR DUCT. (IN FEET)

R = THICKNESS OF ANNULAR SPACE (WHERE APPLICABLE) SEE NOTE 10

T = LENGTH OF TUBE TO WHICH FLANGE IS MOUNTED. (IN INCHES)

X = DISTANCE BETWEEN THE POINTS WHERE THE CENTER LINE OF THE MOUNTING TUBE INTERSECTS THE INSIDE & OUTSIDE OF THE STACK WALL. (IN INCHES)

Y = 6\"/>

ϕ = ANGLE BETWEEN CENTER LINES OF MOUNTING TUBES AND AN INTERSECTING AXIS NORMAL TO THE DIRECTION OF FLOW.

12+CL = FOR THE UPSTREAM TRANSDUCER, THIS REFERS TO THE MINIMUM VERTICAL CLEARANCE REQUIRED FROM THE BOTTOM JUNCTURE OF THE MOUNTING TUBE AND STACK TO THE ACCESS CATWALK (OR ANY OTHER INTERVENING OBSTRUCTION). FOR THE DOWNSTREAM TRANSDUCER, THIS REFERS TO THE MINIMUM VERTICAL CLEARANCE REQUIRED FROM THE TOP JUNCTURE OF THE MOUNTING TUBE AND STACK TO THE NEAREST DOWNSTREAM OBSTRUCTION. (IN INCHES)

HRC = MINIMUM HORIZONTAL CLEARANCE FROM THE PURGE NOZZLE ASSEMBLY TO RAILINGS OR OTHER OBSTRUCTIONS. (IN INCHES)

- ORDER IN WHICH TO PERFORM CALCULATIONS:**
- 1 DETERMINE 'D' FROM STACK OR DUCT DWG'S
'D' = I.D. OF STACK OR DUCT (IN INCHES)
 - 2 DETERMINE 'H' FROM NOTE 4.
 - 3 CALCULATE ' ϕ '; $\phi = \tan^{-1}(H/D)$
 - 4 DETERMINE 'J', 'R' AND 'K' FROM STACK OR DUCT DWG'S
 - 5 CALCULATE 'M'; $M = J+K+R$
 - 6 CALCULATE 'X'; $X = M(\tan \phi)$ FOR ANNULAR SPACE ONLY
 - 7 VERIFY THAT 'N' AND 'P' SATISFY THE CONDITIONS DESCRIBED IN NOTES.
 - 8 DETERMINE 'MPC' (5\"/>
 - 9 CALCULATE 'L'; $L = (MPC/\cos \phi) + (6.125)(\tan \phi)$
 - 10 DETERMINE 'Y' FROM DEFINITIONS ABOVE.
 - 11 CALCULATE 'T'; $T = L + [(M+Y)/\cos \phi]$
 - 12 CALCULATE 'L3'; $L3 = 4.0625/\cos \phi$
 - 13 CALCULATE 'CL';
 $CL = \sin \phi [(2L+15) + (M/\cos \phi)] - (2/\cos \phi) + 4.$
 - 14 VERIFY THAT ADEQUATE CLEARANCES EXIST. BOTH CLEARANCES (VRC AND HRC) ARE NECESSARY FOR EASY REMOVAL AND INSERTION OF THE PURGE NOZZLE ASSEMBLIES (PROBES).
 - 15 CALCULATE 'HRC'; $HRC = \cos \phi(L+T+16)$
 - 16 CALCULATE 'VRC'; $VRC = 12+CL$

SEE SHEET 2 FOR METRIC

DIMENSIONAL TOLERANCES UNLESS OTHERWISE SPECIFIED		USED ON		TELEDYNE INSTRUMENTS	
FRACTIONS	DECIMALS	DASH NO	NEXT ASSEMBLY	Monitor Labs	
0 TO 4 31/32	.001	-01	UF150	A Teledyne Technologies Company	
4 TO 8 31/32	.002			THIS DOCUMENT CONTAINS PROPRIETARY AND CONFIDENTIAL INFORMATION. IT IS TO BE USED ONLY FOR THE PURPOSES SPECIFIED IN THE EVALUATION REPORT WITHOUT THE WRITTEN CONSENT OF TELEDYNE MONITOR LABS.	
8 AND UP 31/8	.005			TITLE	
ALL DIMENSIONS ARE IN INCHES UNLESS OTHERWISE SPECIFIED				ULTRAFLOW 150	
AUTHORIZATION				FLANGE INSTALLATION (ENGLISH)	
DRAWN	EAS	10-8-01	MAT'L.	FINISH	
CHECKED	EAS	Mar-02			
DESIGNED	EAS	Oct-01	JIG NO.		
ENGINEERED	ELM	4-2-02	SCALE	DRAWING NO.	
PRODUCTION	PD	4-2-02	NTS	1900-0001	
Q.A.	GRG	4/2/02	SHEET	LATEST REVISION	
			1 OF 2	D	

REVISIONS				
ZONE	SYM.	DESCRIPTION	DATE	APPD.
	A	PER DCN #1900-0001A	6-24-02	DMB
	B	PER DCN #1900-0001B	9-12-02	ELM
	C	PER DCN #1900-0001C	11-21-02	ELM
	D	PER DCN #1900-0001D	5-24-05	ELM

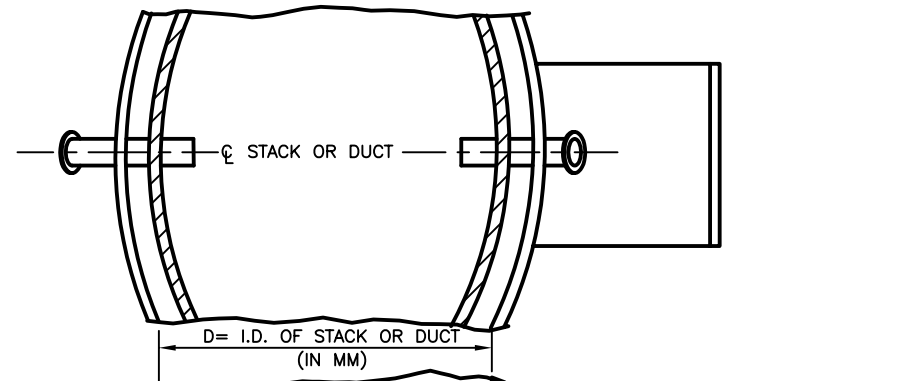
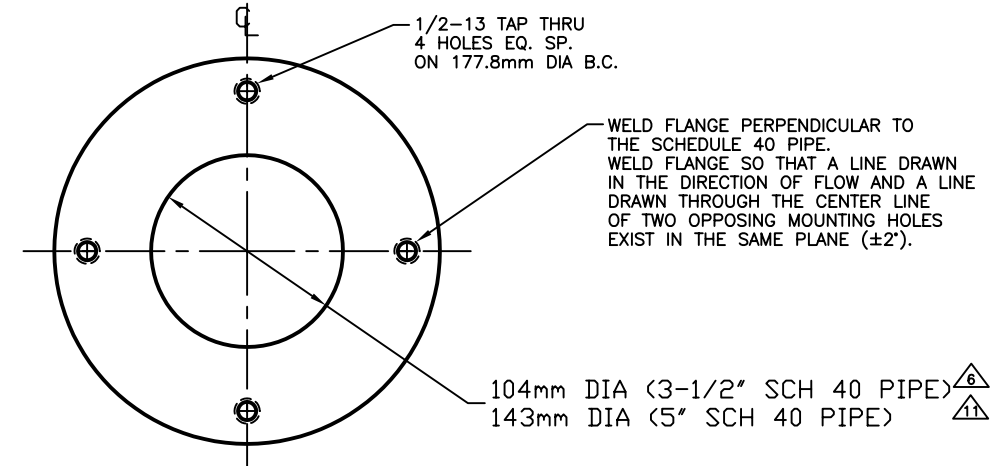

DEFINITIONS:

H = DOWNSTREAM DISTANCE BETWEEN CENTER LINES OF DOWNSTREAM AND UPSTREAM TRANSDUCERS. (IN MM)

J = THICKNESS OF OUTER STACK WALL. (IN MM)

K = THICKNESS OF STACK LINER OR INNER STACK WALL (WHERE APPLICABLE). (IN MM)

L = LONGER OF TWO DISTANCES FROM BACK OF FLANGE TO OUTER STACK WALL. (IN MM)

L3 = MAJOR AXIS OF ELLIPTICAL HOLE IN STACK REQUIRED FOR INSTALLING MOUNTING TUBE. (IN MM)

M = TOTAL DISTANCE FROM OUTSIDE OF STACK TO BEGINNING OF INNER DIAMETER. (IN MM)

MPC = MOUNTING PLATE CLEARANCE (127mm RECOMMENDED)

N = DISTANCE FROM THE UPSTREAM TRANSDUCER MOUNTING TUBE TO THE END OF THE LAST UPSTREAM BEND IN A STACK OR DUCT. (IN METERS)

P = DISTANCE FROM THE DOWNSTREAM TRANSDUCER MOUNTING TUBE TO THE BEGINNING OF THE NEXT DOWNSTREAM BEND IN A STACK OR DUCT. (IN METERS)

R = THICKNESS OF ANNULAR SPACE (WHERE APPLICABLE) SEE NOTE 10

T = LENGTH OF TUBE TO WHICH FLANGE IS MOUNTED. (IN MM)

X = DISTANCE BETWEEN THE POINTS WHERE THE CENTER LINE OF THE MOUNTING TUBE INTERSECTS THE INSIDE & OUTSIDE OF THE STACK WALL. (IN MM)

Y = 152mm FOR D=304.8cm OR GREATER, 76mm FOR D=LESS THAN 304.8cm

∅ = ANGLE BETWEEN CENTER LINES OF MOUNTING TUBES AND AN INTERSECTING AXIS NORMAL TO THE DIRECTION OF FLOW.

305mm+CL (VRC) = FOR THE UPSTREAM TRANSDUCER, THIS REFERS TO THE MINIMUM VERTICAL CLEARANCE REQUIRED FROM THE BOTTOM JUNCTURE OF MOUNTING TUBE AND STACK TO THE ACCESS CATWALK (OR ANY OTHER INTERVENING OBSTRUCTION). FOR THE DOWNSTREAM TRANSDUCER, THIS REFERS TO THE MINIMUM VERTICAL CLEARANCE REQUIRED FROM THE TOP JUNCTURE OF THE MOUNTING TUBE AND STACK TO THE NEAREST DOWNSTREAM OBSTRUCTION. (IN MM)

HRC = MINIMUM HORIZONTAL CLEARANCE FROM THE PURGE NOZZLE ASSEMBLY TO RAILINGS OR OTHER OBSTRUCTIONS. (IN MM)

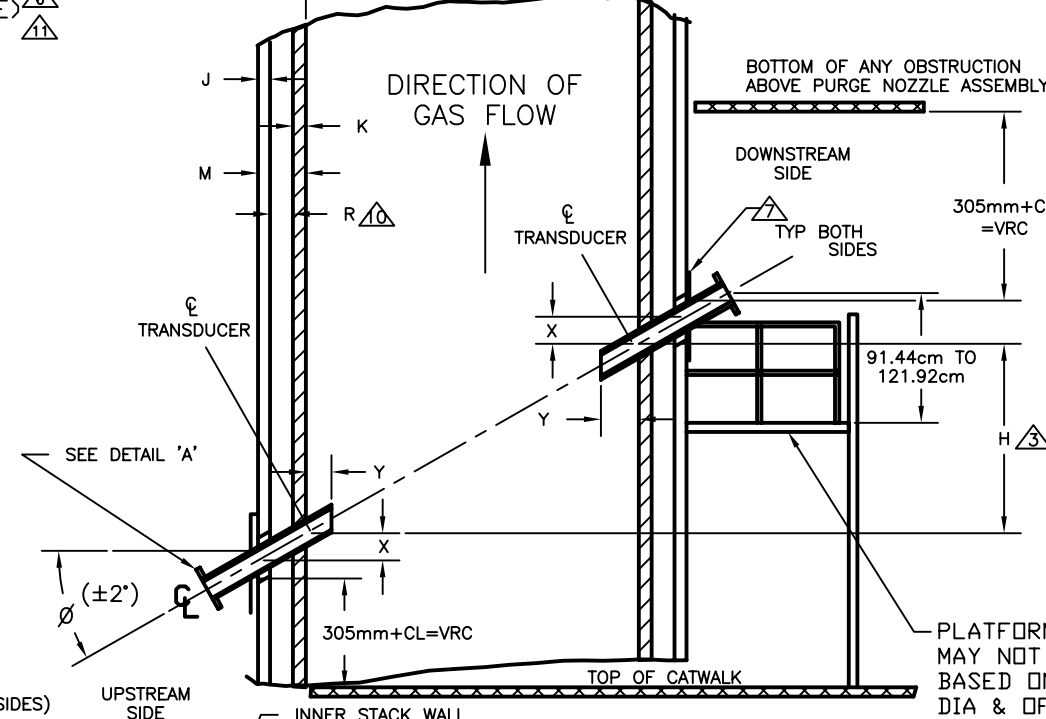
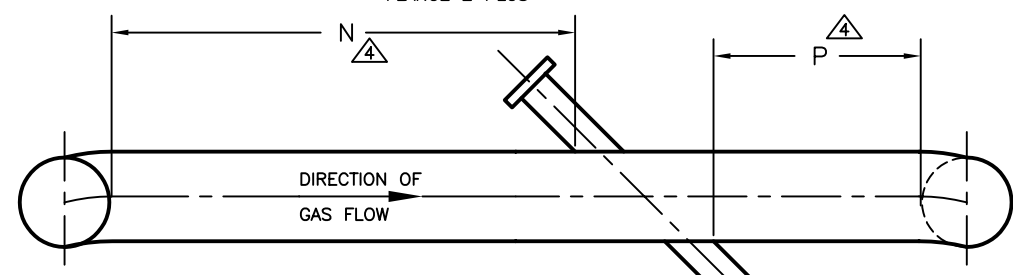

- ORDER IN WHICH TO PERFORM CALCULATIONS:**
- 1 DETERMINE 'D' FROM STACK OR DUCT DWG'S 'D' = I.D. OF STACK OR DUCT (IN MM)
 - 2 DETERMINE 'H' FROM NOTE 4.
 - 3 CALCULATE '∅'; $\theta = \tan^{-1}(H/D)$
 - 4 DETERMINE 'J', 'R' AND 'K' FROM STACK OR DUCT DWG'S
 - 5 CALCULATE 'M'; $M = J+K+R$
 - 6 CALCULATE 'X'; $X = M(\tan \theta)$ FOR ANNULAR SPACE ONLY
 - 7 VERIFY THAT 'N' AND 'P' SATISFY THE CONDITIONS DESCRIBED IN NOTES.
 - 8 DETERMINE 'MPC' (127mm RECOMMENDED)
 - 9 CALCULATE 'L'; $L = (MPC/\cos \theta) + (155.6mm)(\tan \theta)$
 - 10 DETERMINE 'Y' FROM DEFINITIONS ABOVE.
 - 11 CALCULATE 'T'; $T = L+[(M+Y)/\cos \theta]$
 - 12 CALCULATE 'L3'; $L3 = 103mm/\cos \theta$
 - 13 CALCULATE 'CL'; $CL = \sin \theta[(2L+381.0mm)+(M/\cos \theta)] - (50.8mm/\cos \theta) + 101.6mm$.
 - 14 VERIFY THAT ADEQUATE CLEARANCES EXIST. BOTH CLEARANCES (VRC AND HRC) ARE NECESSARY FOR EASY REMOVAL AND INSERTION OF THE PURGE NOZZLE ASSEMBLIES (PROBES).
 - 15 CALCULATE 'HRC'; $HRC = \cos \theta(L+T+406.4mm)$
 - 16 CALCULATE 'VRC'; $VRC = 305mm+CL$

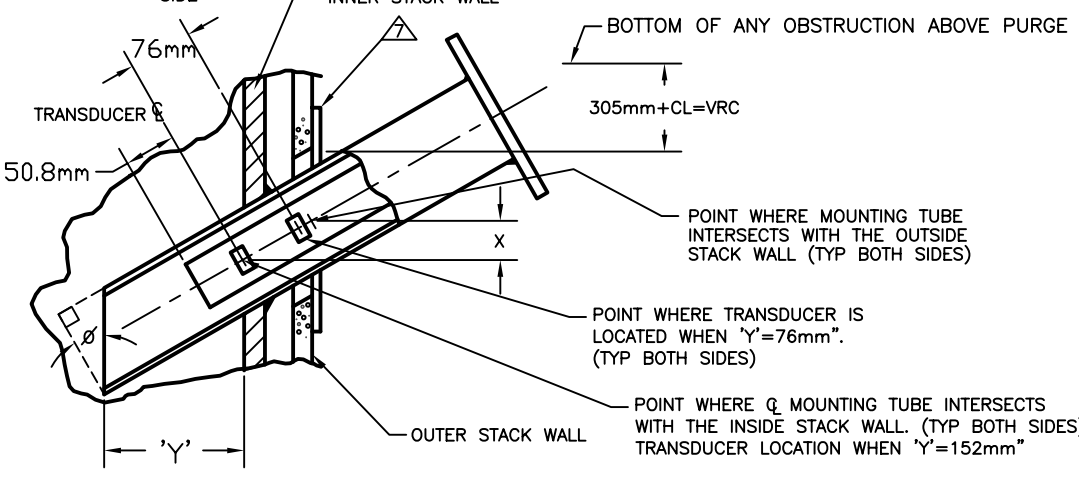
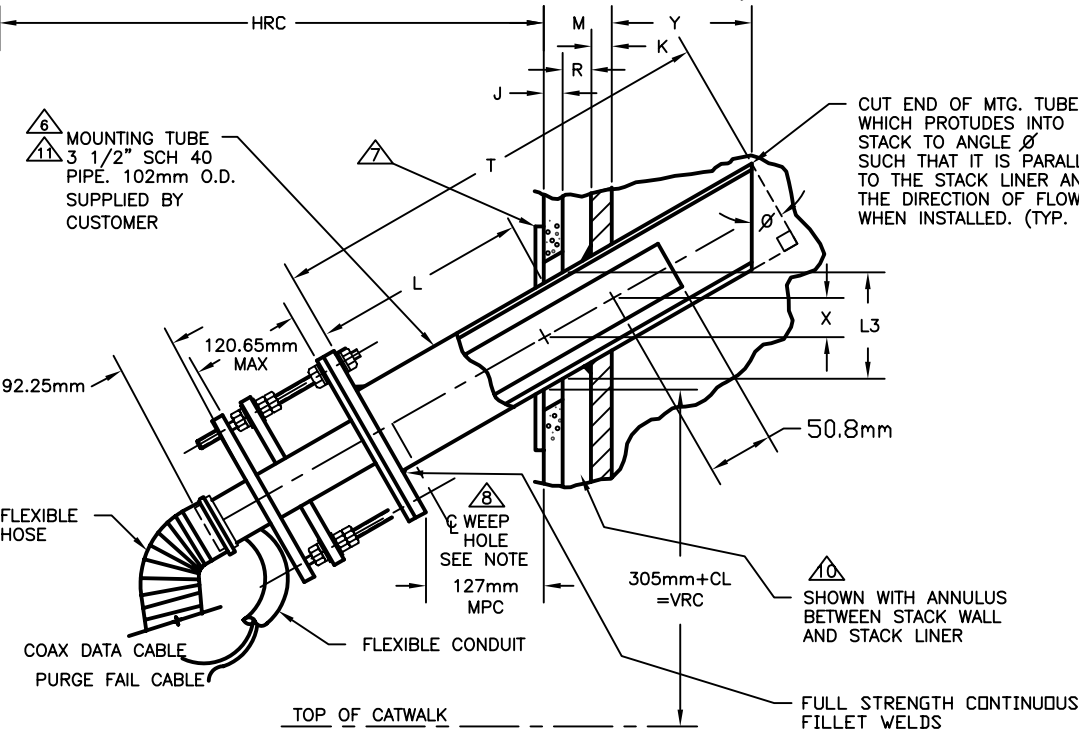

TYPICAL UPSTREAM SIDE

TYPICAL DOWNSTREAM SIDE

NOTES

1. SEE DRAWING 1900-0006 FOR X-PATTERN.
2. CUSTOMER MUST PROVIDE SAFE ACCESS PLATFORMS, CATWALKS AND LADDERS TO EACH TRANSDUCER FOR INSTALLATION PERSONNEL.
3. FOR $D \geq 152.4cm$: $152.4cm \leq H \leq D$
FOR $D < 152.4cm$: $H=152.4cm$
FOR LONG RANGE TRANSDUCER OPTIONS OR OFFSETS $< 152.4cm$ CONSULT FACTORY.
4. FOR H FOR X-PATTERN, SEE DRAWING 1900-0006. FOR MOUNTING ANGLE $< 45^\circ$ IN APPLICATIONS WITH MULTIPLE STACK INLETS OR WITH CONDITIONS NOT MET, X-PATTERN MIGHT BE REQUIRED. (CONSULT FACTORY)
5. TRANSDUCER FLANGES SHOULD BE MOUNTED SO THAT ∅ OF FLANGES IS PERPENDICULAR TO THE PLANE OF THE LAST UPSTREAM BEND.
6. 3-1/2" SCH 40 PIPE WILL BE USED IN MOST CASES. PIPE MATERIAL IS TBD BY CUSTOMER. IN RARE CASES EXTENDED RANGE TRANSDUCERS ARE REQUIRED, THEN 5" SCH 40 PIPE (141mm OD) MUST BE USED.
7. IF AN INNER LINER EXISTS AND THE MOUNTING TUBE IS ATTACHED TO THE INNER STACK LINING, AN OPENING AROUND THE MOUNTING TUBE MUST BE PROVIDED ON THE OUTER STACK WALL. THIS OPENING MUST BE LARGE ENOUGH TO ACCOMMODATE FOR MOVEMENT BETWEEN OUTER STACK WALL AND INNER LINER. CUSTOMER MUST PROVIDE, IF NECESSARY, A PROTECTIVE RUBBER BOOT OR OTHER SAFE FLEXIBLE SEALING TECHNIQUES AROUND OPENING (TYP. BOTH SIDES)
8. FOR STACK CONDITIONS HAVING FLOW WITH HIGH LEVELS OF CONDENSATION, A WEEP HOLE LOCATED AT THE BASE OF THE UPSTREAM MOUNTING TUBE MAY BE NECESSARY TO ALLOW FOR DRAINAGE. CONSULT MLI.
9. THE ULTRAFLOW CALIBRATION IS AFFECTED BY THE ACCURACY OF 'L', 'H' AND 'X'. STAYING WITHIN TOLERANCE FOR THESE DIMENSIONS WILL MINIMIZE THE NEED FOR AND DEGREE OF FIELD RECALIBRATION.
10. IF ANNULAR SPACE EXCEEDS 122cm CONSULT MLI FOR OTHER PRACTICAL INSTALLATION METHODS.
11. PIPE SIZE IS AMERICAN STANDARD.

ALL DIMENSIONS ARE METRIC

DIMENSIONAL TOLERANCES UNLESS OTHERWISE SPECIFIED		USED ON		TELEDYNE INSTRUMENTS Monitor Labs A Teledyne Technologies Company	
FRACTIONS	DECIMALS	DASH NO	NEXT ASSEMBLY	THIS DOCUMENT CONTAINS PROPRIETARY AND CONFIDENTIAL INFORMATION. IT IS THE PROPERTY OF TELEDYNE INSTRUMENTS AND IS NOT TO BE REPRODUCED, COPIED, OR TRANSMITTED IN ANY FORM OR BY ANY MEANS WITHOUT THE WRITTEN CONSENT OF TELEDYNE INSTRUMENTS.	
0 TO 4 41/32	.005	-02	UF150	TITLE	
4 TO 8 41/32	.008			ULTRAFLOW 150	
8 AND UP 41/32	.010			FLANGE INSTALLATION	
				(METRIC)	
AUTHORIZATION		MAT'L.		FINISH	
DRAWN	EAS 10-8-01				
CHECKED	EAS Mar-02				
DESIGNED	EAS Oct-01				
ENGINEERED	ELM 4-2-02				
PRODUCTION	PD 4-2-02				
Q.A.	GRG 4/2/02				
SCALE		SHEET		DRAWING NO.	
NTS		2 of 2		D 1900-0001	
				LATEST REVISION	
				D	

REVISIONS

ZONE	SYM.	DESCRIPTION	DATE	APPD.
	A	PER DCN #1900-0002A	8-23-02	ELM
	B	PER DCN #1900-0002B	9-17-02	ELM
	C	PER DCN #1900-0002C	2-18-03	DMB
	D	PER DCN #1900-0002D	5-1-03	ELM
	E	NO CHANGE THIS SHEET	5-21-03	ELM
	F	NO CHANGE THIS SHEET	6-9-03	ELM
	G	PER DCN #1900-0002G	1-8-04	ELM
	H	NO CHANGE THIS SHEET	5-19-09	ELM

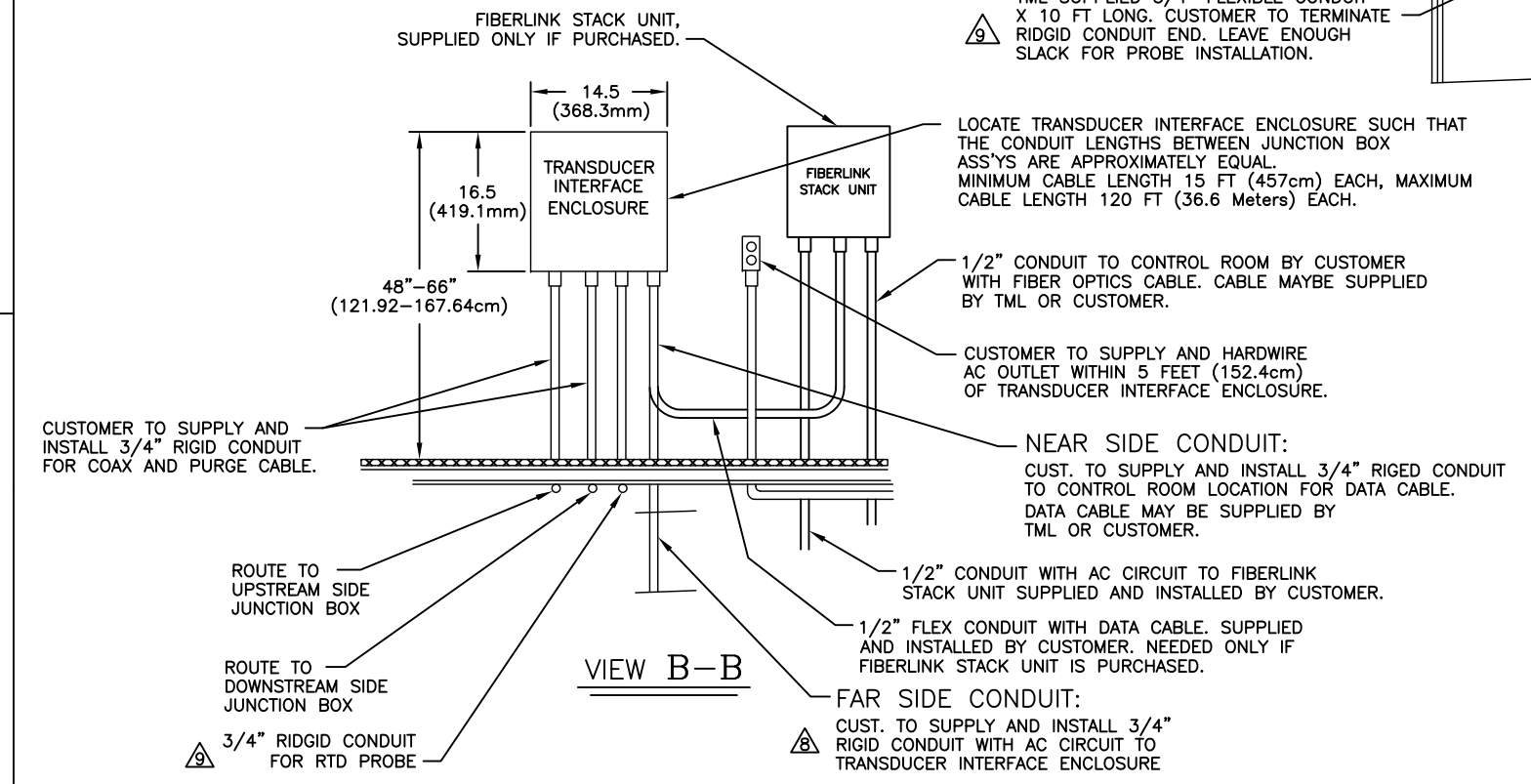
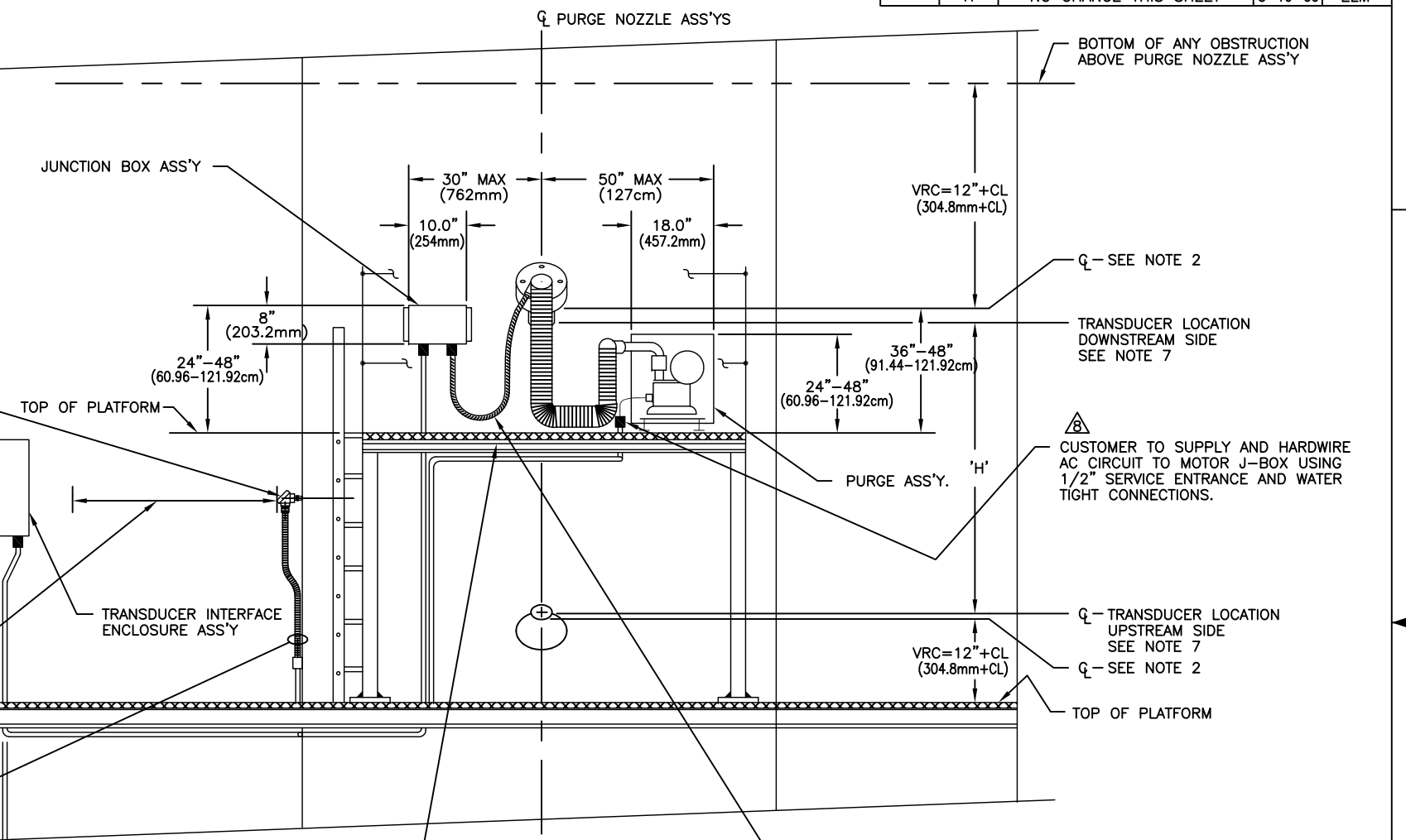
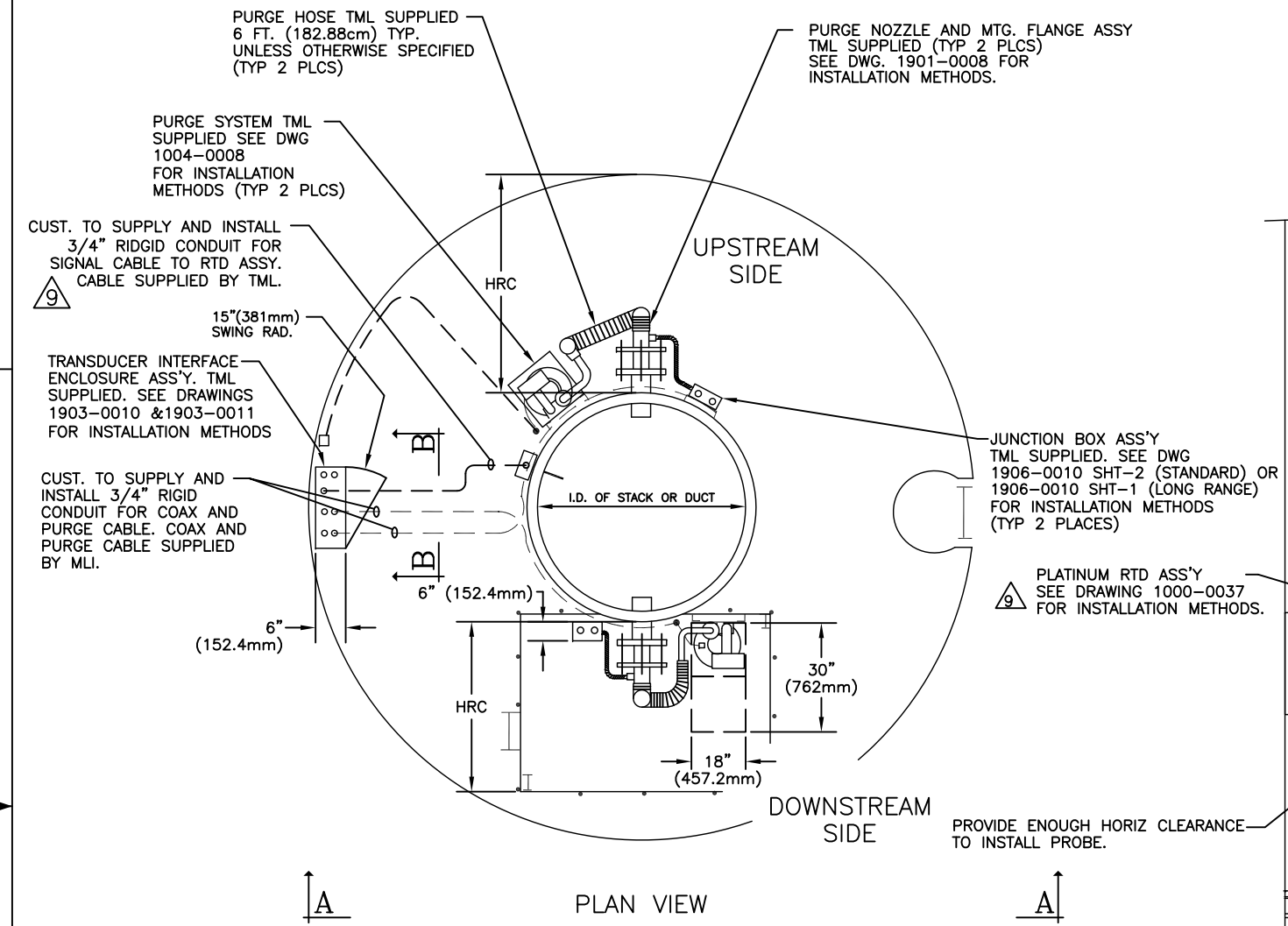

VIEW A-A

TML SUPPLIED 3/4" FLEXIBLE CONDUIT FOR COAX AND PURGE CABLE. COAX AND PURGE CABLE SUPPLIED BY MLI. MLI WILL SUPPLY WATER TIGHT CONNECTIONS FOR FLEXIBLE CONDUIT. CONDUIT IS TYPICALLY 6 FEET (183cm) UNLESS OTHERWISE SPECIFIED. (TYP 2 PLCS)

VIEW B-B

LOCATE TRANSDUCER INTERFACE ENCLOSURE SUCH THAT THE CONDUIT LENGTHS BETWEEN JUNCTION BOX ASS'YS ARE APPROXIMATELY EQUAL. MINIMUM CABLE LENGTH 15 FT (457cm) EACH, MAXIMUM CABLE LENGTH 120 FT (36.6 Meters) EACH.

1/2" CONDUIT TO CONTROL ROOM BY CUSTOMER WITH FIBER OPTICS CABLE. CABLE MAYBE SUPPLIED BY TML OR CUSTOMER.

CUSTOMER TO SUPPLY AND HARDWIRE AC OUTLET WITHIN 5 FEET (152.4cm) OF TRANSDUCER INTERFACE ENCLOSURE.

NEAR SIDE CONDUIT: CUST. TO SUPPLY AND INSTALL 3/4" RIDGED CONDUIT TO CONTROL ROOM LOCATION FOR DATA CABLE. DATA CABLE MAY BE SUPPLIED BY TML OR CUSTOMER.

1/2" CONDUIT WITH AC CIRCUIT TO FIBERLINK STACK UNIT SUPPLIED AND INSTALLED BY CUSTOMER.

1/2" FLEX CONDUIT WITH DATA CABLE. SUPPLIED AND INSTALLED BY CUSTOMER. NEEDED ONLY IF FIBERLINK STACK UNIT IS PURCHASED.

FAR SIDE CONDUIT: CUST. TO SUPPLY AND INSTALL 3/4" RIDGED CONDUIT WITH AC CIRCUIT TO TRANSDUCER INTERFACE ENCLOSURE

3/4" RIDGID CONDUIT FOR RTD PROBE

RTD IS USED FOR EXTERNAL TEMP. INPUT OPTION ONLY.

SEE DRAWING 1900-0004 FOR SYSTEM WIRING.

7 SEE DWG 1900-0001 FOR EXACT LOCATION OF TRANSDUCERS

6 CUST. TO SUPPLY AND INSTALL ALL RIDGID CONDUIT USING WATER TIGHT CONNECTORS.

5 CUST. MUST PROVIDE SAFE ACCESS PLATFORMS, CATWALKS, LADDERS, AND PROVIDE PROPER LIGHTING TO EACH PURGE NOZZLE ASSEMBLY FOR INSTALLATION PERSONNEL.

4 ALL DIMENSIONS ARE MINIMUM UNLESS OTHERWISE NOTED.

3 ALL DIMENSIONS IN () ARE METRIC.

2 CLEARANCE DIMENSIONAL DESCRIPTIONS:

HRC = MINIMUM HORIZONTAL CLEARANCE FROM THE PURGE NOZZLE ASSEMBLY TO RAILINGS OR OTHER OBSTRUCTION.

VRC=CL+12" (CL+304.8mm) = FOR THE UPSTREAM TRANSDUCER THIS REFERS TO THE MINIMUM VERTICAL CLEARANCE REQUIRED FROM THE BOTTOM JUNCTION OF THE MOUNTING TUBE AND STACK TO THE ACCESS CATWALK (OR ANY OTHER INTERVENING OBSTRUCTION). FOR THE DOWNSTREAM TRANSDUCER THIS REFERS TO THE MINIMUM VERTICAL CLEARANCE REQUIRED FROM THE TOP JUNCTION OF THE MOUNTING TUBE AND STACK TO THE NEAREST DOWNSTREAM OBSTRUCTION.

1 SEE DWG 1900-0001 FOR FLANGE INSTALLATION PROCEDURES AND TO DETERMINE 'H', 'CL' & 'HRC'

NOTES:

DUAL BLOWERS

TELEDYNE MONITOR LABS
A Teledyne Technologies Company

THIS DOCUMENT CONTAINS INFORMATION PROPRIETARY AND CONFIDENTIAL TO TELEDYNE MONITOR LABS AND IS FURNISHED UPON THE EXPRESS CONDITION THAT THE INFORMATION CONTAINED HEREIN WILL NOT BE REPRODUCED, DISCLOSED OR DISTRIBUTED TO OTHERS OR USED FOR ANY PURPOSE OTHER THAN IN CONNECTION WITH THE EVALUATION THEREOF WITHOUT THE PRIOR WRITTEN CONSENT OF TELEDYNE MONITOR LABS.

TITLE: **ULTRA FLOW 150 SYSTEM INSTALLATION**

FINISH

DIMENSIONAL TOLERANCES UNLESS OTHERWISE SPECIFIED		USED ON	
FRACTIONS	DECIMALS	DASH NO	NEXT ASSEMBLY
0 TO 4 ±1/32	.001	-01	UF150
4 TO 8 ±1/16	.005		
8 AND UP ±1/8			
ALL DIMENSIONS ARE IN INCHES DO NOT SCALE THIS DRAWING			
AUTHORIZATION			
DRAWN	EAS	DATE	10-19-01
CHECKED	EAS	DATE	Mar-02
DESIGNED	EAS	DATE	Oct-01
ENGINEERED	ELM	DATE	4-2-02
PRODUCTION	PD	DATE	4-2-02
Q.A.	GRG	DATE	4/2/02

SCALE: NTS SHEET: 1 of 6

DRAWING NO. **D 1900-0002** LATEST REVISION: **H**

ACAD FILE 19000002-MS

REVISIONS				
ZONE	SYM.	DESCRIPTION	DATE	APPD.
	A	PER DCN #1900-0002A	8-23-02	EAS
	B	PER DCN #1900-0002B	9-17-02	ELM
	C	PER DCN #1900-0002C	2-18-03	DMB
	D	PER DCN #1900-0002D	5-1-03	ELM
	E	NO CHANGE THIS SHEET	5-21-03	ELM
	F	NO CHANGE THIS SHEET	6-9-03	ELM
	G	PER DCN #1900-0002G	1-8-04	ELM
	H	NO CHANGE THIS SHEET	5-19-09	ELM

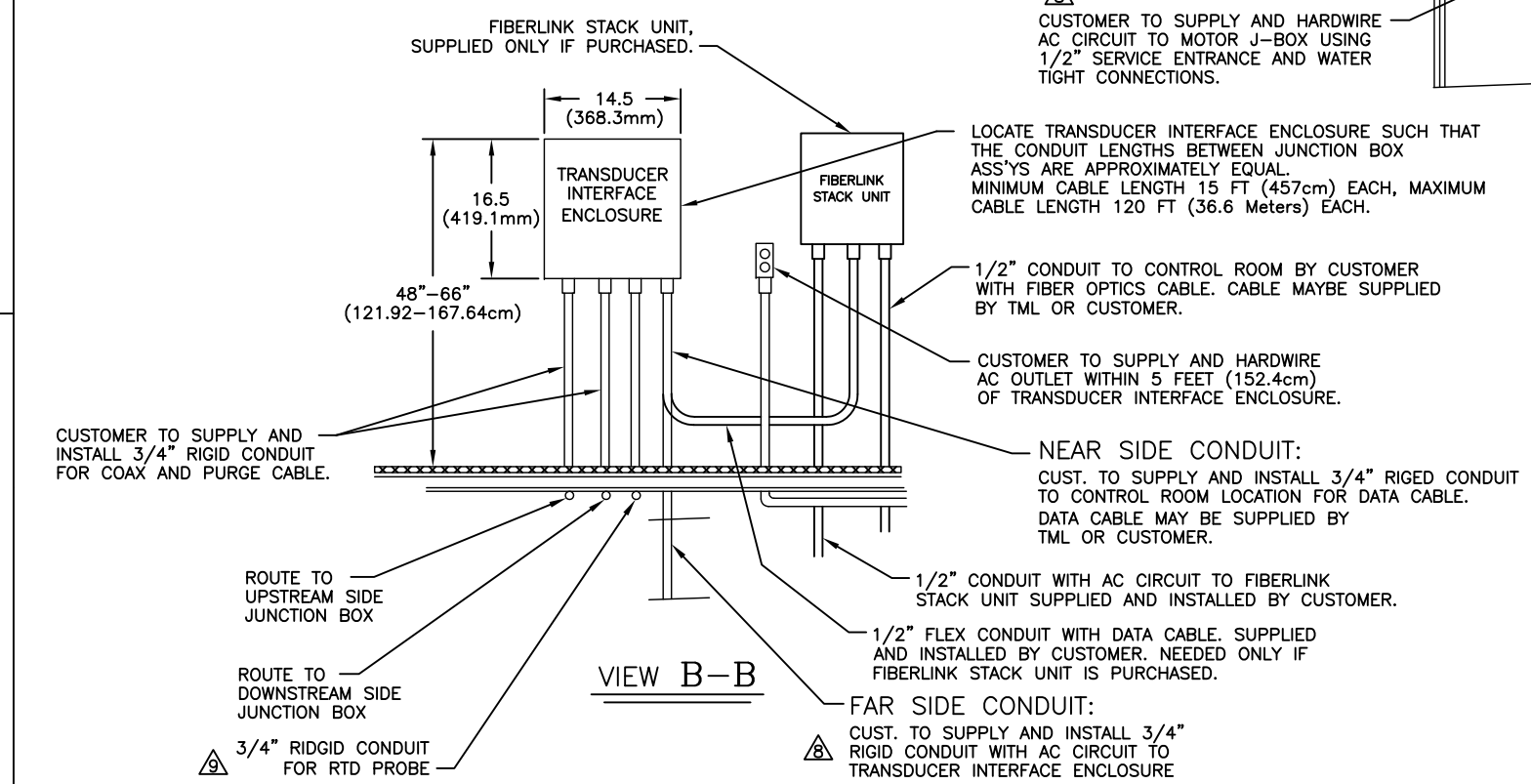
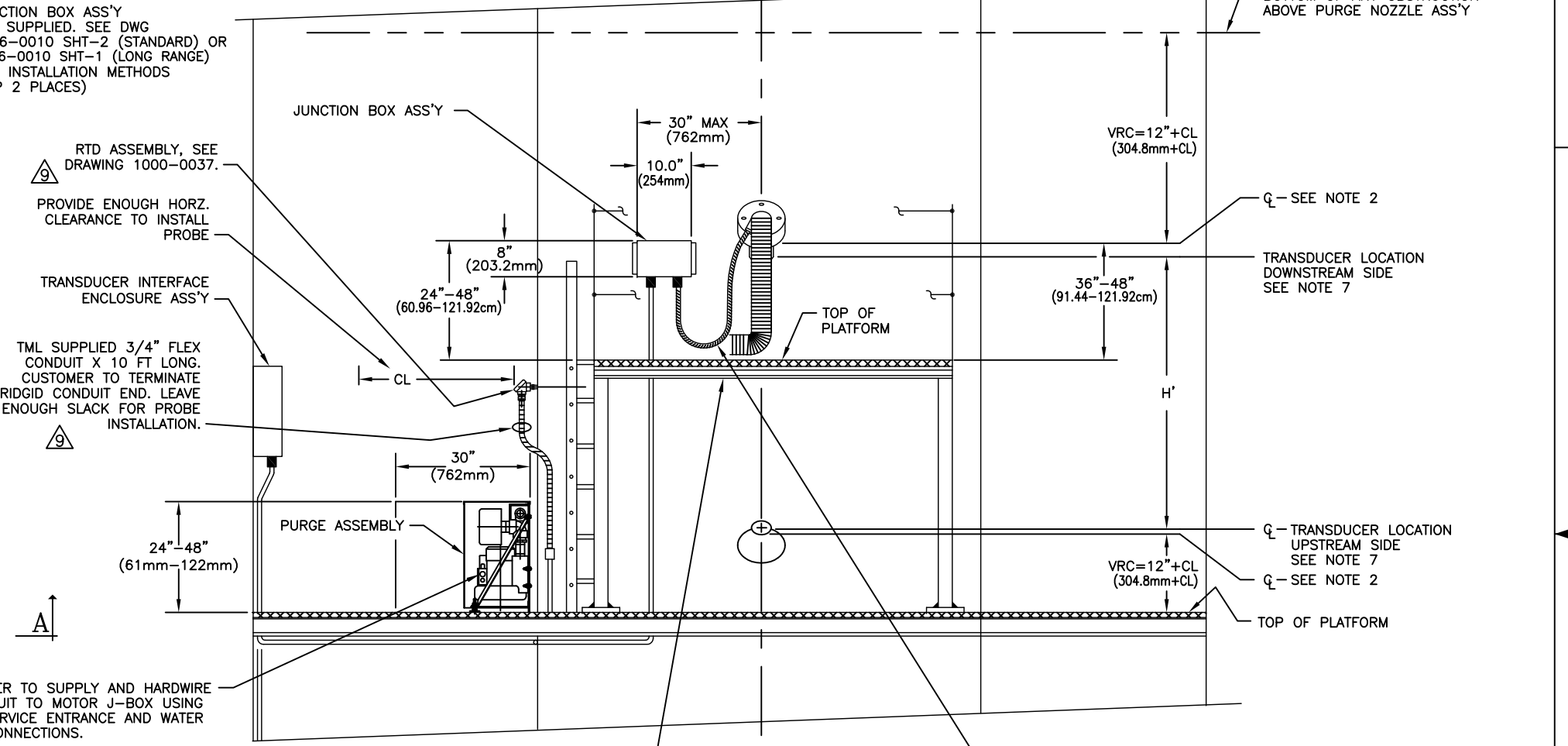
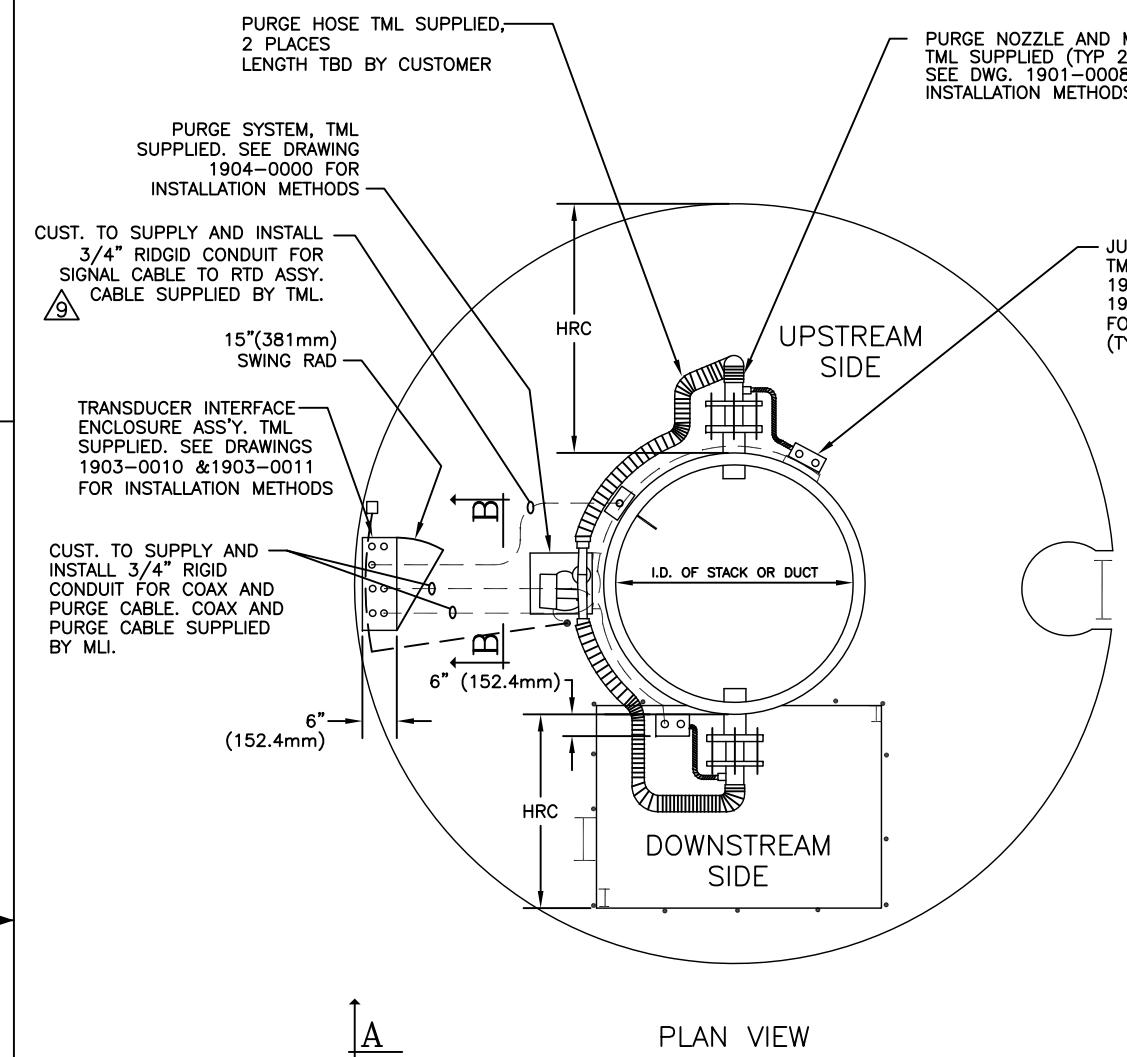

TML SUPPLIED 3/4" FLEXIBLE CONDUIT FOR COAX AND PURGE CABLE. COAX AND PURGE CABLE SUPPLIED BY MLI. MLI WILL SUPPLY WATER TIGHT CONNECTIONS FOR FLEXIBLE CONDUIT. CONDUIT IS TYPICALLY 6 FEET (183cm) UNLESS OTHERWISE SPECIFIED. (TYP 2 PLCS)

- NOTES:
- 1 SEE DWG 1900-0001 FOR FLANGE INSTALLATION PROCEDURES AND TO DETERMINE 'H', 'CL' & 'HRC'
 - 2 CLEARANCE DIMENSIONAL DESCRIPTIONS:
 HRC = MINIMUM HORIZONTAL CLEARANCE FROM THE PURGE NOZZLE ASSEMBLY TO RAILINGS OR OTHER OBSTRUCTION.
 VRC=CL+12" (CL+304.8mm) = FOR THE UPSTREAM TRANSUCER THIS REFERS TO THE MINIMUM VERTICAL CLEARANCE REQUIRED FROM THE BOTTOM JUNCTION OF THE MOUNTING TUBE AND STACK TO THE ACCESS CATWALK (OR ANY OTHER INTERVENING OBSTRUCTION). FOR THE DOWNSTREAM TRANSUCER THIS REFERS TO THE MINIMUM VERTICAL CLEARANCE REQUIRED FROM THE TOP JUNCTION OF THE MOUNTING TUBE AND STACK TO THE NEAREST DOWNSTREAM OBSTRUCTION.
 - 3 ALL DIMENSIONS IN () ARE METRIC.
 - 4 ALL DIMENSIONS ARE MINIMUM UNLESS OTHERWISE NOTED.
 - 5 CUST. MUST PROVIDE SAFE ACCESS PLATFORMS, CATWALKS, LADDERS, AND PROVIDE PROPER LIGHTING TO EACH PURGE NOZZLE ASSEMBLY FOR INSTALLATION PERSONNEL.
 - 6 CUST. TO SUPPLY AND INSTALL ALL RIGID CONDUIT USING WATER TIGHT CONNECTORS.
 - 7 SEE DWG 1900-0001 FOR EXACT LOCATION OF TRANSUCERS

SINGLE BLOWER

DIMENSIONAL TOLERANCES UNLESS OTHERWISE SPECIFIED		USED ON		<p>TELEDYNE MONITOR LABS A Teledyne Technologies Company</p> <p>THIS DOCUMENT CONTAINS INFORMATION PROPRIETARY AND CONFIDENTIAL TO TELEMONITOR LABS AND IS FURNISHED UPON THE EXPRESS CONDITION THAT THE INFORMATION CONTAINED HEREIN WILL NOT BE REPRODUCED, DISCLOSED OR DISSEMINATED TO OTHERS OR USED FOR ANY PURPOSE OTHER THAN IN CONNECTION WITH THE EVALUATION THEREOF WITHOUT THE PRIOR WRITTEN CONSENT OF TELEMONITOR LABS.</p>
FRACTIONS 9 TO 4 ±1/32	DECIMALS XXX ±.01	ANGLES 30°/3'	DASH NO NEXT ASSEMBLY -02 UF150	
ALL DIMENSIONS ARE IN INCHES DO NOT SCALE THIS DRAWING				
AUTHORIZATION				
DRAWN	EAS	DATE	10-26-01	
CHECKED	EAS	DATE	Mar-02	
DESIGNED	EAS	DATE	Oct-01	
ENGINEERED	ELM	DATE	4-2-02	
PRODUCTION	PD	DATE	4-2-02	
Q.A.	GRG	DATE	4/2/02	
SCALE		SHEET		
NTS		2 OF 6		
DRAWING NO.		LATEST REVISION		
D 1900-0002		H		

REVISIONS				
ZONE	SYM.	DESCRIPTION	DATE	APPD.
	A	PER DCN #1900-0002A	8-23-02	ELM
	B	NO CHANGE THIS SHEET	9-17-02	ELM
	C	PER DCN #1900-0002C	2-18-03	DMB
	D	PER DCN #1900-0002D	5-1-03	ELM
	E	NO CHANGE THIS SHEET	5-21-03	ELM
	F	NO CHANGE THIS SHEET	6-9-03	ELM
	G	NO CHANGE THIS SHEET	1-8-04	ELM
	H	NO CHANGE THIS SHEET	5-19-09	ELM

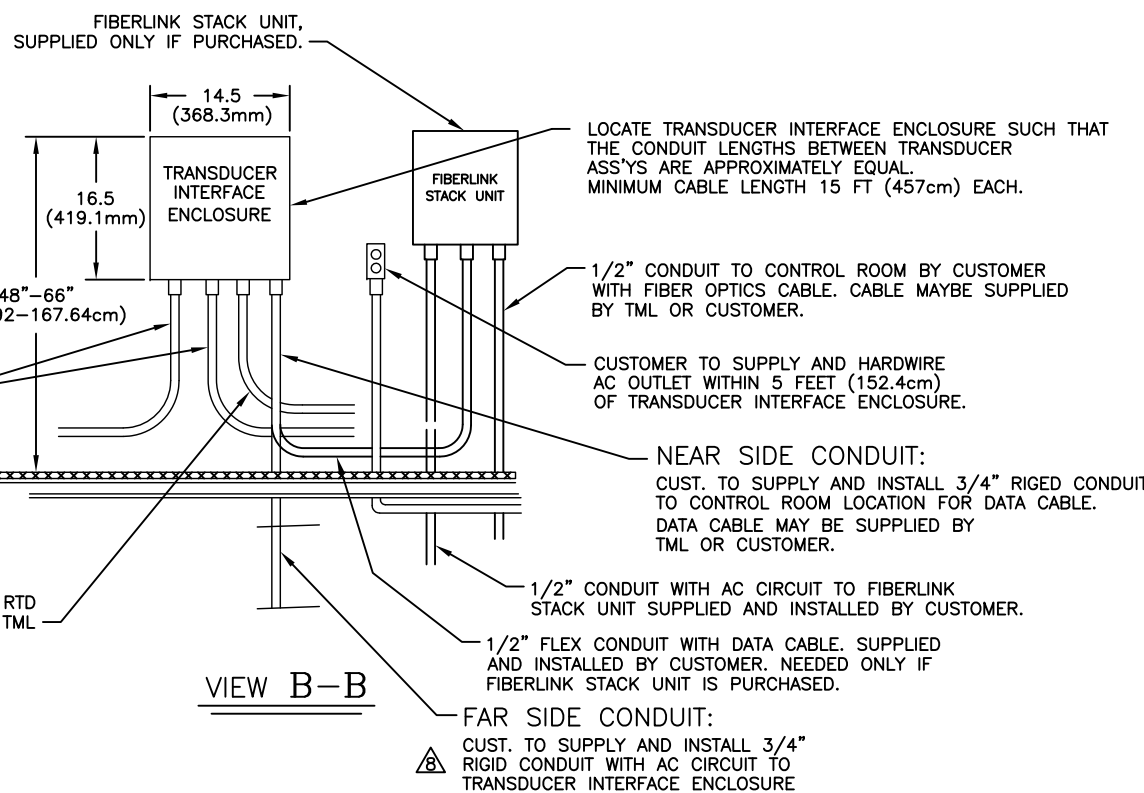
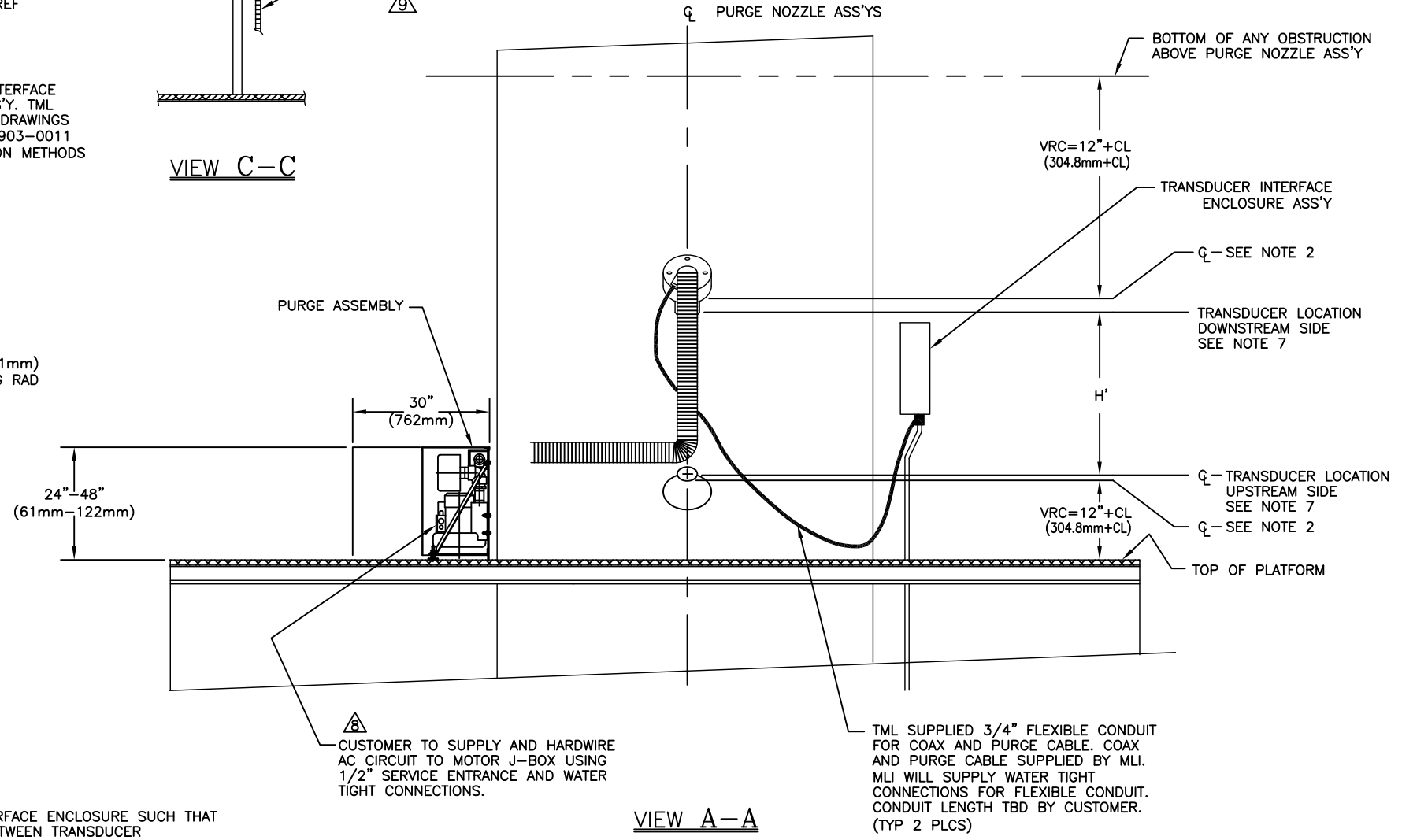
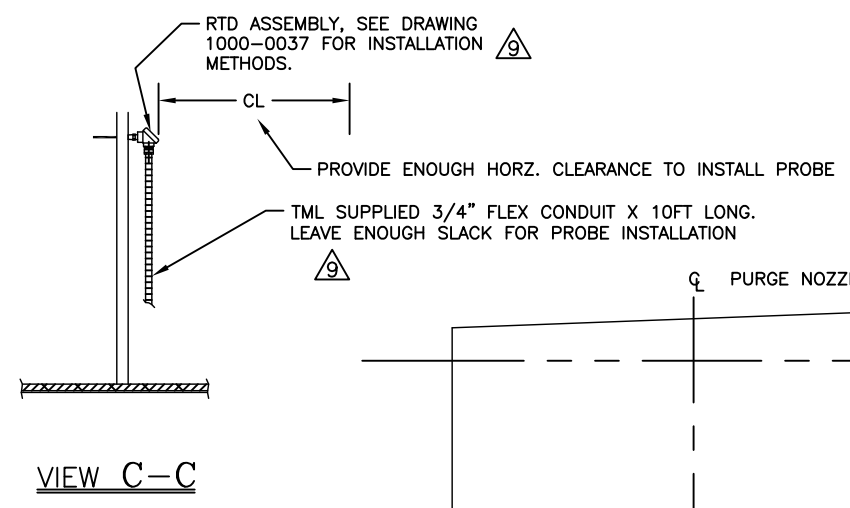
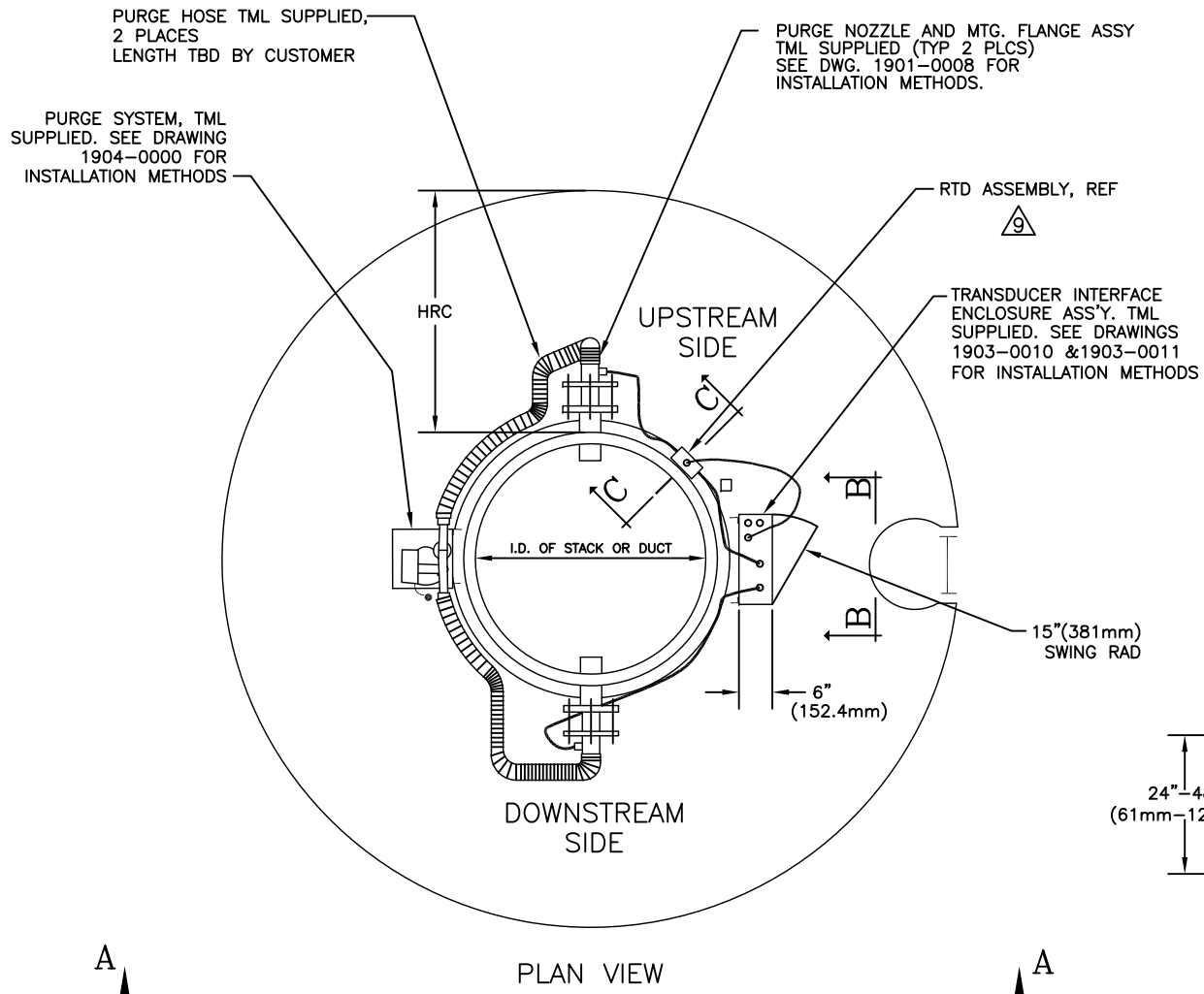

- ⚠ RTD IS USED FOR EXTERNAL TEMP. INPUT OPTION ONLY.
- ⚠ SEE DRAWING 1900-0004 FOR SYSTEM WIRING.
- 7 SEE DWG 1900-0001 FOR EXACT LOCATION OF TRANSUCERS
- 6 CUST. TO SUPPLY AND INSTALL ALL RIGID CONDUIT USING WATER TIGHT CONNECTORS.
- 5 CUST. MUST PROVIDE SAFE ACCESS PLATFORMS, CATWALKS, LADDERS, AND PROVIDE PROPER LIGHTING TO EACH PURGE NOZZLE ASSEMBLY FOR INSTALLATION PERSONNEL.
- 4 ALL DIMENSIONS ARE MINIMUM UNLESS OTHERWISE NOTED.
- 3 ALL DIMENSIONS IN () ARE METRIC.
- 2 CLEARANCE DIMENSIONAL DESCRIPTIONS:
 - HRC = MINIMUM HORIZONTAL CLEARANCE FROM THE PURGE NOZZLE ASSEMBLY TO RAILINGS OR OTHER OBSTRUCTION.
 - VRC=CL+12" (CL+304.8mm) = FOR THE UPSTREAM TRANSUCER THIS REFERS TO THE MINIMUM VERTICAL CLEARANCE REQUIRED FROM THE BOTTOM JUNCTION OF THE MOUNTING TUBE AND STACK TO THE ACCESS CATWALK (OR ANY OTHER INTERVENING OBSTRUCTION). FOR THE DOWNSTREAM TRANSUCER THIS REFERS TO THE MINIMUM VERTICAL CLEARANCE REQUIRED FROM THE TOP JUNCTION OF THE MOUNTING TUBE AND STACK TO THE NEAREST DOWNSTREAM OBSTRUCTION.
- 1 SEE DWG 1900-0001 FOR FLANGE INSTALLATION PROCEDURES AND TO DETERMINE 'H', 'CL' & 'HRC'

TML SUPPLIED 3/4" FLEXIBLE CONDUIT FOR COAX AND PURGE CABLE. COAX AND PURGE CABLE SUPPLIED BY MLI. MLI WILL SUPPLY WATER TIGHT CONNECTIONS FOR FLEXIBLE CONDUIT. CONDUIT LENGTH TBD BY CUSTOMER. (TYP 2 PLCS)

SINGLE BLOWER NO JUNCTION BOX'S FOR STACK DIAMETERS <8 FT(2.44M).

DIMENSIONAL TOLERANCES UNLESS OTHERWISE SPECIFIED		USED ON		TELEDYNE MONITOR LABS A Teledyne Technologies Company	
FRACTIONS 0 TO 4 ±1/32	DECIMALS JOK ±.01	ANGLES 30°/3'	DASH NO	NEXT ASSEMBLY	THIS DOCUMENT CONTAINS INFORMATION PROPRIETARY AND CONFIDENTIAL TO TELEDYNE MONITOR LABS AND IS FURNISHED UPON THE EXPRESS CONDITION THAT THE INFORMATION CONTAINED HEREIN WILL NOT BE REPRODUCED, DISCLOSED OR DISSEMINATED TO OTHERS OR USED FOR ANY PURPOSE OTHER THAN IN CONNECTION WITH THE EVALUATION THEREOF WITHOUT THE PRIOR WRITTEN CONSENT OF TELEDYNE MONITOR LABS.
4 TO 8 ±1/16	JOK ±.005	RMS FINISH	-03	UF150	
TITLE ULTRA FLOW 150 SYSTEM INSTALLATION					
AUTHORIZATION		SCALE		SHEET	
DRAWN	EAS 2-28-02	MAT'L.	FINISH		DRAWING NO. D 1900-0002
CHECKED	EAS Mar-02	JIG NO.	LATEST REVISION		
DESIGNED	EAS Feb-02	SCALE	3 of 6		
ENGINEERED	ELM 4-2-02	NTS	H		
PRODUCTION	PD 4-2-02	ACAD FILE 19000002-MS			
Q.A.	GRG 4/2/02	1 5-19-09			

NOTES:

REVISIONS				
ZONE	SYM.	DESCRIPTION	DATE	APPD.
	B	PER DCN #1900-0002B	9-17-02	ELM
	C	PER DCN #1900-0002C	2-18-03	DMB
	D	PER DCN #1900-0002D	5-1-03	ELM
	E	NO CHANGE THIS SHEET	5-21-03	ELM
	F	NO CHANGE THIS SHEET	6-9-03	ELM
	G	PER DCN #1900-0002G	1-8-04	ELM
	H	NO CHANGE THIS SHEET	5-19-09	ELM

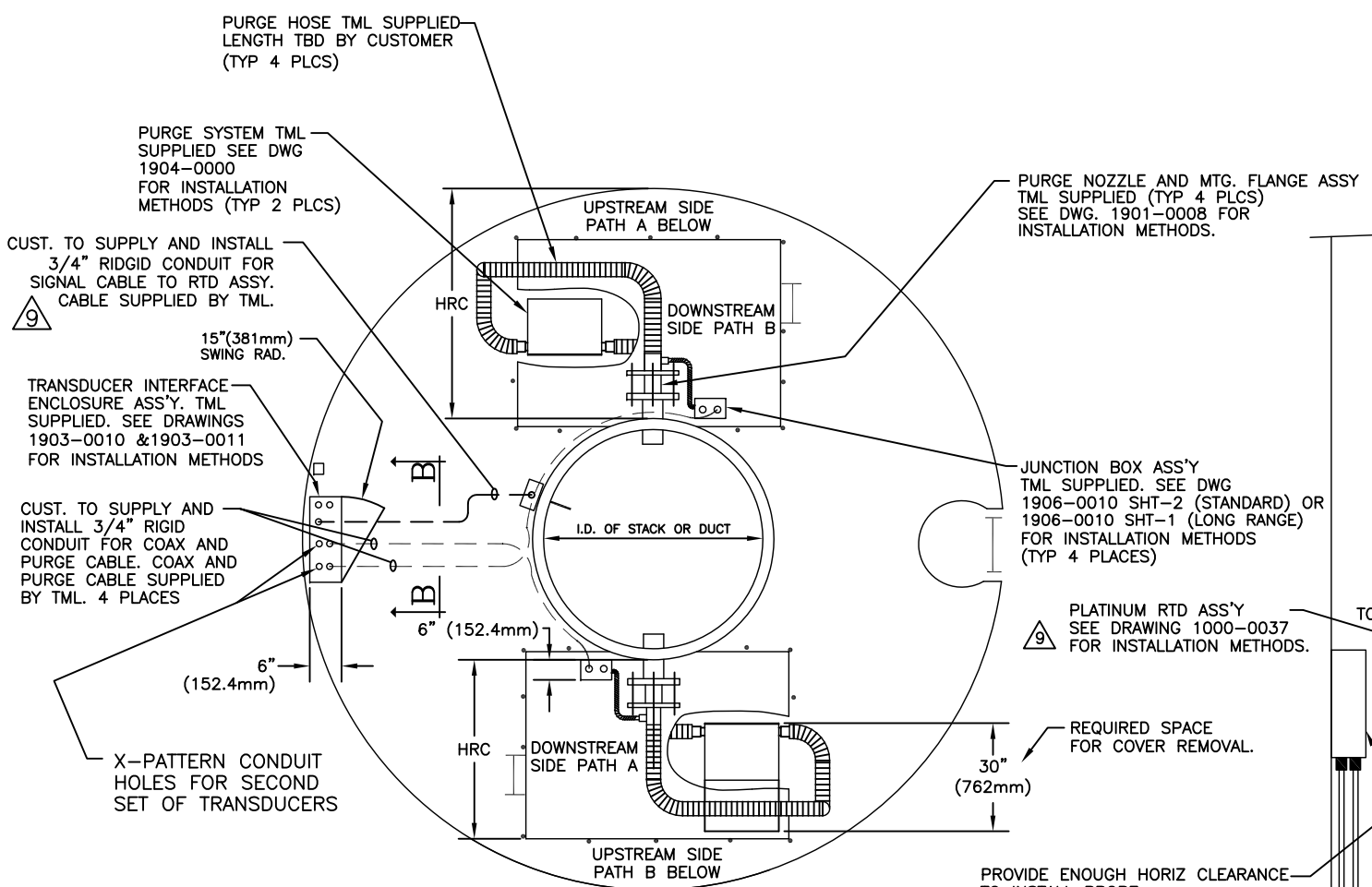

PLAN VIEW

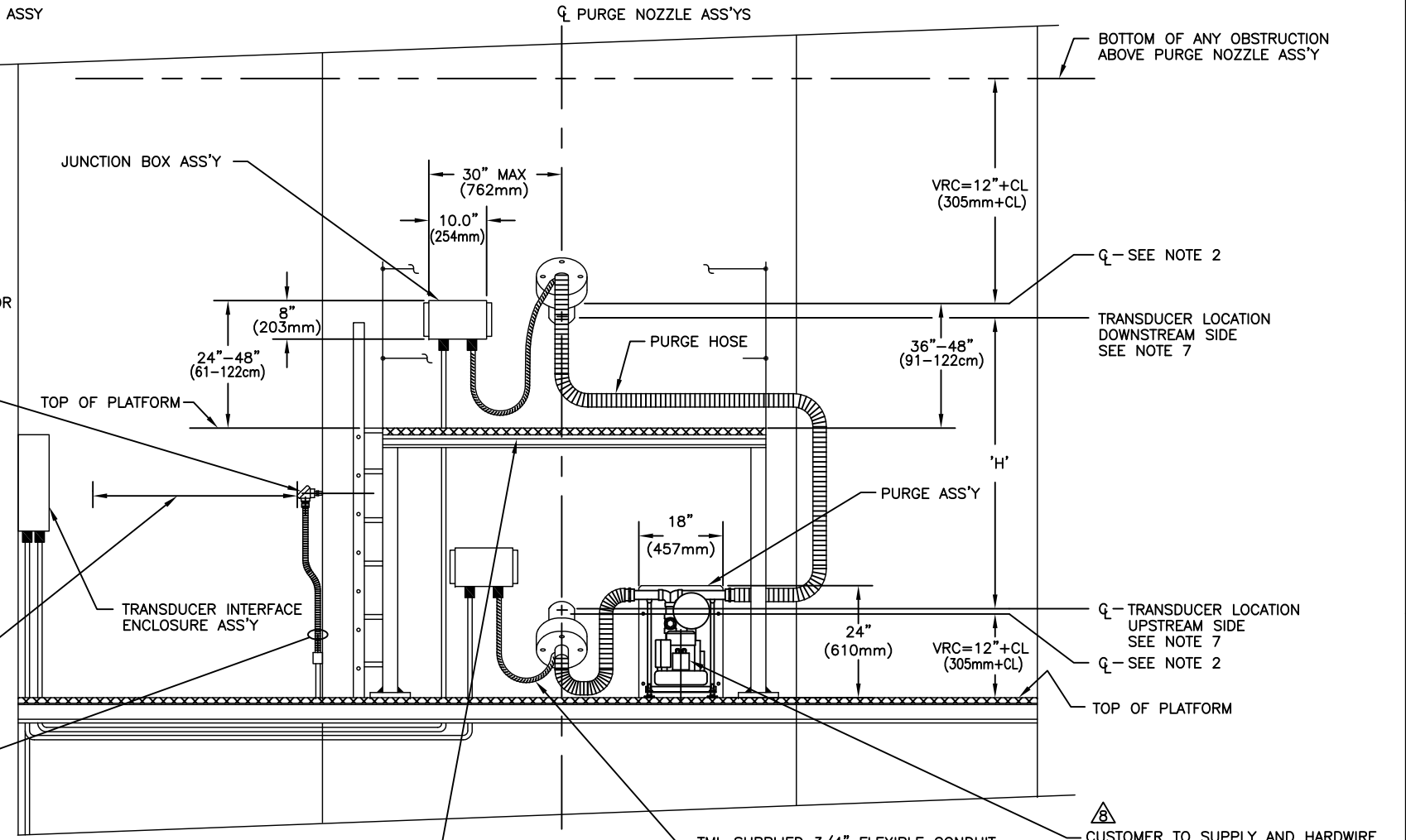

VIEW A-A

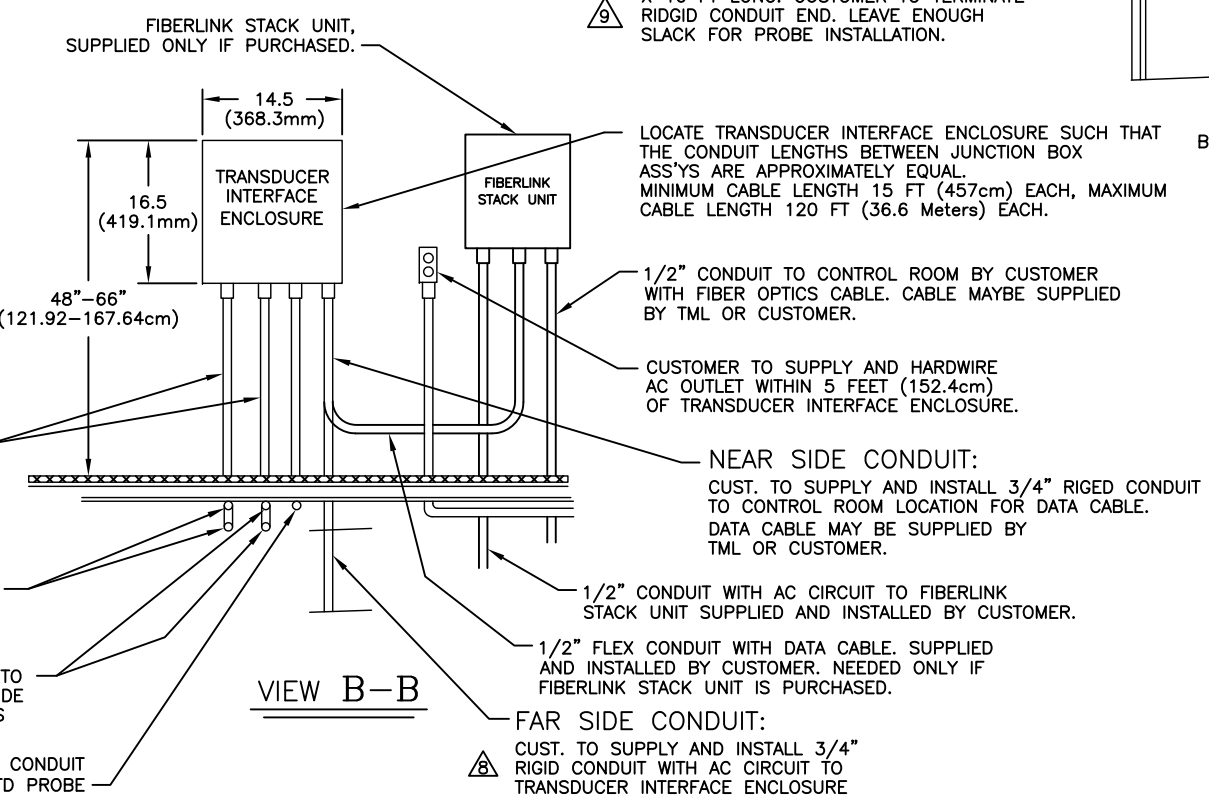

VIEW B-B

- NOTES:
- 1 SEE DWG 1900-0001 & 1900-0006 FOR FLANGE INSTALLATION PROCEDURES AND TO DETERMINE 'H', 'CL' & 'HRC'
 - 2 CLEARANCE DIMENSIONAL DESCRIPTIONS:
 - HRC = MINIMUM HORIZONTAL CLEARANCE FROM THE PURGE NOZZLE ASSEMBLY TO RAILINGS OR OTHER OBSTRUCTION.
 - VRC=CL+12" (CL+305mm) = FOR THE UPSTREAM TRANSDUCER THIS REFERS TO THE MINIMUM VERTICAL CLEARANCE REQUIRED FROM THE BOTTOM JUNCTION OF THE MOUNTING TUBE AND STACK TO THE ACCESS CATWALK (OR ANY OTHER INTERVENING OBSTRUCTION). FOR THE DOWNSTREAM TRANSDUCER THIS REFERS TO THE MINIMUM VERTICAL CLEARANCE REQUIRED FROM THE TOP JUNCTION OF THE MOUNTING TUBE AND STACK TO THE NEAREST DOWNSTREAM OBSTRUCTION.
 - 3 ALL DIMENSIONS IN () ARE METRIC.
 - 4 ALL DIMENSIONS ARE MINIMUM UNLESS OTHERWISE NOTED.
 - 5 CUST. MUST PROVIDE SAFE ACCESS PLATFORMS, CATWALKS, LADDERS, AND PROVIDE PROPER LIGHTING TO EACH PURGE NOZZLE ASSEMBLY FOR INSTALLATION PERSONNEL.
 - 6 CUST. TO SUPPLY AND INSTALL ALL RIGID CONDUIT USING WATER TIGHT CONNECTORS.
 - 7 SEE DWG 1900-0001/1900-0006 FOR EXACT LOCATION OF TRANSDUCERS
 - 8 SEE DRAWING 1900-0004 FOR SYSTEM WIRING.
 - 9 RTD IS USED FOR EXTERNAL TEMP. INPUT OPTION ONLY.

DIMENSIONAL TOLERANCES UNLESS OTHERWISE SPECIFIED		USED ON		TELEDYNE MONITOR LABS A Teledyne Technologies Company	
FRACTIONS	DECIMALS	ANGLES	DASH NO	NEXT ASSEMBLY	THIS DOCUMENT CONTAINS INFORMATION PROPRIETARY AND CONFIDENTIAL TO TELEDYNE MONITOR LABS AND IS FURNISHED UPON THE EXPRESS CONDITION THAT THE INFORMATION CONTAINED HEREIN WILL NOT BE REPRODUCED, DISCLOSED OR DISTRIBUTED TO OTHERS OR USED FOR ANY PURPOSE OTHER THAN IN CONNECTION WITH THE EVALUATION THEREOF WITHOUT THE PRIOR WRITTEN CONSENT OF TELEDYNE MONITOR LABS.
9 TO 4 ±1/32	.XX ±.01	30°	-04	UF150	
4 TO 8 ±1/16	.XX ±.005	RMS FINISH			TITLE
B AND UP ±1/8					ULTRA FLOW 150 SYSTEM INSTALLATION
ALL DIMENSIONS ARE IN INCHES DO NOT SCALE THIS DRAWING					
AUTHORIZATION		SCALE		SHEET	
DRAWN	EAS	9-17-02	MAT'L.	FINISH	
CHECKED	EAS	Sept-02	JIG NO.		
DESIGNED	EAS	Sept-02	SCALE	4 of 6	
ENGINEERED	ELM	9-20-02			
PRODUCTION	PD	9-25-02			
Q.A.	AS	9-25-02			

X-PATTERN DUAL 110cfm BLOWERS

DRAWING NO.	1900-0002	LATEST REVISION	H
-------------	-----------	-----------------	---

REVISIONS

ZONE	SYM.	DESCRIPTION	DATE	APPD.
A		PER DCN #1900-0004A	7-1-02	ELM
B		NO CHANGE THIS SHEET	9-20-02	ELM
C		PER DCN 1900-0004C	4-22-03	ELM
D		PER DCN 1900-0004D	11-19-03	DMB
E		PER DCN 1900-0004E	6-1-07	ELM
F		NO CHANGE THIS SHEET	10-10-13	I.E.

⚠ MAINTENANCE PROCEDURES REQUIRING THE REMOVAL OF THE COVER ARE INTENDED TO BE PERFORMED BY TRAINED PERSONNEL ONLY. CONSULT MANUAL.

⚠ ALL FIELD WIRING TERMINATED ON STACK MOUNTED EQUIPMENT TO BE RATED MINIMUM 75 DEGREES C.

⚠ IF LINK ROD OPTION IS PROVIDED, DUAL BLOWERS OF THE HIGHER CFM RATING (SBI) MAY BE REQUIRED, AND PROTECTIVE DISCONNECT DEVICES SHOULD BE CHOSEN ACCORDINGLY. CONTACT TML FOR ALL CIRCUIT BREAKER RECOMMENDATIONS.

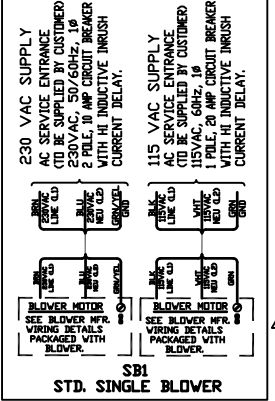

- ⚠ CUSTOMER TO PROVIDE CIRCUIT BREAKERS OF APPROPRIATE RATING AT SAME ELEVATION AS TML EQUIPMENT BEING SUPPLIED. LABEL DISC. DEVICES WITH NAME/TAG NO. OF EACH DEVICE BEING SUPPLIED. CONTACT TML FOR RECOMMENDED BREAKERS.
- ⚠ SYSTEMS MAY BE PROVIDED WITH ONE BLOWER 'SBI' OR DUAL BLOWERS, 'DB1 & DB2'. THE SIZE AND QUANTITY OF BLOWERS ARE DETERMINED BY TML BASED ON THE SPECIFICATIONS AND CONDITIONS OF EACH INDIVIDUAL STACK. SEE NOTE 11.
- ⚠ IF FIBRELINK III OPTION IS PROVIDED, CONNECT CONTROL UNITS AND DATA CABLES PER TML SUPPLEMENTAL WIRING DIAGRAM 1808-0003, SHT. 4 AND 1808-0007.
- ⚠ SEE 'REAR PANEL I/O TABLE' FOR WIRE TERMINATIONS.
- ⚠ RECOMMENDED STACK NETWORK CABLE IS 'SHIELDED'. SHIELDS MUST BE TERMINATED AS SHOWN AND WITH TERMINATOR (0650-0400-01) AT THE TIE BOX. IN NO INSTALLATION SHALL DATA CABLE BE RUN IN TRAYS OR CONDUIT WITH OTHER CABLES EXCEEDING 230 VAC.
- ⚠ TERMINATE WIRES TO REAR PANEL USING CAGE CLAMP STYLE CONNECTORS FROM KIT PROVIDED.
- ⚠ ALL CUSTOMER CONNECTIONS TO ANALOG OUTPUTS MUST BE THRU TWISTED PAIR SHIELDED CABLES. ALL SUCH SHIELDS SHALL TERMINATE AT J4-3; J4-6; J3-3; J3-6 FOR OUTPUTS 1 THRU 4 RESPECTIVELY.

NOTES: ⚠ TERMINATED AT SITE DURING FINAL INSTALLATION.

DIMENSIONAL TOLERANCES UNLESS OTHERWISE SPECIFIED		USED IN		TELEDYNE MONITOR LABS Everywhere you look	
FRACTION	TOLERANCE	DRAWN	DATE	TITLE ULTRA FLOW 150 STD. WIRING DIAGRAM (115/230 VAC)	
DECIMAL	TOLERANCE	CHECKED	DATE		
ANGLE	TOLERANCE	DESIGNED	DATE		
ALL DIMENSIONS ARE IN INCHES UNLESS OTHERWISE SPECIFIED		ENGINEERED	DATE		
DASH NEXT ASSEMBLY 1900-0000		PRODUCTION	DATE	FINISH	
AUTHORIZATION		BY	DATE	DRAWING NO.	
		DATE	DATE	1900-0004	
		DATE	DATE	LAYER	
		DATE	DATE	F	
		DATE	DATE	SCALE	
		DATE	DATE	1:12	
		DATE	DATE	SHEET	
		DATE	DATE	1 of 12	

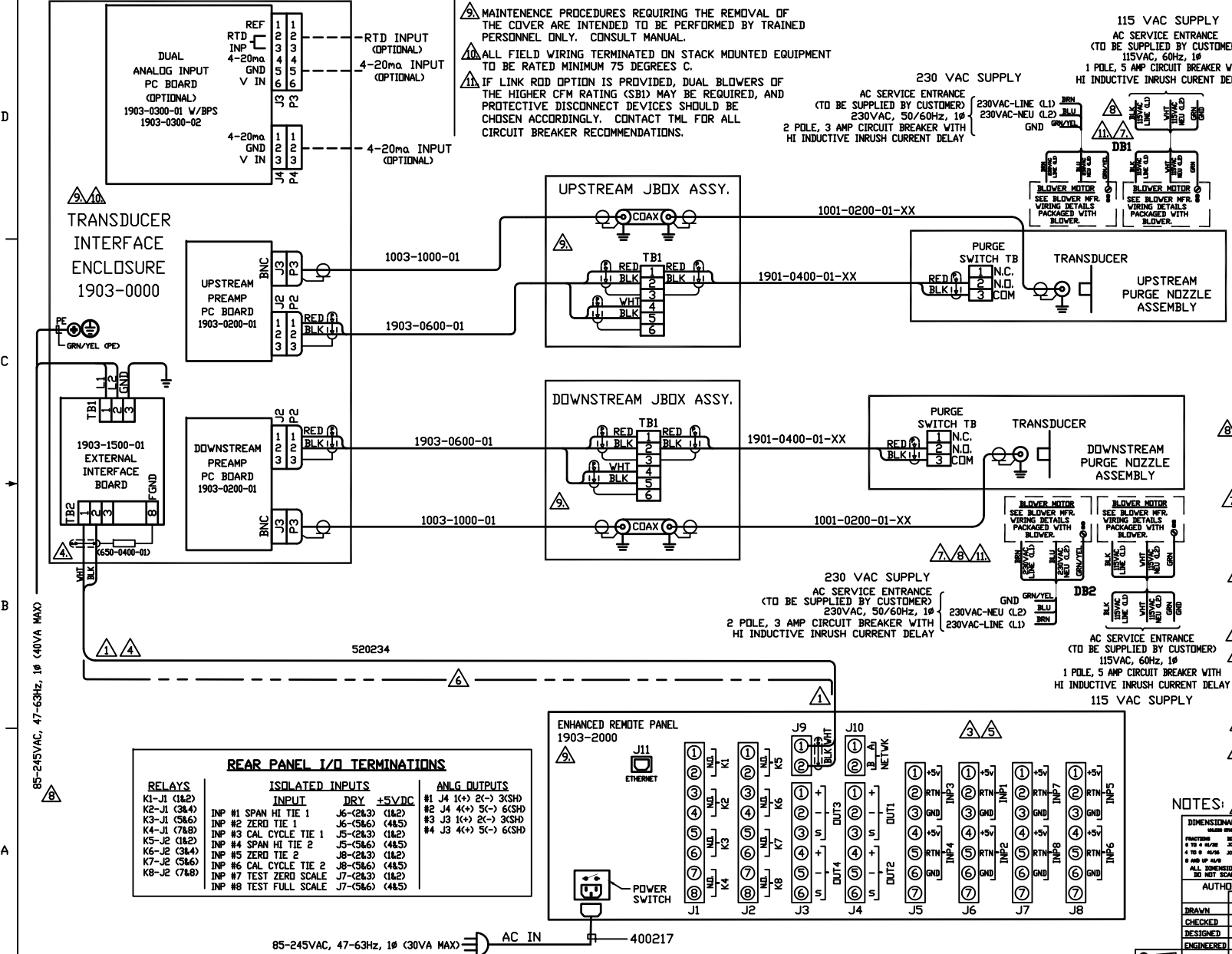

REAR PANEL I/O TERMINATIONS

RELAYS	ISOLATED INPUTS	ANLG OUTPUTS
K1-J1 (1&2)	INPUT DRY ±5VDC	#1 J4 I(+) 2(-) 3(SH)
K2-J1 (3&4)	INP #1 SPAN HI TIE 1 J6-(2&3) (1&2)	#2 J4 4(+) 5(-) 6(SH)
K3-J1 (5&6)	INP #2 ZERO TIE 1 J6-(5&6) (4&5)	#3 J3 I(+) 2(-) 3(SH)
K4-J1 (7&8)	INP #3 CAL CYCLE TIE 1 J5-(2&3) (1&2)	#4 J3 4(+) 5(-) 6(SH)
K5-J2 (1&2)	INP #4 SPAN HI TIE 2 J5-(5&6) (4&5)	
K6-J2 (3&4)	INP #5 ZERO TIE 2 J8-(2&3) (1&2)	
K7-J2 (5&6)	INP #6 CAL CYCLE TIE 2 J8-(5&6) (4&5)	
K8-J2 (7&8)	INP #7 TEST ZERO SCALE J7-(2&3) (1&2)	
	INP #8 TEST FULL SCALE J7-(5&6) (4&5)	

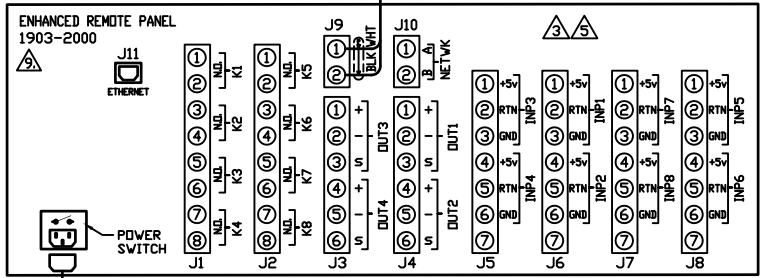

REVISIONS					
ZONE	SYM.	DESCRIPTION	DATE	APPD.	
A		ADDED THIS SHEET PER DCN #1900-0004A	7-1-02	ELM	
B		NO CHANGE THIS SHEET	9-20-02	ELM	
C		NO CHANGE THIS SHEET	5-13-03	ELM	
D		NO CHANGE THIS SHEET	11-20-03	ELM	
E		PER DCN 1900-0004E	6-1-07	ELM	
F		NO CHANGE THIS SHEET	10-10-13	I.E.	

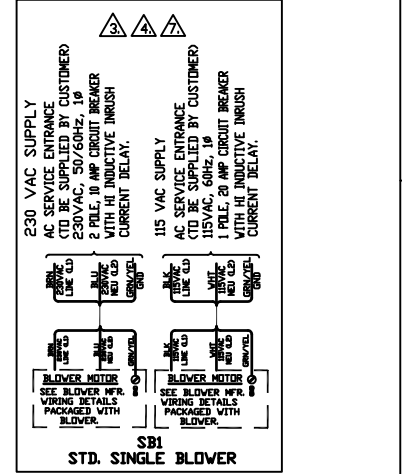

- IF LINK ROD OPTION IS PROVIDED, DUAL BLOWERS OF THE HIGHER CFM RATING (SBI) MAY BE REQUIRED, AND PROTECTIVE DISCONNECT DEVICES SHOULD BE CHOSEN ACCORDINGLY. CONTACT TML FOR ALL CIRCUIT BREAKER RECOMMENDATIONS.
- MAINTENANCE PROCEDURES REQUIRING THE REMOVAL OF THE COVER ARE INTENDED TO BE PERFORMED BY TRAINED PERSONNEL ONLY. CONSULT MANUAL.
- ALL FIELD WIRING TERMINATED ON STACK MOUNTED EQUIPMENT TO BE RATED MINIMUM 75 DEGREES C.
- CUSTOMER TO PROVIDE CIRCUIT BREAKER OF APPROPRIATE RATING AT SAME ELEVATION AS TML EQUIPMENT BEING SUPPLIED. LABEL EACH DISC. DEVICE WITH NAME/TAG NO. OF EACH DEVICE BEING SUPPLIED. SEE NOTE 7.
- SYSTEMS MAY BE PROVIDED WITH ONE BLOWER "SBI" OR DUAL BLOWERS, "DB1 & DB2". THE SIZE AND QUANTITY OF BLOWERS ARE DETERMINED BY TML BASED ON THE SPECIFICATIONS AND CONDITIONS OF EACH INDIVIDUAL STACK. SEE NOTE 7.
- RELAY CONTACTS ARE JUMPER SELECTABLE ON 6 POINT I/O PC BOARD (N.O. OR N.C.). SEE USER'S MANUAL.

NOTES: TERMINATED AT SITE DURING FINAL INSTALLATION.

DIMENSIONAL TOLERANCES UNLESS OTHERWISE SPECIFIED		USED ON		TELEDYNE MONITOR LABS Everywhere you look
FRACTIONS	DECIMALS	DASH	NEXT ASSEMBLY	
0 TO 4 1/2"	±0.005	1900-0000		TITLE ULTRAFLOW 150 DIRECT INTERFACE WIRING DIAGRAM (115/230 VAC)
4 TO 8 1/2"	±0.010			
8 TO 16 1/2"	±0.020			
16 TO 32 1/2"	±0.040			
ALL DIMENSIONS ARE IN INCHES UNLESS OTHERWISE SPECIFIED DO NOT SCALE THESE DRAWINGS				
AUTHORIZATION				
DRAWN	DCH	9-6-01	MAT'L.	FINISH
CHECKED	ELM	7-18-02		
DESIGNED	DCH	9-6-01	JIS NO.	D 1900-0004
ENGINEERED	ELM	7-18-02		
PRODUCTION	PD	7-19-02	SCALE	F
PROJECTION	AS	7-18-02	2.12	

TRANSUCER INTERFACE ENCLOSURE 1903-0000

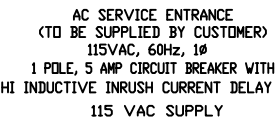
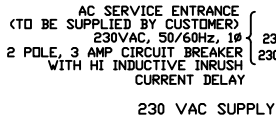
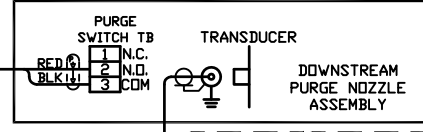
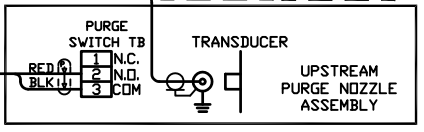
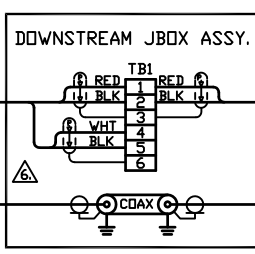
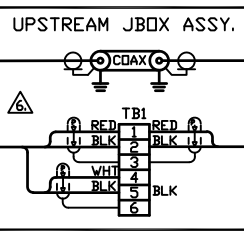
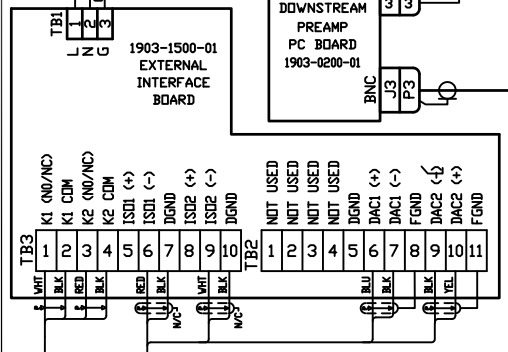
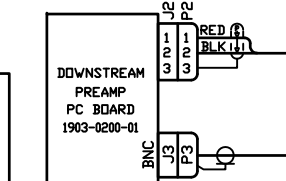
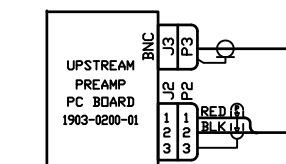
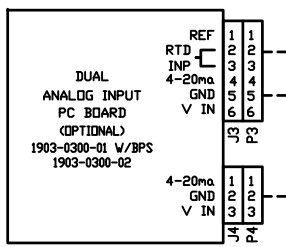

TO CUSTOMER DIRECT INTERFACE EQUIPMENT

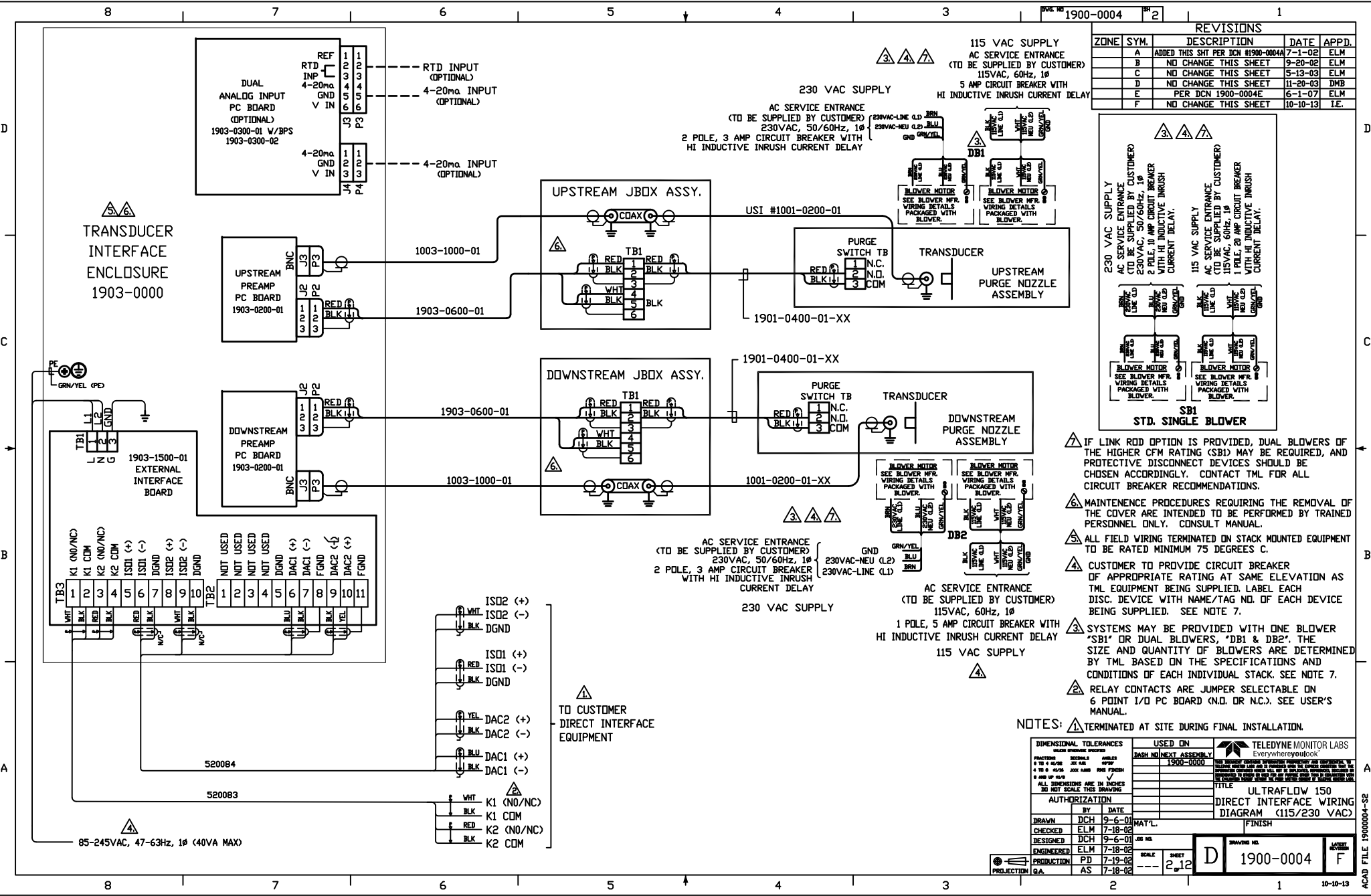
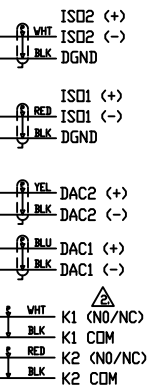

85-245VAC, 47-63Hz, 1Ø (40VA MAX)

REVOLUTIONS		DATE	APPD.
ZONE	SYM.	DESCRIPTION	
A		ADDED THIS SHT PER DCN 1900-0004A	7-1-02 ELM
B		NO CHANGE THIS SHEET	9-20-02 ELM
C		PER DCN 1900-0004C	5-13-03 ELM
D		PER DCN 1900-0004D	11-19-03 DMB
E		PER DCN 1900-0004E	6-1-07 ELM
F		PER DCN 1900-0004F	10-10-13 I.E.

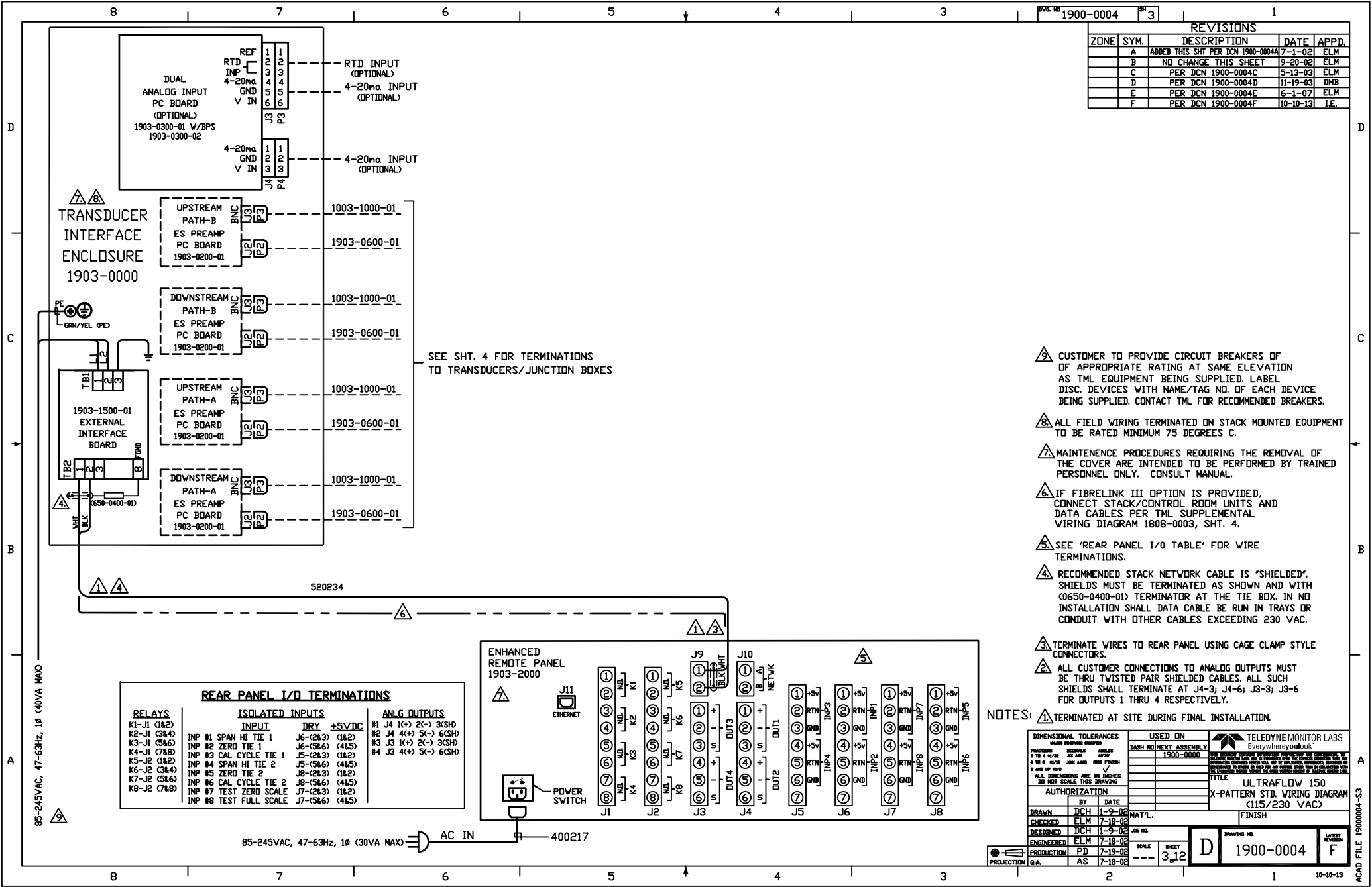

SEE SHT. 4 FOR TERMINATIONS TO TRANSUCERS/JUNCTION BOXES

- ⚠ CUSTOMER TO PROVIDE CIRCUIT BREAKERS OF APPROPRIATE RATING AT SAME ELEVATION AS TML EQUIPMENT BEING SUPPLIED. LABEL DISC. DEVICES WITH NAME/TAG NO. OF EACH DEVICE BEING SUPPLIED. CONTACT TML FOR RECOMMENDED BREAKERS.
- ⚠ ALL FIELD WIRING TERMINATED ON STACK MOUNTED EQUIPMENT TO BE RATED MINIMUM 75 DEGREES C.
- ⚠ MAINTENANCE PROCEDURES REQUIRING THE REMOVAL OF THE COVER ARE INTENDED TO BE PERFORMED BY TRAINED PERSONNEL ONLY. CONSULT MANUAL.
- ⚠ IF FIBRELINK III OPTION IS PROVIDED, CONNECT STACK/CONTROL ROOM UNITS AND DATA CABLES PER TML SUPPLEMENTAL WIRING DIAGRAM 1808-0003, SHT. 4.
- ⚠ SEE 'REAR PANEL I/O TABLE' FOR WIRE TERMINATIONS.
- ⚠ RECOMMENDED STACK NETWORK CABLE IS 'SHIELDED'. SHIELDS MUST BE TERMINATED AS SHOWN AND WITH (0650-0400-01) TERMINATOR AT THE TIE BOX. IN NO INSTALLATION SHALL DATA CABLE BE RUN IN TRAYS OR CONDUIT WITH OTHER CABLES EXCEEDING 230 VAC.
- ⚠ TERMINATE WIRES TO REAR PANEL USING CAGE CLAMP STYLE CONNECTORS.
- ⚠ ALL CUSTOMER CONNECTIONS TO ANALOG OUTPUTS MUST BE THRU TWISTED PAIR SHIELDED CABLES. ALL SUCH SHIELDS SHALL TERMINATE AT J4-3; J4-6; J3-3; J3-6 FOR OUTPUTS 1 THRU 4 RESPECTIVELY.

REAR PANEL I/O TERMINATIONS			
RELAYS	ISOLATED INPUTS	INPUT	ANLG OUTPUTS
K1-J1 (1&2)	INP #1 SPAN HI TIE 1	J6-(2&3) (1&2)	#1 J4 1(+)-2(-) 3(SHD)
K2-J1 (3&4)	INP #2 ZERO TIE 1	J6-(5&6) (4&5)	#2 J4 4(+)-5(-) 6(SHD)
K3-J1 (5&6)	INP #3 CAL CYCLE TIE 1	J5-(2&3) (1&2)	#3 J3 1(+)-2(-) 3(SHD)
K4-J1 (7&8)	INP #4 SPAN HI TIE 2	J5-(5&6) (4&5)	#4 J3 4(+)-5(-) 6(SHD)
K5-J2 (1&2)	INP #5 ZERO TIE 2	J6-(2&3) (1&2)	
K6-J2 (3&4)	INP #6 CAL CYCLE TIE 2	J6-(5&6) (4&5)	
K7-J2 (5&6)	INP #7 TEST ZERO SCALE	J7-(2&3) (1&2)	
K8-J2 (7&8)	INP #8 TEST FULL SCALE	J7-(5&6) (4&5)	

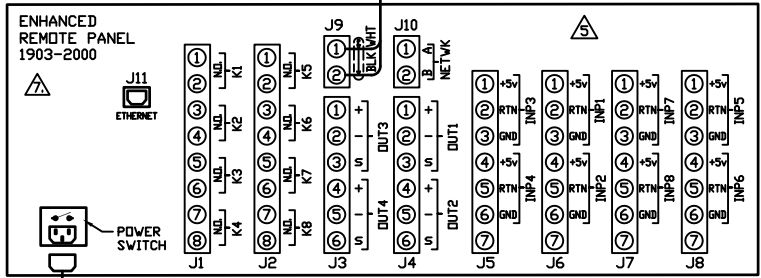

NOTES: ⚠ TERMINATED AT SITE DURING FINAL INSTALLATION.

DIMENSIONAL TOLERANCES UNLESS OTHERWISE SPECIFIED		USED IN		TELEDYNE MONITOR LABS Everywhere you look	
FRACTION	DECIMAL	DASH	NEXT ASSEMBLY	TITLE	
0 TO 4 1/16"	0.005	1900-0000		ULTRAFLUW 150	
4 TO 8 1/16"	0.010			X-PATTERN STD. WIRING DIAGRAM	
8 TO 16 1/16"	0.020			(115/230 VAC)	
16 TO 24 1/16"	0.030			FINISH	
ALL DIMENSIONS ARE IN INCHES DO NOT SCALE THESE DRAWINGS		AUTHORIZATION		DRAWING NO.	
		BY DATE		1900-0004	
		DRAWN DCH 1-9-02		LATEST REVISION	
		CHECKED ELM 7-18-02		F	
		DESIGNED DCH 1-9-02		SCALE	
		ENGINEERED ELM 7-18-02		SHEET	
		PRODUCTION PD 7-19-02		3.12	
		PROJECT G.A. 7-18-02		JOB NO.	

85-245VAC, 47-63Hz, 1ø (40VA MAX)

85-245VAC, 47-63Hz, 1ø (30VA MAX) AC IN 400217

ZONE	SYM.	DESCRIPTION	DATE	APPD.
A		ADDED THIS SHEET PER DCN 1900-0004A	7-1-02	ELM
B		PER DCN 1900-0004B	9-25-02	ELM
C		NO CHANGE THIS SHEET	5-13-03	ELM
D		NO CHANGE THIS SHEET	11-20-03	DMB
E		PER DCN 1900-0004E	6-1-07	ELM
F		NO CHANGE THIS SHEET	10-10-13	I.E.

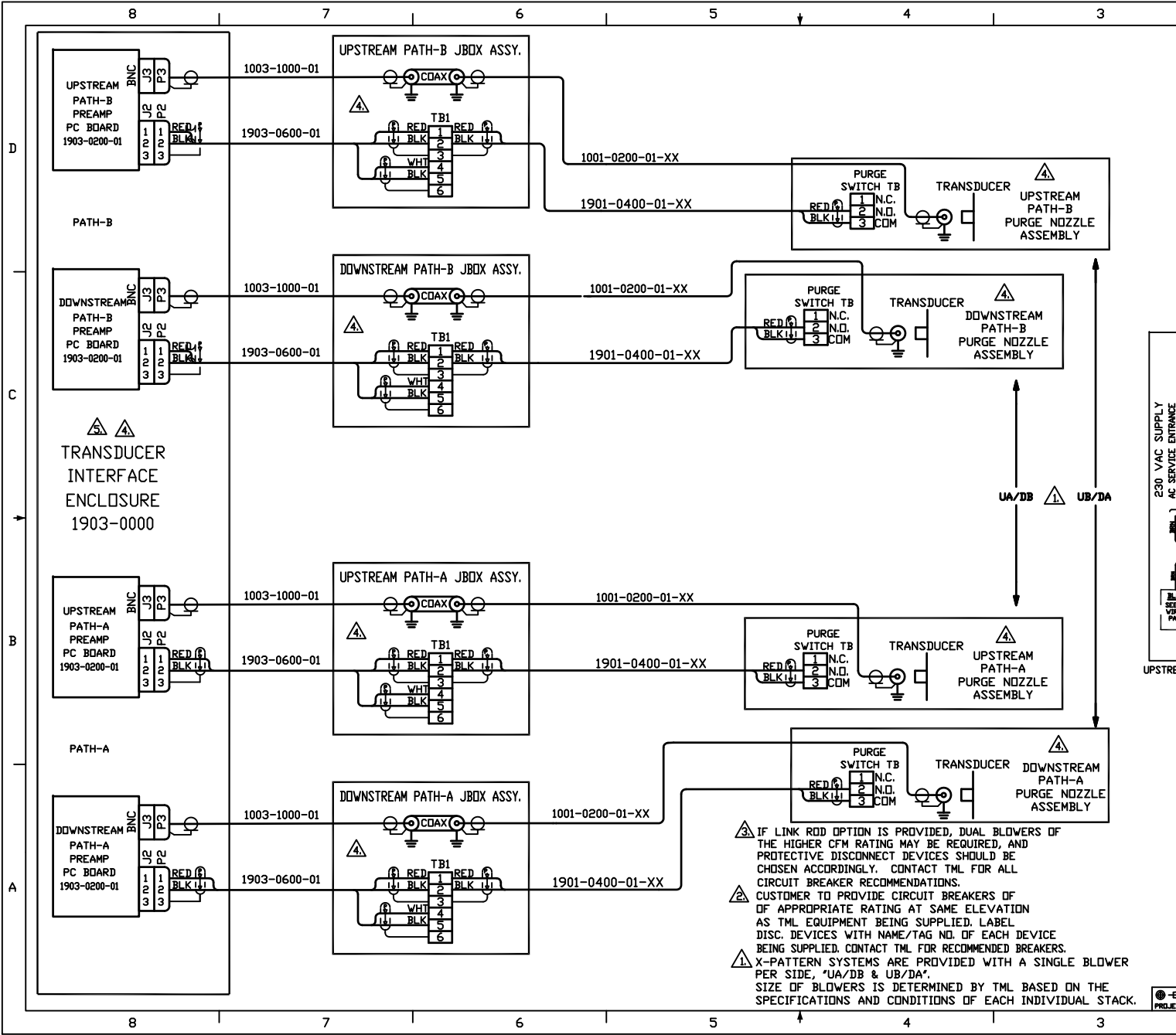

⚠ ALL FIELD WIRING TERMINATED ON STACK MOUNTED EQUIPMENT TO BE RATED MINIMUM 75 DEGREES C.

⚠ MAINTENANCE PROCEDURES REQUIRING THE REMOVAL OF THE COVER ARE INTENDED TO BE PERFORMED BY TRAINED PERSONNEL ONLY. CONSULT MANUAL.

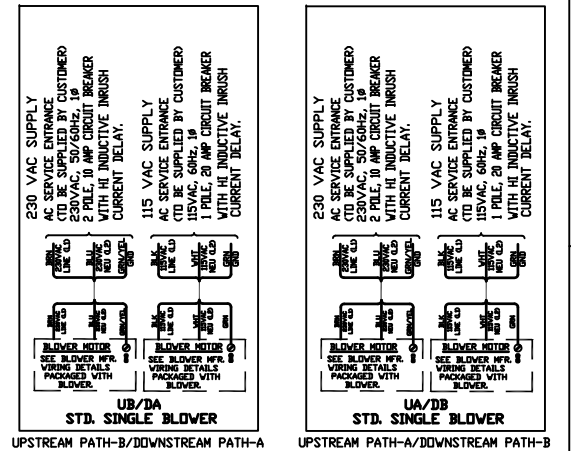

BLOWERS
 ⚠ ⚠ ⚠

NOTE:
 FOR STANDARD (LOWWORKS) NETWORK,
 USE WITH SHEET 3.
 FOR DIRECT INTERFACE SYSTEMS,
 USE WITH SHEET 5.

⚠ IF LINK ROD OPTION IS PROVIDED, DUAL BLOWERS OF THE HIGHER CFM RATING MAY BE REQUIRED, AND PROTECTIVE DISCONNECT DEVICES SHOULD BE CHOSEN ACCORDINGLY. CONTACT TML FOR ALL CIRCUIT BREAKER RECOMMENDATIONS. CUSTOMER TO PROVIDE CIRCUIT BREAKERS OF APPROPRIATE RATING AT SAME ELEVATION AS TML EQUIPMENT BEING SUPPLIED. LABEL DISC. DEVICES WITH NAME/TAG NO. OF EACH DEVICE BEING SUPPLIED. CONTACT TML FOR RECOMMENDED BREAKERS.

⚠ X-PATTERN SYSTEMS ARE PROVIDED WITH A SINGLE BLOWER PER SIDE, 'UA/DB & UB/DA'. SIZE OF BLOWERS IS DETERMINED BY TML BASED ON THE SPECIFICATIONS AND CONDITIONS OF EACH INDIVIDUAL STACK.

DIMENSIONAL TOLERANCES UNLESS OTHERWISE SPECIFIED		USED ON		TELEDYNE MONITOR LABS Everywhere you look	
FRACTION	DECIMAL	DASH	NEXT ASSEMBLY	TELETEST CENTER TORONTO	
3/16 TO 4/8	.005	1900-0000		TITLE	
5/16 TO 1/2	.010			ULTRAFLW 150	
1/2 TO 1	.015			X-PATTERN WIRING DIAGRAM	
1 TO 2	.020			(115/230 VAC)	
2 TO 3	.030			FINISH	
3 TO 4	.040			AUTHORIZATION	
4 TO 5	.050			BY DATE	
5 TO 6	.060			DRAWN DCH 8-30-01	
6 TO 7	.070			CHECKED ELM 7-18-02	
7 TO 8	.080			DESIGNED DCH 1-10-02	
8 TO 9	.090			ENGINEERED ELM 7-18-02	
9 TO 10	.100			PRODUCTION PD 7-19-02	
10 TO 11	.110			PRODUCTION AS 7-18-02	
11 TO 12	.120			SCALE SHEET	
12 TO 13	.130			4 of 12	
13 TO 14	.140			DRAWING NO. 1900-0004	
14 TO 15	.150			LAST REVISION F	

REVISIONS

ZONE	SYM.	DESCRIPTION	DATE	APPD.
A		ADDED THIS SHT PER DCN 1900-0004A	7-1-02	ELM
B		NO CHANGE THIS SHEET	9-20-02	ELM
C		NO CHANGE THIS SHEET	5-13-03	ELM
D		NO CHANGE THIS SHEET	11-20-03	DMB
E		PER DCN 1900-0004E	6-1-07	ELM
F		PER DCN 1900-0004F	10-10-13	I.E.

TRANSUCER INTERFACE ENCLOSURE 1903-0000

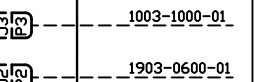
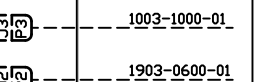
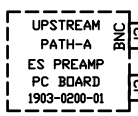
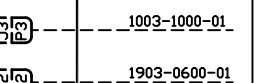
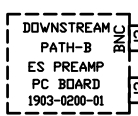
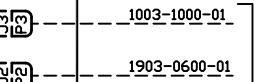
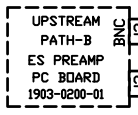
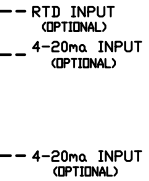
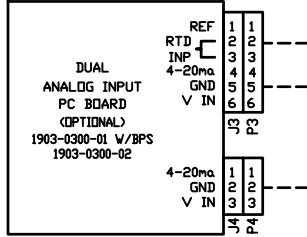

SEE SHT. 4 FOR TERMINATIONS TO TRANSDUCERS/JUNCTION BOXES

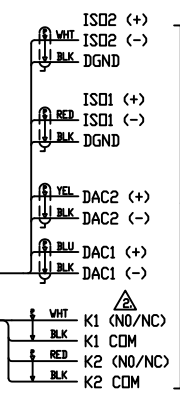
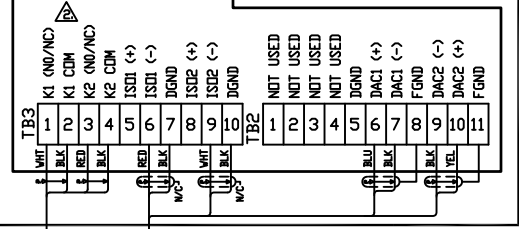

TO CUSTOMER DIRECT INTERFACE EQUIPMENT

85-245VAC, 47-63Hz, 1Ø (40VA MAX)

- ⚠ MAINTENANCE PROCEDURES REQUIRING THE REMOVAL OF THE COVER ARE INTENDED TO BE PERFORMED BY TRAINED PERSONNEL ONLY. CONSULT MANUAL.
- ⚠ CUSTOMER TO PROVIDE CIRCUIT BREAKER OF APPROPRIATE RATING AT SAME ELEVATION AS TML EQUIPMENT BEING SUPPLIED. LABEL EACH DISC. DEVICE WITH NAME/TAG NO. OF EACH DEVICE BEING SUPPLIED. SEE NOTE 7.
- ⚠ ALL FIELD WIRING TERMINATED ON STACK MOUNTED EQUIPMENT TO BE RATED MINIMUM 75 DEGREES C.
- ⚠ RELAY CONTACTS ARE JUMPER SELECTABLE ON 6 POINT 1/Ø PC BOARD (N.O. OR N.C.). SEE USER'S MANUAL.

NOTES: ⚠ TERMINATED AT SITE DURING FINAL INSTALLATION.

DIMENSIONAL TOLERANCES UNLESS OTHERWISE SPECIFIED			USED ON		TELEDYNE MONITOR LABS Everywhere you look
FRACTION	DECIMAL	HOLE	DASH	MINI/NEXT ASSEMBLY	
0 TO 4 1/8"	0.005	0.005		1900-0000	TITLE: ULTRAFLOW 150 X-PATTERN D.I. WIRING DIAGRAM (115/230 VAC) FINISH:
4 TO 8 1/8"	0.010	0.010			
8 TO 8 1/2"	0.015	0.015			
8 1/2 TO 10 1/2"	0.020	0.020			
ALL DIMENSIONS ARE IN INCHES UNLESS OTHERWISE SPECIFIED DO NOT SCALE THESE DRAWINGS					
AUTHORIZATION					
BY		DATE			
DRAWN		DCH 1-9-02		MAT'L.	
CHECKED		ELM 7-18-02			
DESIGNED		DCH 1-10-02		JWG NO.	
ENGINEERED		ELM 7-18-02			
PRODUCTION		PD 7-19-02			
G.A.		AS 7-18-02			



SCALE: 5/12 SHEET: D

1900-0004 F

ZONE	SYM.	DESCRIPTION	DATE	APPD.
A		PER DCN 1900-0004A	7-1-02	ELM
B		PER DCN 1900-0004B	9-26-02	ELM
C		PER DCN 1900-0004C	5-13-03	ELM
D		PER DCN 1900-0004D	11-19-03	DMB
E		PER DCN 1900-0004E	6-1-07	ELM
F		PER DCN 1900-0004F	10-10-13	I.E.

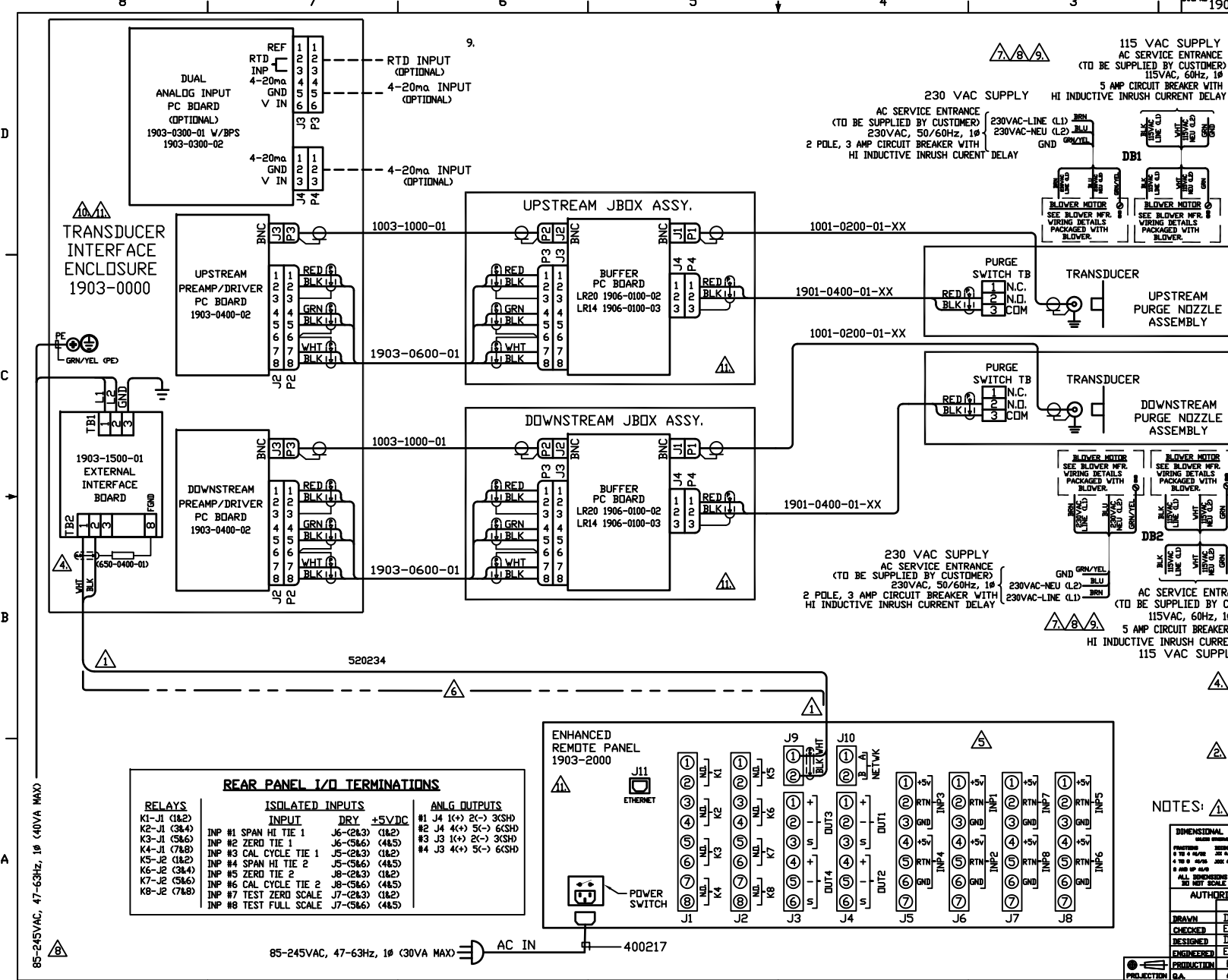

- ⚠ MAINTENANCE PROCEDURES REQUIRING THE REMOVAL OF THE COVER ARE INTENDED TO BE PERFORMED BY TRAINED PERSONNEL ONLY. CONSULT MANUAL.
- ⚠ ALL FIELD WIRING TERMINATED ON STACK MOUNTED EQUIPMENT TO BE RATED MINIMUM 75 DEGREES C.
- ⚠ IF LINK ROD OPTION IS PROVIDED, DUAL BLOWERS WITH THE HIGHER CFM RATING MAY BE REQUIRED, AND PROTECTIVE DISCONNECT DEVICES SHOULD BE CHOSEN ACCORDINGLY. CONSULT MANUAL. CONTACT TML FOR CIRCUIT BREAKER RECOMMENDATIONS.
- ⚠ CUSTOMER TO PROVIDE CIRCUIT BREAKERS OF APPROPRIATE RATING AT SAME ELEVATION AS TML EQUIPMENT BEING SUPPLIED. LABEL BREAKERS WITH NAME/TAG NO. OF EACH DEVICE BEING SUPPLIED. CONTACT TML FOR RECOMMENDED CIRCUIT BREAKERS.
- ⚠ SYSTEMS ARE PROVIDED WITH DUAL BLOWERS, DB1 AND DB2 ONLY. THE SIZE OF THE BLOWERS IS DETERMINED BY TML BASED ON THE SPECIFICATIONS AND CONDITIONS OF EACH INDIVIDUAL STACK. SEE NOTES 8 AND 9.
- ⚠ IF FIBRELINK III OPTION IS PROVIDED, CONNECT STACK/CONTROL ROOM UNITS AND DATA CABLES PER TML SUPPLEMENTAL WIRING DIAGRAM 1808-0003, SHT. 4.
- ⚠ SEE "REAR PANEL I/O TABLE" FOR WIRE TERMINATIONS. TERMINATE WIRES TO REAR PANEL WITH CAGE CLAMP TYPE CONNECTORS PROVIDED.
- ⚠ RECOMMENDED STACK NETWORK CABLE IS "SHIELDED". SHIELDS MUST BE TERMINATED AS SHOWN AND WITH RC NETWORK (0650-0400-01) AT THE TIE BOX. IN NO INSTALLATION SHALL DATA CABLE BE RUN IN TRAYS OR CONDUIT WITH OTHER CABLES EXCEEDING 230 VAC.
- ⚠ ALL CUSTOMER CONNECTIONS TO ANALOG OUTPUTS MUST BE THRU TWISTED PAIR SHIELDED CABLES. ALL SUCH SHIELDS SHALL TERMINATE AT J4-3) J4-6) J3-3) J3-6 FOR OUTPUTS 1 THRU 4 RESPECTIVELY.

NOTES: ⚠ TERMINATED AT SITE DURING FINAL INSTALLATION.

DIMENSIONAL TOLERANCES UNLESS OTHERWISE SPECIFIED			USED ON		TELEDYNE MONITOR LABS Everywhereyoulook	
FINISH	FORM	GROUP	DATE	1900-0000		
0 TO 4 SIZE	SEE CAD	SEE PUGH				
4 TO 8 SIZE	SEE CAD	SEE PUGH				
8 TO 16 SIZE	SEE CAD	SEE PUGH				
16 TO 48 SIZE	SEE CAD	SEE PUGH				
ALL DIMENSIONS ARE IN INCHES UNLESS OTHERWISE SPECIFIED						
AUTHORIZATION			TITLE			
BY DATE			ULTRAFLW 150			
DRAWN DCH 8-30-01			LONG RANGE STD WIRING DIAGRAM			
CHECKED ELM 7-18-02			(115/230 VAC)			
DESIGNED DCH 1-10-02			FINISH			
ENGINEERED ELM 7-18-02			SCALE			
PRODUCTION PD 7-19-02			SHEET			
PRODUCTION AS 7-18-02			D 1900-0004 F			

REVISIONS				
ZONE	SYM.	DESCRIPTION	DATE	APPD.
	A	ADDED THIS SHIT PER DCN 1900-0004A	7-1-02	ELM
	B	PER DCN 1900-0004B	9-26-02	ELM
	C	NO CHANGE THIS SHEET	5-13-03	ELM
	D	NO CHANGE THIS SHEET	11-20-03	DMB
	E	PER DCN 1900-0004E	6-1-07	ELM
	F	PER DCN 1900-0004F	10-10-13	I.E.

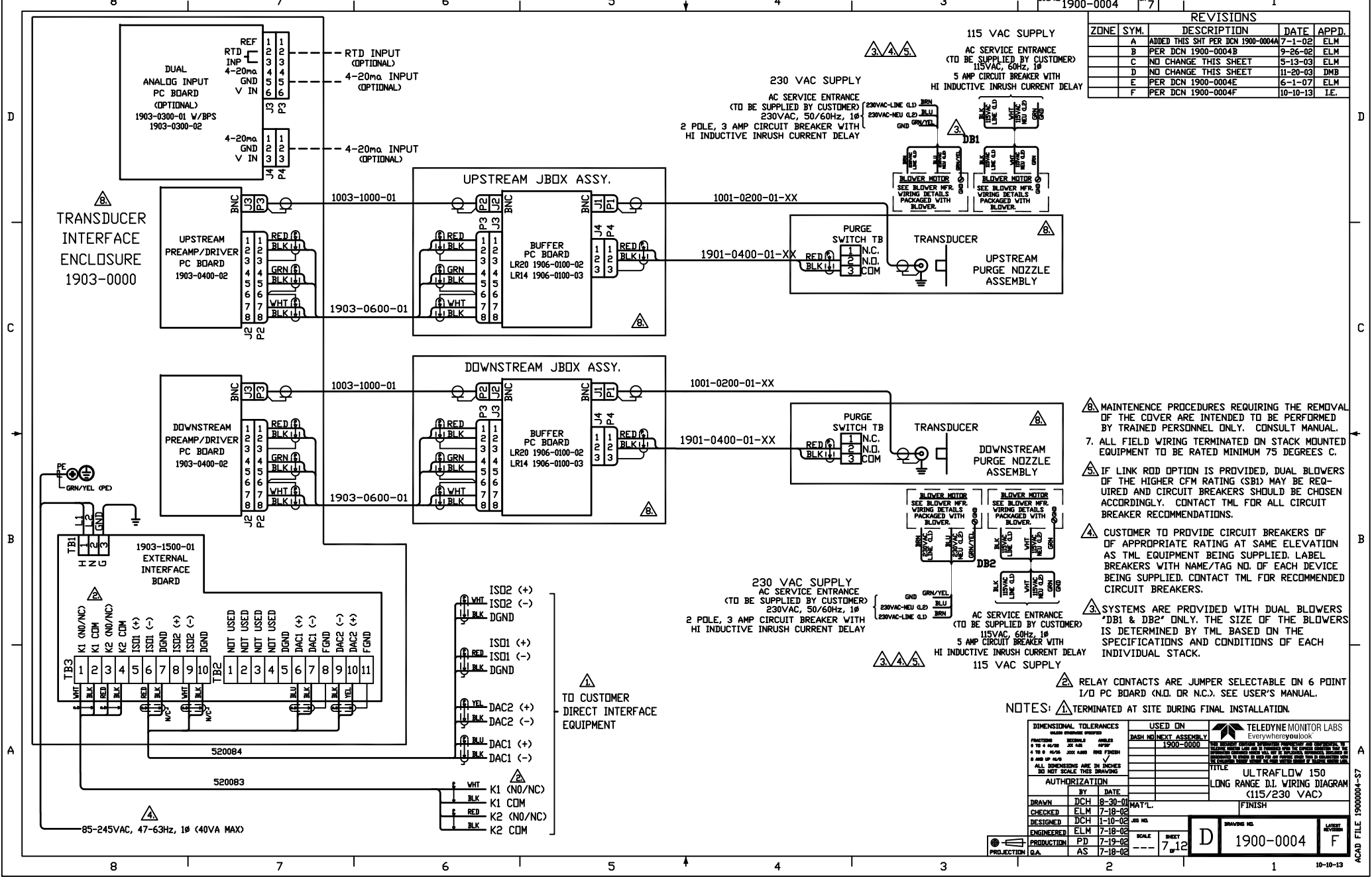

- ⚠ MAINTENANCE PROCEDURES REQUIRING THE REMOVAL OF THE COVER ARE INTENDED TO BE PERFORMED BY TRAINED PERSONNEL ONLY. CONSULT MANUAL.
- 7. ALL FIELD WIRING TERMINATED ON STACK MOUNTED EQUIPMENT TO BE RATED MINIMUM 75 DEGREES C.
- ⚠ IF LINK ROD OPTION IS PROVIDED, DUAL BLOWERS OF THE HIGHER CFM RATING (SB1) MAY BE REQUIRED AND CIRCUIT BREAKERS SHOULD BE CHOSEN ACCORDINGLY. CONTACT TML FOR ALL CIRCUIT BREAKER RECOMMENDATIONS.
- ⚠ CUSTOMER TO PROVIDE CIRCUIT BREAKERS OF OF APPROPRIATE RATING AT SAME ELEVATION AS TML EQUIPMENT BEING SUPPLIED. LABEL BREAKERS WITH NAME/TAG NO. OF EACH DEVICE BEING SUPPLIED. CONTACT TML FOR RECOMMENDED CIRCUIT BREAKERS.
- ⚠ SYSTEMS ARE PROVIDED WITH DUAL BLOWERS 'DB1 & DB2' ONLY. THE SIZE OF THE BLOWERS IS DETERMINED BY TML BASED ON THE SPECIFICATIONS AND CONDITIONS OF EACH INDIVIDUAL STACK.

⚠ RELAY CONTACTS ARE JUMPER SELECTABLE ON 6 POINT I/O PC BOARD (N.O. OR N.C.). SEE USER'S MANUAL.

NOTES: ⚠ TERMINATED AT SITE DURING FINAL INSTALLATION.

DIMENSIONAL TOLERANCES UNLESS OTHERWISE SPECIFIED		USED ON		TELEDYNE MONITOR LABS Everywhere you look
FRACTION	DECIMAL	DASH	NEXT ASSEMBLY	
0 TO 4 1/8"	±0.010	1900-0000		<small>THESE DIMENSIONAL TOLERANCES APPLY TO ALL DIMENSIONS UNLESS OTHERWISE SPECIFIED. ALL DIMENSIONS ARE IN INCHES UNLESS OTHERWISE SPECIFIED. ALL DIMENSIONS ARE TO BE TAKEN FROM THE UNFINISHED SURFACE UNLESS OTHERWISE SPECIFIED. ALL DIMENSIONS ARE TO BE TAKEN FROM THE UNFINISHED SURFACE UNLESS OTHERWISE SPECIFIED.</small>
4 TO 8 1/8"	±0.015			
8 TO 16 1/8"	±0.020			
16 TO 32 1/8"	±0.030			
ALL DIMENSIONS ARE IN INCHES UNLESS OTHERWISE SPECIFIED. DO NOT SCALE THESE DRAWINGS.				
AUTHORIZATION BY DATE DRAWN DCH 8-30-01 CHECKED ELM 7-18-02 DESIGNED DCH 1-10-02 ENGINEERED ELM 7-18-02 PRODUCTION PD 7-19-02 PRODUCTION G.A. 7-18-02				
TITLE ULTRAFLOW 150 LONG RANGE D.I. WIRING DIAGRAM (115/230 VAC) FINISH				
DRAWING NO. 1900-0004				SHEET 7 OF 12
LAST REVISION F				

REVOLUTIONS		DATE	APPD.
ZONE	SYM.	DESCRIPTION	
A		ADDED THIS SHT PER DCN 1900-0004A	7-1-02 ELM
B		NO CHANGE THIS SHEET	9-20-02 ELM
C		PER DCN 1900-0004C	5-13-03 ELM
D		PER DCN 1900-0004D	11-19-03 DMB
E		PER DCN 1900-0004E	6-1-07 ELM
F		PER DCN 1900-0004F	10-10-13 I.E.

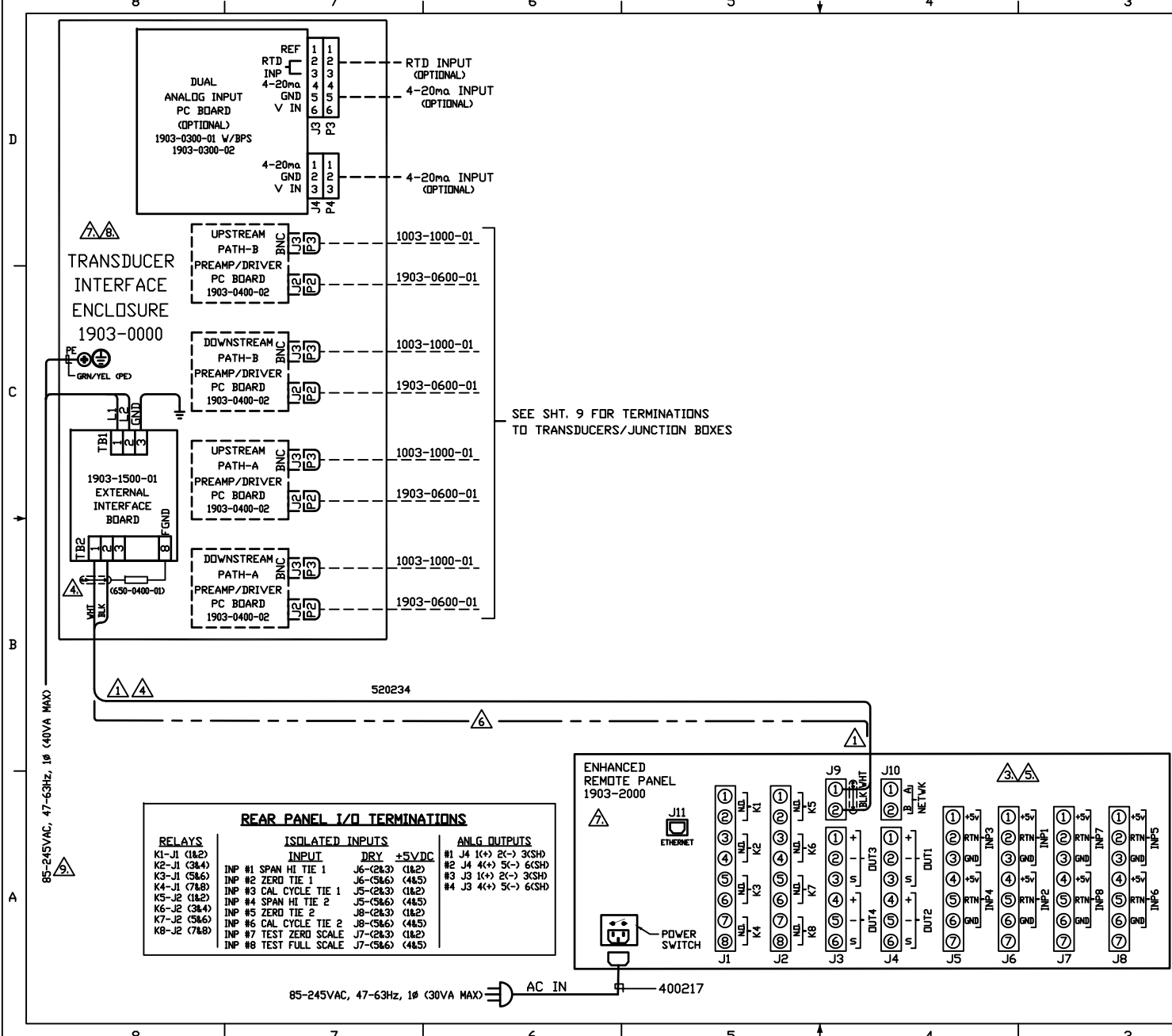

- ⚠ CUSTOMER TO PROVIDE CIRCUIT BREAKERS OF APPROPRIATE RATING AT SAME ELEVATION AS TML EQUIPMENT BEING SUPPLIED. LABEL DISC. DEVICES WITH NAME/TAG NO. OF EACH DEVICE BEING SUPPLIED. CONTACT TML FOR RECOMMENDED BREAKERS.
- ⚠ ALL FIELD WIRING TERMINATED ON STACK MOUNTED EQUIPMENT TO BE RATED MINIMUM 75 DEGREES C.
- ⚠ MAINTENANCE PROCEDURES REQUIRING THE REMOVAL OF THE COVER ARE INTENDED TO BE PERFORMED BY TRAINED PERSONNEL ONLY. CONSULT MANUAL.
- ⚠ IF FIBRELINK III OPTION IS PROVIDED, CONNECT STACK/CONTROL ROOM UNITS AND DATA CABLES PER TML SUPPLEMENTAL WIRING DIAGRAM 1808-0003, SHT. 4.
- ⚠ SEE 'REAR PANEL I/O TABLE' FOR WIRE TERMINATIONS.
- ⚠ RECOMMENDED STACK NETWORK CABLE IS 'SHIELDED'. SHIELDS MUST BE TERMINATED AS SHOWN AND WITH 0650-0400-01 TERMINATOR AT THE TIE BOX. IN NO INSTALLATION SHALL DATA CABLE BE RUN IN TRAYS OR CONDUIT WITH OTHER CABLES EXCEEDING 230 VAC.
- ⚠ TERMINATE WIRES TO REAR PANEL USING CAGE CLAMP STYLE CONNECTORS.
- ⚠ ALL CUSTOMER CONNECTIONS TO ANALOG OUTPUTS MUST BE THRU TWISTED PAIR SHIELDED CABLES. ALL SUCH SHIELDS SHALL TERMINATE AT J4-3; J4-6; J3-3; J3-6 FOR OUTPUTS 1 THRU 4 RESPECTIVELY.

NOTES: ⚠ TERMINATED AT SITE DURING FINAL INSTALLATION.

DIMENSIONAL TOLERANCES UNLESS OTHERWISE SPECIFIED		USED ON		TELEDYNE MONITOR LABS Everywhere you look
FRACTION	DECIMAL	DASH	NEXT ASSEMBLY	
0 TO 4 1/8"	0.005	1900-0000		TITLE: ULTRAFLW 150 L.R. X-PATT. STD. WIRING DIAGRAM (115/230 VAC)
4 TO 8 1/8"	0.010			
8 TO 8 1/2"	0.015			
8 TO 16"	0.030			
ALL DIMENSIONS ARE IN INCHES DO NOT SCALE THIS DRAWING				
AUTHORIZATION				
BY DATE		FINISH		
DRAWN DCH 1-9-02		MATERIAL		
CHECKED ELM 7-18-02		JOB NO.		
DESIGNED DCH 1-10-02		SCALE		
ENGINEERED ELM 7-18-02		SHEET		
PRODUCTION PD 7-19-02		8.12		
PROJECT G.A. 7-18-02		D 1900-0004 F		

ZONE	SYM.	DESCRIPTION	DATE	APPD.
	0	NO CHANGE THIS SHEET	9-20-02	ELM
	1	NO CHANGE THIS SHEET	5-13-03	ELM
	2	NO CHANGE THIS SHEET	11-20-03	DMB
	3	PER DCN 1900-0004E	6-1-07	ELM
	4	NO CHANGE THIS SHEET	10-10-13	I.E.

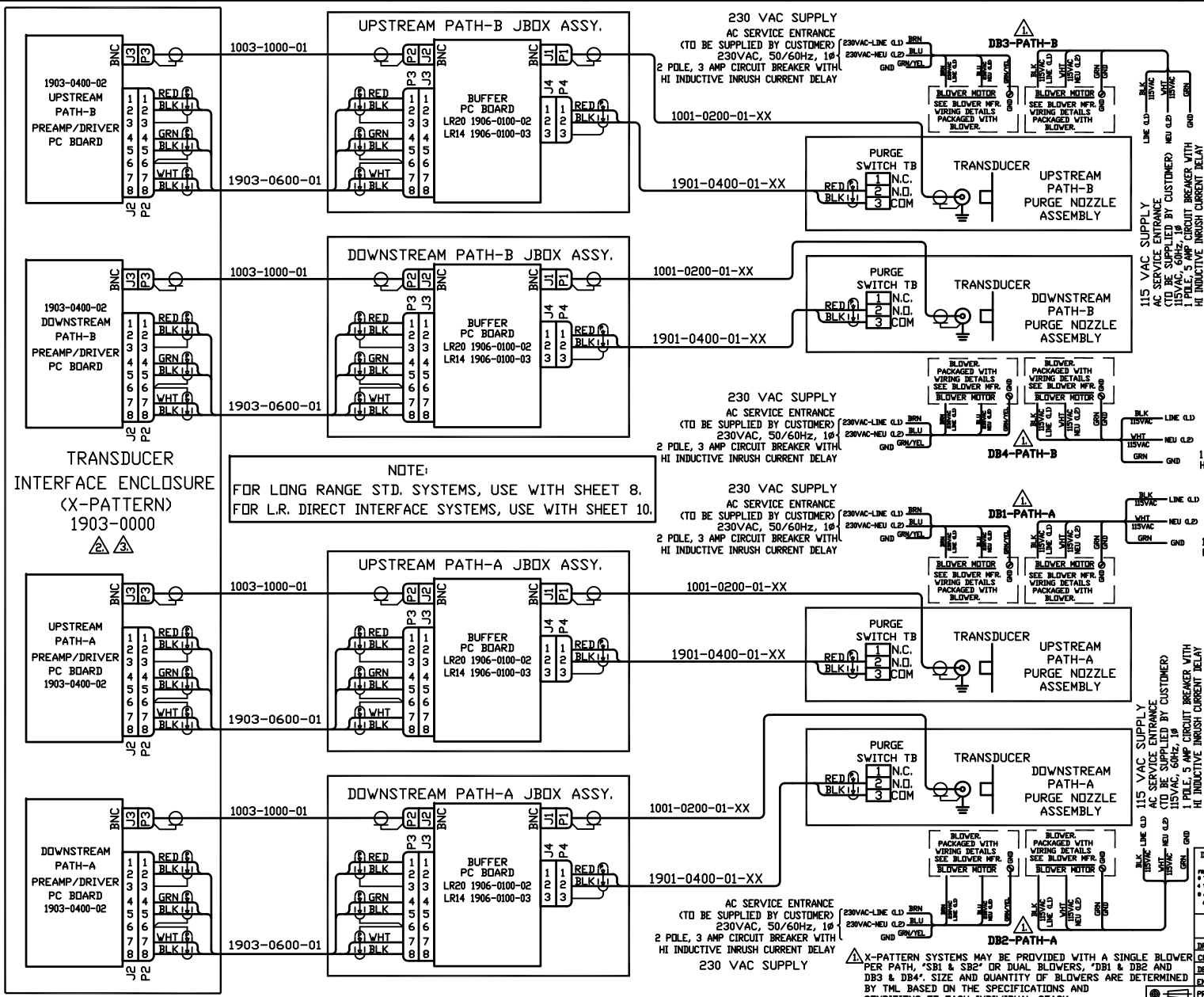

NOTE:
 FOR LONG RANGE STD. SYSTEMS, USE WITH SHEET 8.
 FOR L.R. DIRECT INTERFACE SYSTEMS, USE WITH SHEET 10.

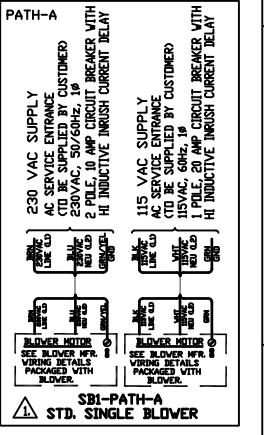
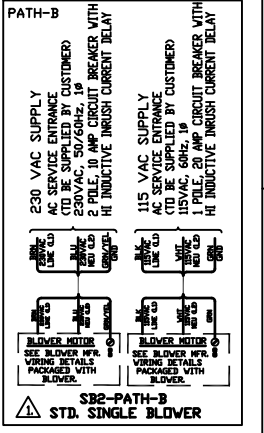

△ CUSTOMER TO PROVIDE CIRCUIT BREAKERS OF APPROPRIATE RATING AT SAME ELEVATION AS THE EQUIPMENT BEING SUPPLIED. LABEL DISC. DEVICES WITH NAME/TAG NO. OF EACH DEVICE BEING SUPPLIED. CONTACT TM FOR RECOMMENDED BREAKERS.
 △ ALL FIELD WIRING TERMINATED ON STACK MOUNTED EQUIPMENT TO BE RATED MINIMUM 75 DEGREES C.
 △ MAINTENANCE PROCEDURES REGARDING THE REMOVAL OF THE COVER ARE INTENDED TO BE PERFORMED BY TRAINED PERSONNEL ONLY. CONSULT MANUAL.

DIMENSIONAL TOLERANCES

FRACTIONS	DECIMALS	MILLIS
± 1/16"	± 0.005"	± 0.025"
± 1/32"	± 0.0025"	± 0.0125"
± 1/64"	± 0.00125"	± 0.00625"

ALL DIMENSIONS ARE IN INCHES UNLESS OTHERWISE SPECIFIED.
 DIMENSIONS DO NOT SCALE THESE DRAWINGS.

USED ON

DRAWN	DCH	8-30-01	MAT'L.
CHECKED	ELM	7-18-02	
DESIGNED	DCH	1-10-02	
ENGINEERED	ELM	7-18-02	
PRODUCTION	PD	7-19-02	
PRODUCTION	AS	7-18-02	

TELEDYNE MONITOR LABS
 Everywhere you look

ULTRAFLOW 150
 L.R. X-PATTERN WIRING DIAGRAM
 (115/230 VAC)

FINISH

SCALE	SHEET	DATE
	9 of 12	9-12

D 1900-0004 **F**

△ X-PATTERN SYSTEMS MAY BE PROVIDED WITH A SINGLE BLOWER PER PATH, "SB1 & SB2" OR DUAL BLOWERS, "DB1 & DB2 AND DB3 & DB4". SIZE AND QUANTITY OF BLOWERS ARE DETERMINED BY TML BASED ON THE SPECIFICATIONS AND CONDITIONS OF EACH INDIVIDUAL STACK.

DRAWING NO. 1900-0004		REV. 10		REV. 1	
REVISIONS					
ZONE	SYM.	DESCRIPTION	DATE	APPD.	
	A	ADDED THIS SHT PER DCN 1900-0004A	7-1-02	ELM	
	B	NO CHANGE THIS SHEET	9-20-02	ELM	
	C	NO CHANGE THIS SHEET	5-13-03	ELM	
	D	NO CHANGE THIS SHEET	11-20-03	DMB	
	E	PER DCN 1900-0004E	6-1-07	ELM	
	F	PER DCN 1900-0004F	10-10-13	I.E.	

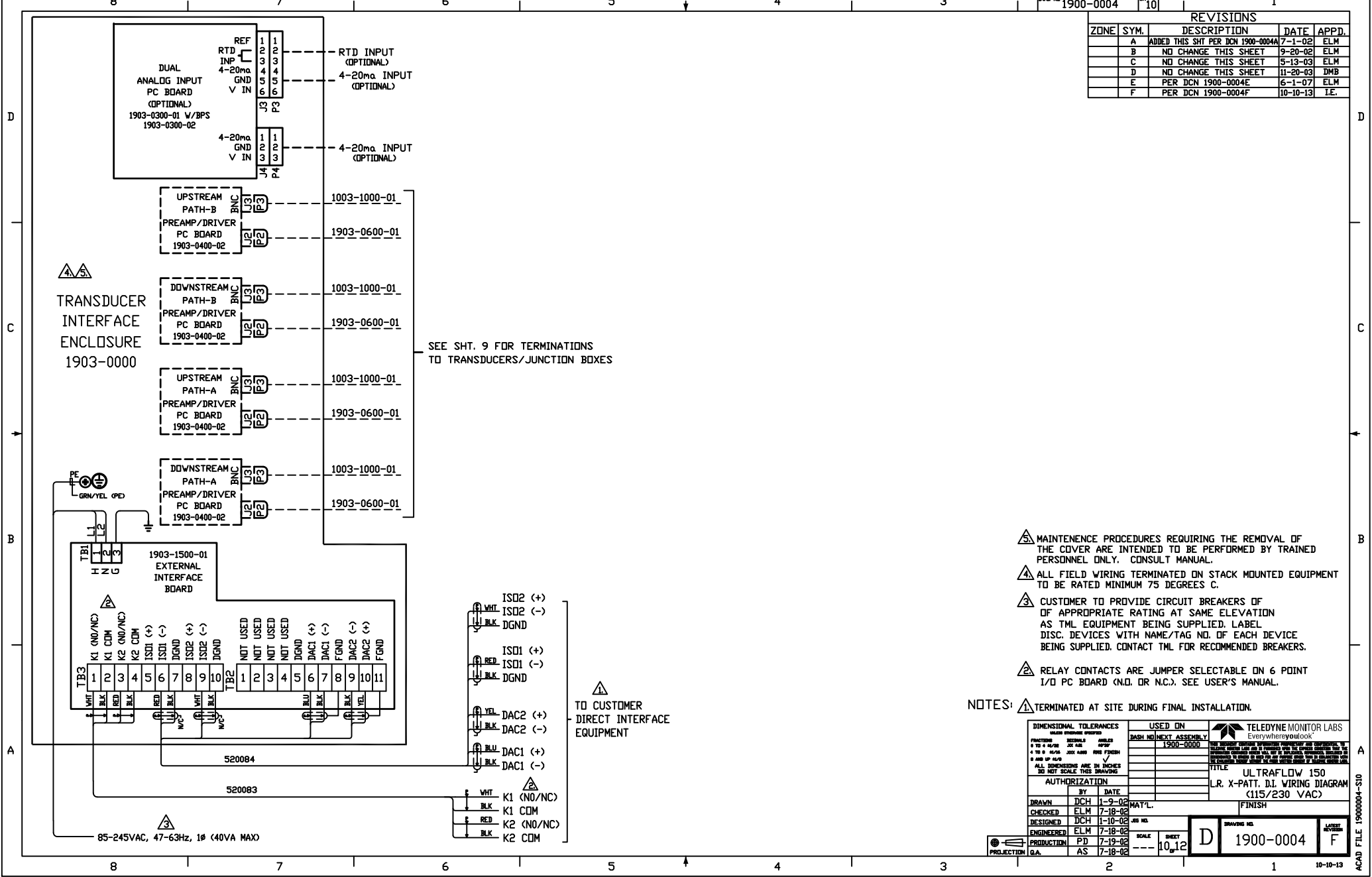

- ⚠ MAINTENANCE PROCEDURES REQUIRING THE REMOVAL OF THE COVER ARE INTENDED TO BE PERFORMED BY TRAINED PERSONNEL ONLY. CONSULT MANUAL.
- ⚠ ALL FIELD WIRING TERMINATED ON STACK MOUNTED EQUIPMENT TO BE RATED MINIMUM 75 DEGREES C.
- ⚠ CUSTOMER TO PROVIDE CIRCUIT BREAKERS OF APPROPRIATE RATING AT SAME ELEVATION AS TML EQUIPMENT BEING SUPPLIED. LABEL DISC. DEVICES WITH NAME/TAG NO. OF EACH DEVICE BEING SUPPLIED. CONTACT TML FOR RECOMMENDED BREAKERS.
- ⚠ RELAY CONTACTS ARE JUMPER SELECTABLE ON 6 POINT I/O PC BOARD (N.O. OR N.C.). SEE USER'S MANUAL.

NOTES: ⚠ TERMINATED AT SITE DURING FINAL INSTALLATION.

DIMENSIONAL TOLERANCES UNLESS OTHERWISE SPECIFIED		USED ON		TELEDYNE MONITOR LABS Everywhere you look!	
FRACTION	DECIMAL	DASH	NEXT ASSEMBLY	TITLE	
0 TO 4 1/8"	±0.005	1900-0000		ULTRAFLOW 150	
4 TO 8 1/8"	±0.008			L.R. X-PATT. DI. WIRING DIAGRAM	
8 TO 16"	±0.010			(115/230 VAC)	
16 TO 30"	±0.015			FINISH	
ALL DIMENSIONS ARE IN INCHES DO NOT SCALE THESE DRAWINGS				DRAWING NO. 1900-0004	
AUTHORIZATION		BY DATE		LATEST REVISION	
		DCH 1-9-02		F	
		ELM 7-18-02			
		PD 7-19-02			
		AS 7-18-02			
SCALE		SHEET		JOB NO.	
10.12		D		1900-0004	
PROJECTION		G.A.		10-10-13	

REVISIONS

ZONE	SYM.	DESCRIPTION	DATE	APPD.
A		PER DCN #1900-0004A	7-11-01	ELM
B		PER DCN #1900-0004B	9-26-02	ELM
C		PER DCN #1900-0004C	5-13-03	ELM
D		PER DCN 1900-0004D	11-19-03	DMB
E		PER DCN 1900-0004E	6-1-07	ELM
F		PER DCN 1900-0004F	10-10-13	I.E.

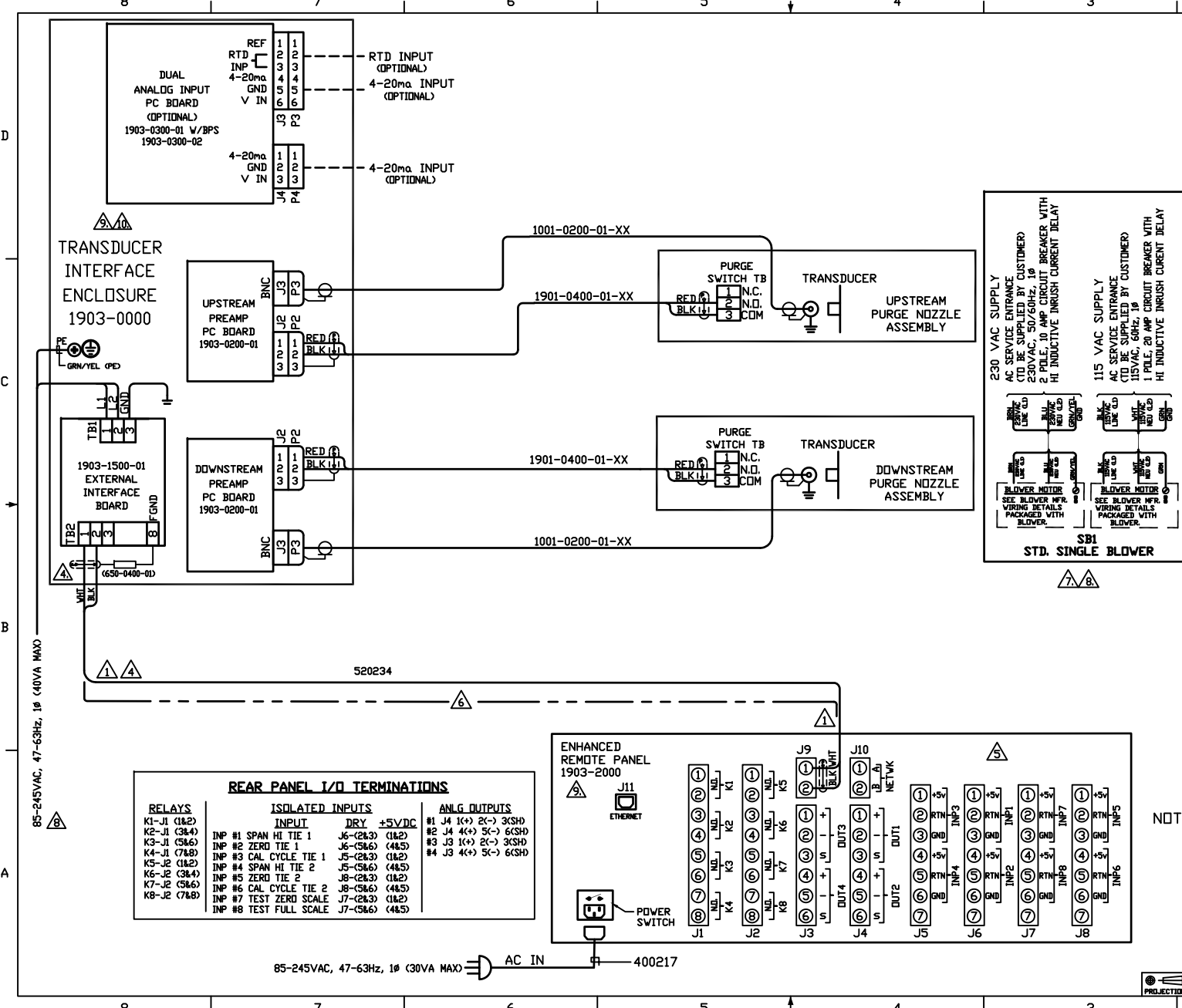

- ⚠ IF LINK ROD OPTION IS PROVIDED, DUAL BLOWERS OF THE HIGHER CFM RATING (SBI) MAY BE REQUIRED, AND PROTECTIVE DISCONNECT DEVICES SHOULD BE CHOSEN ACCORDINGLY. CONTACT TML FOR ALL CIRCUIT BREAKER RECOMMENDATIONS.
- ⚠ ALL FIELD WIRING TERMINATED ON STACK MOUNTED EQUIPMENT TO BE RATED MINIMUM 75 DEGREES C.
- ⚠ MAINTENANCE PROCEDURES REQUIRING THE REMOVAL OF THE COVER ARE INTENDED TO BE PERFORMED BY TRAINED PERSONNEL ONLY. CONSULT MANUAL.
- ⚠ CUSTOMER TO PROVIDE CIRCUIT BREAKERS OF APPROPRIATE RATING AT SAME ELEVATION AS TML EQUIPMENT BEING SUPPLIED. LABEL DISC. DEVICES WITH NAME/TAG NO. OF EACH DEVICE BEING SUPPLIED. CONTACT TML FOR RECOMMENDED BREAKERS.
- ⚠ SYSTEMS ARE PROVIDED WITH ONE BLOWER 'SBI'. OTHER BLOWER SIZES MAY BE RECOMMENDED BY TML BASED ON THE SPECIFICATIONS AND CONDITIONS OF EACH INDIVIDUAL STACK. CONSULT FACTORY.
- ⚠ IF FIBRELINK III OPTION IS PROVIDED, CONNECT STACK/CONTROL ROOM UNITS AND DATA CABLES PER TML SUPPLEMENTAL WIRING DIAGRAM 1808-0003, SHT. 4, AND 1808-0007.
- ⚠ SEE 'REAR PANEL I/O TABLE' FOR WIRE TERMINATIONS.
- ⚠ RECOMMENDED STACK NETWORK CABLE IS 'SHIELDED'. SHIELDS MUST BE TERMINATED AS SHOWN AND WITH TERMINATOR (0650-0400-01) AT THE TIE BOX. IN NO INSTALLATION SHALL DATA CABLE BE RUN IN TRAYS OR CONDUIT WITH OTHER CABLES EXCEEDING 230 VAC.
- 3.
- ⚠ ALL CUSTOMER CONNECTIONS TO ANALOG OUTPUTS MUST BE THRU TWISTED PAIR SHIELDED CABLES. ALL SUCH SHIELDS SHALL TERMINATE AT J4-3) J4-6) J3-3) J3-6 FOR OUTPUTS 1 THRU 4 RESPECTIVELY.

NOTES: ⚠ TERMINATED AT SITE DURING FINAL INSTALLATION.

DIMENSIONAL TOLERANCES UNLESS OTHERWISE SPECIFIED			USED ON		TELEDYNE MONITOR LABS Everywhere you look
FRACTION	DECIMAL	ANGLES	DASH	NEXT ASSEMBLY	
0 TO 4	0.125	±0.005		1900-0000	TITLE ULTRAFLOW 150 ESSO STD. WIRING DIAGRAM (NO JBOXES) - 115/230V FINISH
4 TO 8	0.250	±0.010			
8 TO 16	0.500	±0.020			
16 TO 32	1.000	±0.040			
ALL DIMENSIONS ARE IN INCHES UNLESS OTHERWISE SPECIFIED DO NOT SCALE THIS DRAWING					
AUTHORIZATION BY DATE DCH 3-22-02 CHECKED ELM 5-10-02 DESIGNED DCH 3-22-02 ENGINEERED ELM 5-10-02 PRODUCTION PD 5-10-02 PQA AS 5-10-02					
DIMENSIONAL TOLERANCES UNLESS OTHERWISE SPECIFIED FRACTION DECIMAL ANGLES 0 TO 4 0.125 ±0.005 4 TO 8 0.250 ±0.010 8 TO 16 0.500 ±0.020 16 TO 32 1.000 ±0.040 ALL DIMENSIONS ARE IN INCHES UNLESS OTHERWISE SPECIFIED DO NOT SCALE THIS DRAWING			SCALE SHEET 11.12		DRAWING NO. 1900-0004 REVISED F

DRAWING NO.		1900-0004	REV. NO.		12
REVISIONS					
ZONE	SYM.	DESCRIPTION	DATE	APPD.	
A		ADDED THIS SHEET PER DCN 1900-0004A	7-01-02	ELM	
B		PER DCN 1900-0004B	9-26-02	ELM	
C		PER DCN 1900-0004C	5-13-03	ELM	
D		NO CHANGE THIS SHEET	11-20-03	DMB	
E		PER DCN 1900-0004E	6-1-07	ELM	
F		PER DCN 1900-0004F	10-10-13	I.E.	

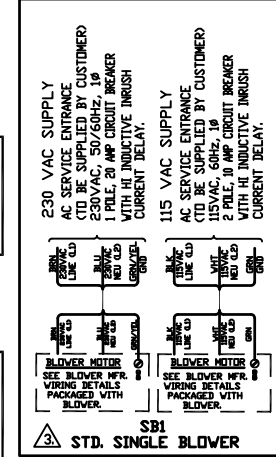
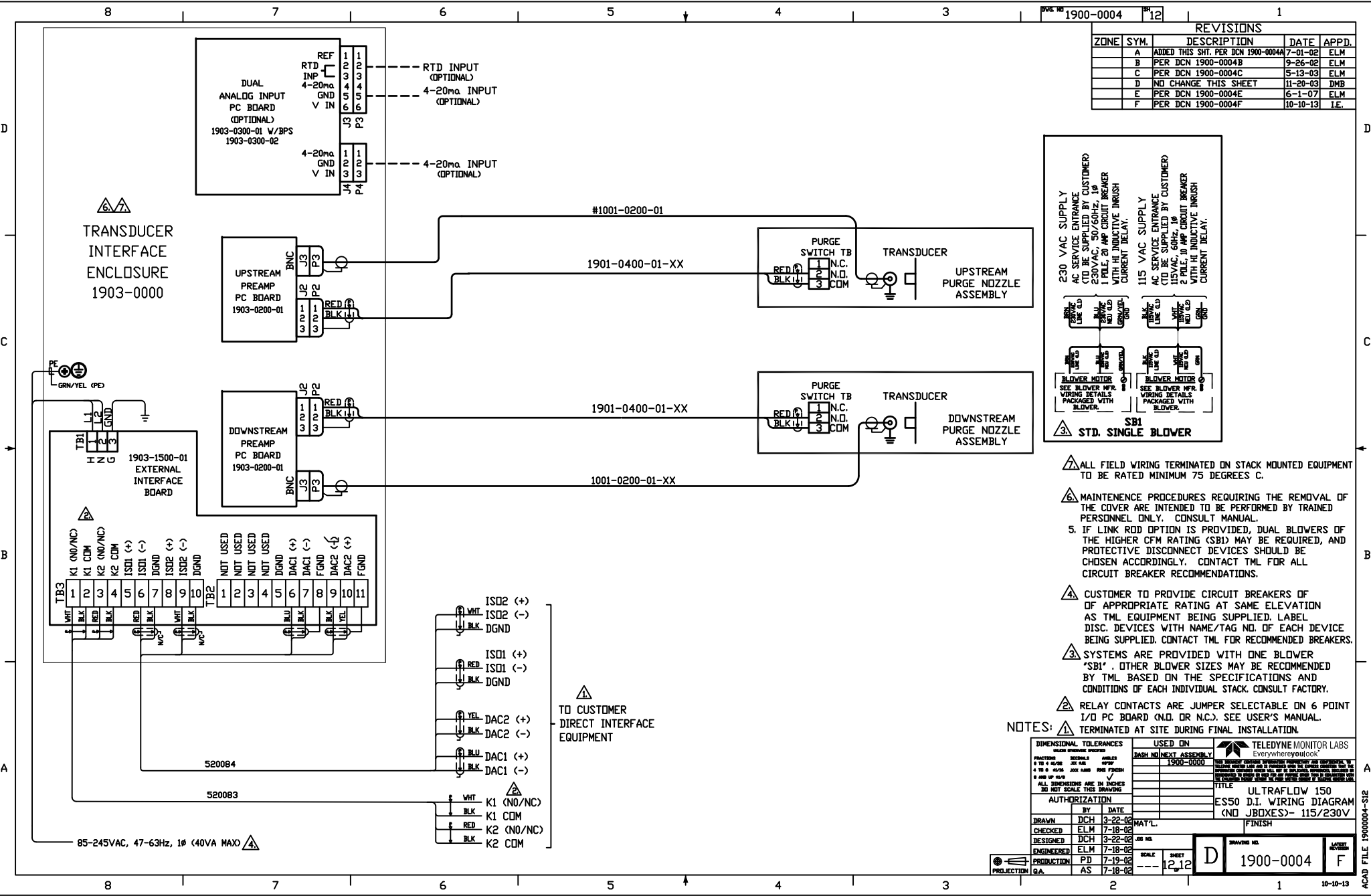

- ⚠ ALL FIELD WIRING TERMINATED ON STACK MOUNTED EQUIPMENT TO BE RATED MINIMUM 75 DEGREES C.
 - ⚠ MAINTENANCE PROCEDURES REQUIRING THE REMOVAL OF THE COVER ARE INTENDED TO BE PERFORMED BY TRAINED PERSONNEL ONLY. CONSULT MANUAL.
 - 5. IF LINK ROD OPTION IS PROVIDED, DUAL BLOWERS OF THE HIGHER CFM RATING (SB1) MAY BE REQUIRED, AND PROTECTIVE DISCONNECT DEVICES SHOULD BE CHOSEN ACCORDINGLY. CONTACT TML FOR ALL CIRCUIT BREAKER RECOMMENDATIONS.
 - ⚠ CUSTOMER TO PROVIDE CIRCUIT BREAKERS OF APPROPRIATE RATING AT SAME ELEVATION AS TML EQUIPMENT BEING SUPPLIED. LABEL DISC. DEVICES WITH NAME/TAG NO. OF EACH DEVICE BEING SUPPLIED. CONTACT TML FOR RECOMMENDED BREAKERS.
 - ⚠ SYSTEMS ARE PROVIDED WITH ONE BLOWER 'SB1'. OTHER BLOWER SIZES MAY BE RECOMMENDED BY TML BASED ON THE SPECIFICATIONS AND CONDITIONS OF EACH INDIVIDUAL STACK. CONSULT FACTORY.
 - ⚠ RELAY CONTACTS ARE JUMPER SELECTABLE ON 6 POINT I/O PC BOARD (N.O. OR N.C.). SEE USER'S MANUAL.
- NOTES:** ⚠ TERMINATED AT SITE DURING FINAL INSTALLATION.

DIMENSIONAL TOLERANCES <small>UNLESS OTHERWISE SPECIFIED</small>		USED ON DASH NEXT ASSEMBLY 1900-0000		TELEDYNE MONITOR LABS <i>Everywhere you look</i>	
FRACTION	DECIMAL	ANGLES	FINISH	NEED ASSISTANT CENTER TO BE CONSIDERED AND SPECIFICALLY Labeled. SPECIAL LABEL AND TO PROVIDE FOR THE COMPANY OFFICE USE. ALL DIMENSIONS ARE IN INCHES UNLESS OTHERWISE SPECIFIED. DIMENSIONS IN PARENTHESIS ARE HIDDEN DIMENSIONS AND SHALL BE SHOWN AS SUCH. DIMENSIONS IN BRACKETED ARE HIDDEN DIMENSIONS AND SHALL BE SHOWN AS SUCH. DIMENSIONS IN DASHED BOXES ARE HIDDEN DIMENSIONS AND SHALL BE SHOWN AS SUCH. DIMENSIONS IN SOLID BOXES ARE HIDDEN DIMENSIONS AND SHALL BE SHOWN AS SUCH.	
0 TO $1/64$	0.000	30	AS FRESH	TITLE ULTRAFLOW 150	
$1/64$ TO $1/32$	0.005	45	AS FRESH	ESSO D.I. WIRING DIAGRAM	
$1/32$ TO $3/16$	0.015	60	AS FRESH	(AND JBOXES)- 115/230V	
$3/16$ TO $1/2$	0.030	75	AS FRESH	FINISH	
> $1/2$	0.060	90	AS FRESH	AUTHORIZATION	
ALL DIMENSIONS ARE IN INCHES UNLESS OTHERWISE SPECIFIED. DIMENSIONS IN PARENTHESIS ARE HIDDEN DIMENSIONS AND SHALL BE SHOWN AS SUCH. DIMENSIONS IN DASHED BOXES ARE HIDDEN DIMENSIONS AND SHALL BE SHOWN AS SUCH. DIMENSIONS IN SOLID BOXES ARE HIDDEN DIMENSIONS AND SHALL BE SHOWN AS SUCH.			BY DATE		
DO NOT SCALE THIS DRAWING			DRAWN DCH 3-22-02		
			CHECKED ELM 7-18-02		
			DESIGNED DCH 3-22-02		
			ENGINEERED ELM 7-18-02		
			PRODUCTION PD 7-19-02		
			PROJECTION G.A. 7-18-02		
SCALE		SHEET		DRAWING NO.	
---		12.12		D 1900-0004	
				LAST REVISED	
				F	

REVISIONS				
ZONE	SYM.	DESCRIPTION	DATE	APPD.
	A	PER DCN #1900-0006A	6-21-02	DMB
	B	PER DCN #1900-0006B	9-17-02	ELM

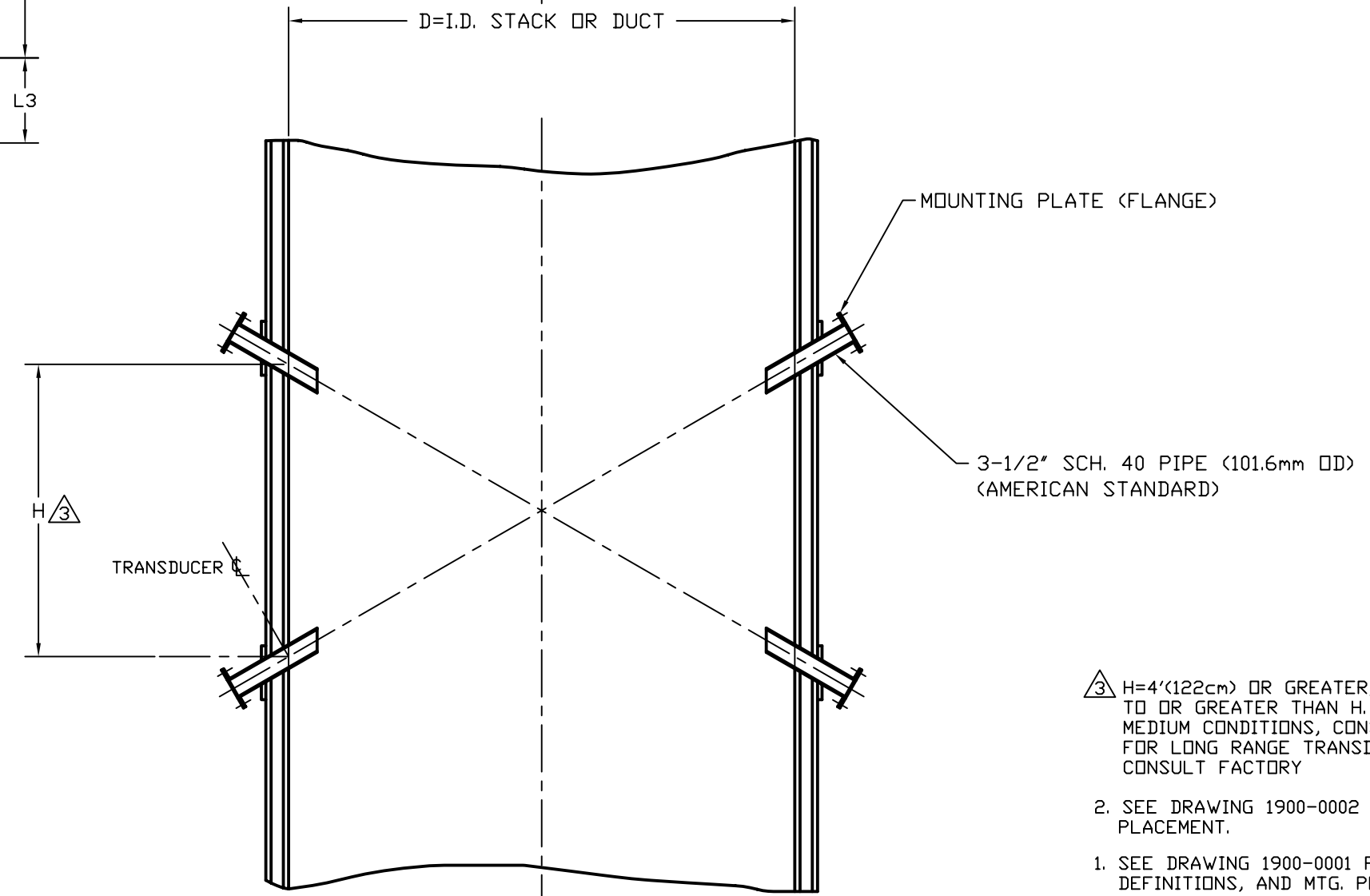
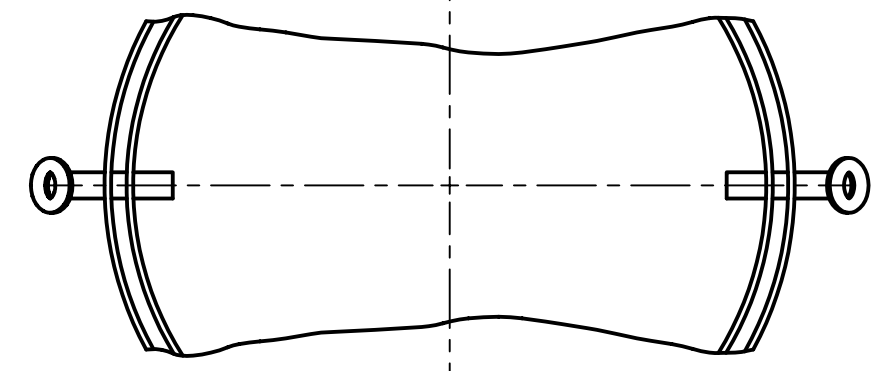
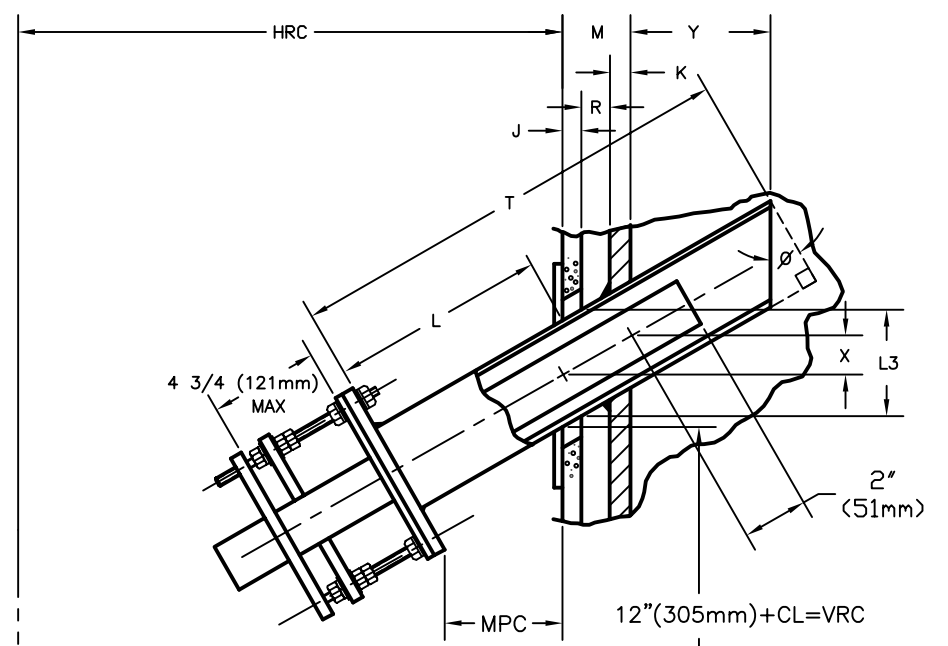
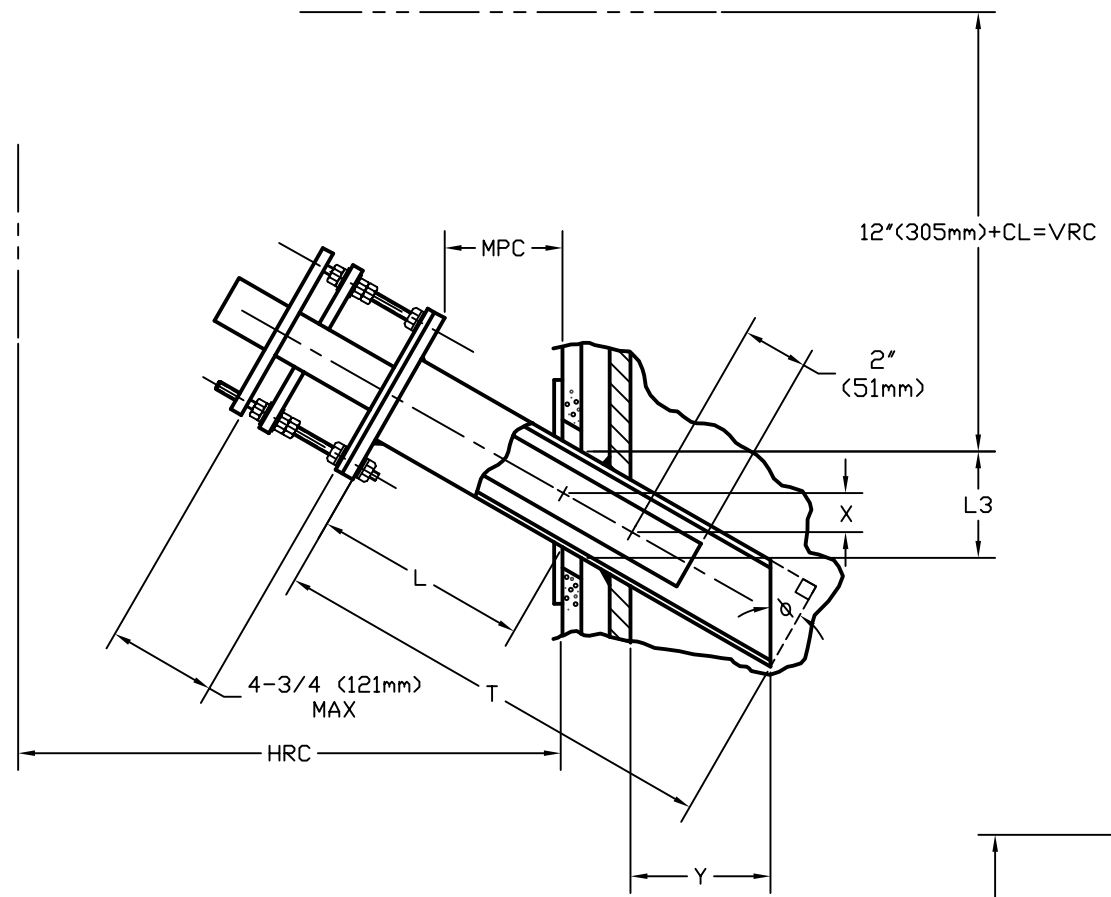

3 H=4'(122cm) OR GREATER, D MUST BE EQ TO OR GREATER THAN H. (DEPENDENT ON MEDIUM CONDITIONS, CONSULT FACTORY). FOR LONG RANGE TRANSDUCER OPTIONS CONSULT FACTORY

2. SEE DRAWING 1900-0002 SHT-4 FOR EQUIPMENT PLACEMENT.
1. SEE DRAWING 1900-0001 FOR NOTES, LETTER DEFINITIONS, AND MTG. PLATE DETAILS.

NOTE: DIMENSIONS IN () ARE METRIC

DIMENSIONAL TOLERANCES <small>UNLESS OTHERWISE SPECIFIED</small> FRACTIONS DECIMALS ANGLES 0 TO 4 41/32 JOK A.M. 40°30' 4 TO 8 41/16 JOK 2.005 RMS FINISH 8 AND UP 41/8 ALL DIMENSIONS ARE IN INCHES DO NOT SCALE THIS DRAWING		USED ON DASH NO. NEXT ASSEMBLY -01	TELEDYNE INSTRUMENTS Monitor Labs A Teledyne Technologies Company <small>THIS DOCUMENT CONTAINS INFORMATION PROPRIETARY AND CONFIDENTIAL TO TELETYPE MONITOR LABS AND IS FURNISHED UNDER THE EXPRESS CONDITION THAT THE INFORMATION CONTAINED HEREIN WILL NOT BE REPRODUCED, REPAIRED, COPIED OR DISSEMINATED TO OTHERS OR USED FOR ANY PURPOSE OTHER THAN IN CONNECTION WITH THE EVALUATION SERVICE WITHOUT THE PRIOR WRITTEN CONSENT OF TELETYPE MONITOR LABS.</small> TITLE ULTRAFLOW 150 FLANGE INSTALLATION X-PATTERN
AUTHORIZATION BY DATE DRAWN EAS 10-25-01 CHECKED EAS Mar-02 DESIGNED EAS Oct-01 ENGINEERED ELM 4-2-02 PRODUCTION PD 4-2-02 G.A. GRG 4/2/02		MAT'L. FINISH	DRAWING NO. D 1900-0006 LATEST REVISION B
PROJECTION		SCALE SHEET NTS 1 OF 1	9-17-02



ACAD2002 FILE 10000006

REVISIONS				
ZONE	SYM.	DESCRIPTION	DATE	APPD.
	A	PER DCN #1901-0008A	9-12-02	ELM
	B	PER DCN #1901-0008B	12-7-06	DMB

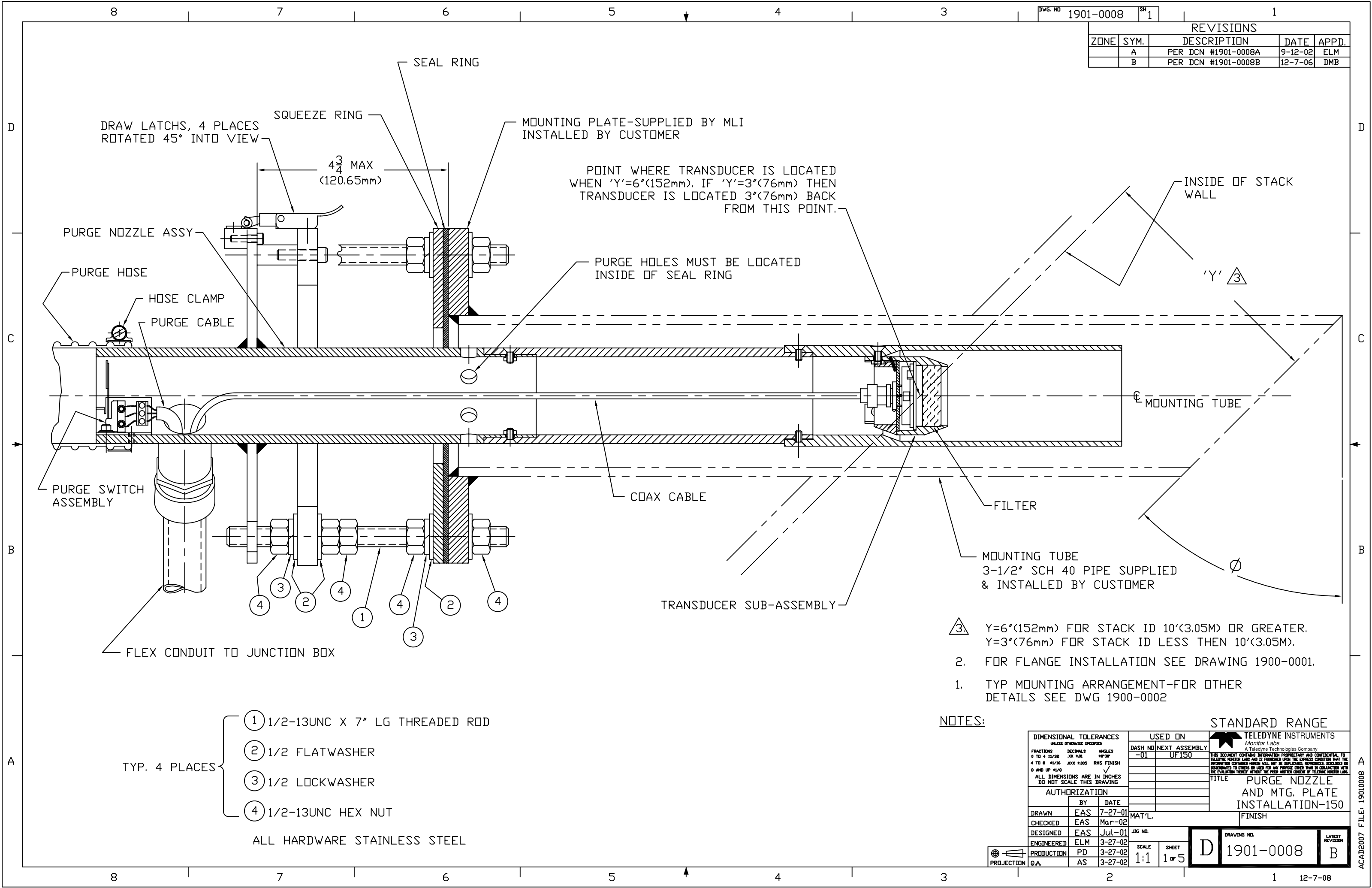

- △ Y=6"(152mm) FOR STACK ID 10'(3.05M) OR GREATER.
 Y=3"(76mm) FOR STACK ID LESS THEN 10'(3.05M).
- FOR FLANGE INSTALLATION SEE DRAWING 1900-0001.
 - TYP MOUNTING ARRANGEMENT-FOR OTHER DETAILS SEE DWG 1900-0002

NOTES:

- TYP. 4 PLACES
- ① 1/2-13UNC X 7" LG THREADED ROD
 - ② 1/2 FLATWASHER
 - ③ 1/2 LOCKWASHER
 - ④ 1/2-13UNC HEX NUT
- ALL HARDWARE STAINLESS STEEL

DIMENSIONAL TOLERANCES UNLESS OTHERWISE SPECIFIED		USED ON		TELEDYNE INSTRUMENTS Monitor Labs A Teledyne Technologies Company	
FRACTIONS	DECIMALS	DASH NO	NEXT ASSEMBLY	THIS DOCUMENT CONTAINS INFORMATION PROPRIETARY AND CONFIDENTIAL TO TELETYPE MONITOR LABS AND IS FURNISHED UNDER THE EXPRESS CONDITION THAT INFORMATION CONTAINED HEREIN WILL NOT BE REPRODUCED, REPRINTER, DISCLOSED OR DISSEMINATED TO OTHERS OR USED FOR ANY PURPOSE OTHER THAN BY COLLECTOR WITH THE EVALUATION HEREOF WITHOUT THE PRIOR WRITTEN CONSENT OF TELETYPE MONITOR LABS.	
0 TO 4 41/32	.001	-01	UF150	TITLE PURGE NOZZLE AND MTG. PLATE INSTALLATION-150	
4 TO 8 41/16	.002			FINISH	
8 AND UP 41/8	.005			DRAWING NO. 1901-0008	
ALL DIMENSIONS ARE IN INCHES DO NOT SCALE THIS DRAWING		AUTHORIZATION		LATEST REVISION B	
		BY	DATE	SCALE 1:1 SHEET 1 OF 5	
		EAS	7-27-01	D 1901-0008	
		EAS	Mar-02	12-7-08	
		EAS	Jul-01		
		ELM	3-27-02		
		PD	3-27-02		
		AS	3-27-02		



REVISIONS				
ZONE	SYM.	DESCRIPTION	DATE	APPD.
	A	NO CHANGE THIS SHEET	9-12-02	ELM
	B	NO CHANGE THIS SHEET	12-7-06	DMB

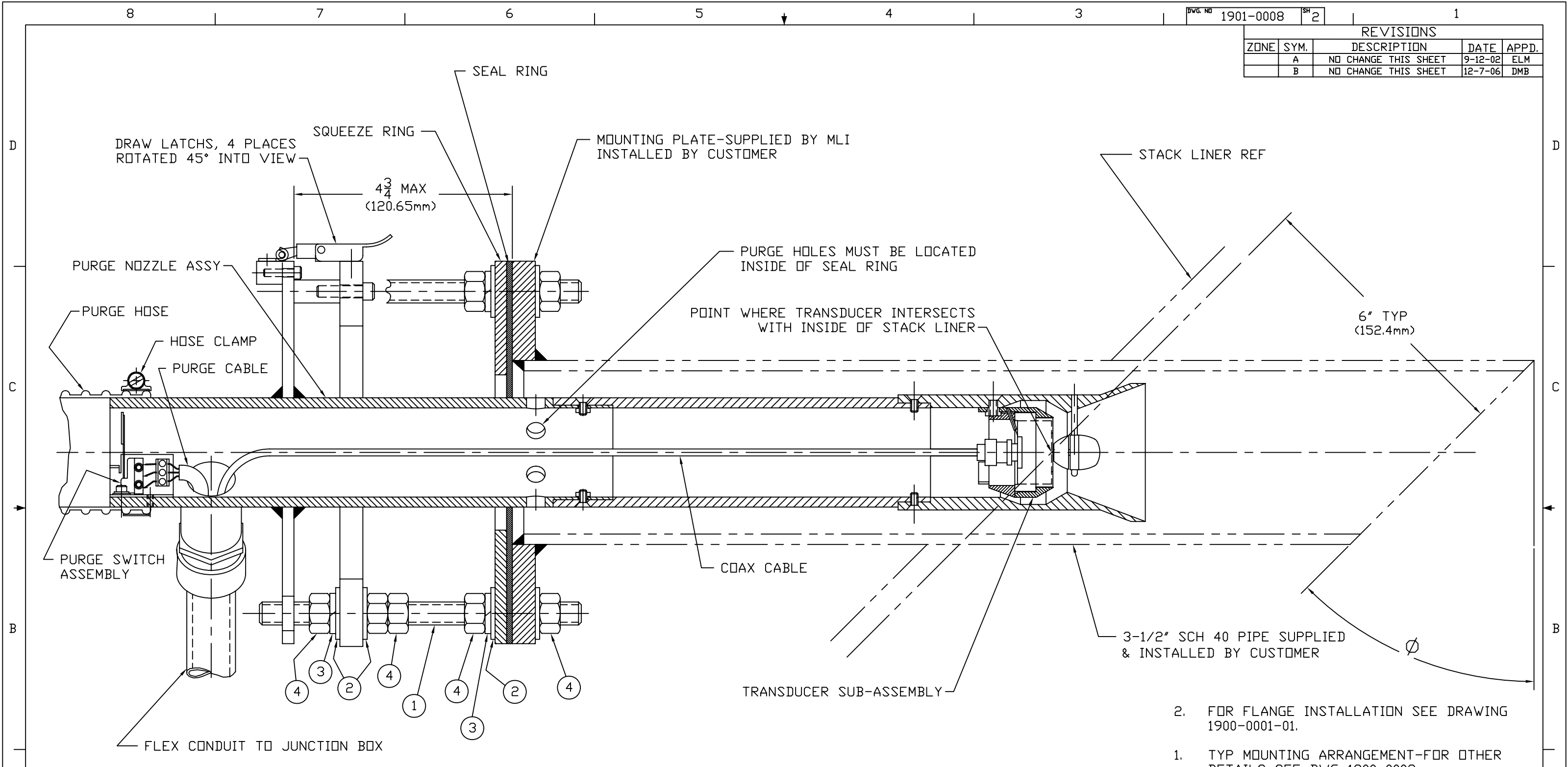

- 2. FOR FLANGE INSTALLATION SEE DRAWING 1900-0001-01.
- 1. TYP MOUNTING ARRANGEMENT-FOR OTHER DETAILS SEE DWG 1900-0002

NOTES:

- ① 1/2-13UNC X 7" LG THREADED ROD
- ② 1/2 FLATWASHER
- ③ 1/2 LOCKWASHER
- ④ 1/2-13UNC HEX NUT

TYP. 4 PLACES

ALL HARDWARE STAINLESS STEEL

LONG RANGE LR003

DIMENSIONAL TOLERANCES UNLESS OTHERWISE SPECIFIED FRACTIONS DECIMALS ANGLES 0 TO 4 41/32 .001 30° 30' 4 TO 8 41/16 .002 RMS FINISH 8 AND UP 41/8 .003		USED ON DASH NO NEXT ASSEMBLY -02 UF150		TELEDYNE INSTRUMENTS Monitor Labs A Teledyne Technologies Company THIS DOCUMENT CONTAINS INFORMATION PROPRIETARY AND CONFIDENTIAL TO TELEDYNE INSTRUMENTS LABS AND IS FURNISHED UNDER THE EXPRESS CONDITION THAT THE INFORMATION CONTAINED HEREIN WILL NOT BE REPRODUCED, REPRINTERED, DISCLOSED OR DISSEMINATED TO OTHERS OR USED FOR ANY PURPOSE OTHER THAN IN CONNECTION WITH THE EVALUATION HEREOF WITHOUT THE PRIOR WRITTEN CONSENT OF TELEDYNE INSTRUMENTS LABS.
AUTHORIZATION BY DATE DRAWN EAS 9-25-01 CHECKED EAS Mar-02 DESIGNED EAS Sept-01 ENGINEERED ELM 4-2-02 PRODUCTION PD 4-2-02 G.A. GRG 4/2/02		MAT'L. FINISH JIG NO. SCALE SHEET 1:1 2 OF 5		
TITLE PURGE NOZZLE AND MTG. PLATE INSTALLATION-150			DRAWING NO. LATEST REVISION D 1901-0008 B	



REVISIONS				
ZONE	SYM.	DESCRIPTION	DATE	APPD.
	A	NO CHANGE THIS SHEET	9-12-02	ELM
	B	NO CHANGE THIS SHEET	12-7-06	DMB

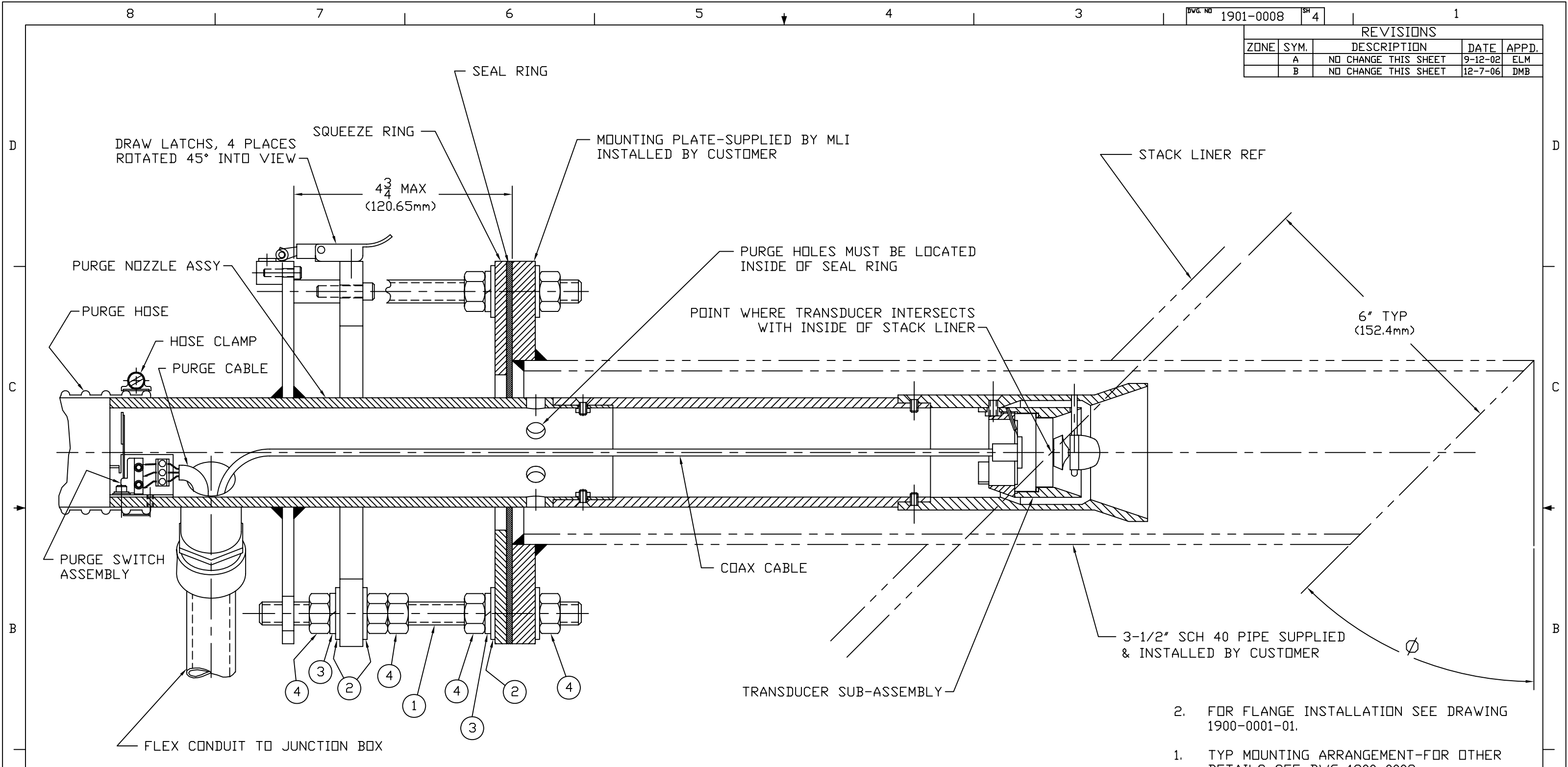

- FOR FLANGE INSTALLATION SEE DRAWING 1900-0001-01.
- TYP MOUNTING ARRANGEMENT-FOR OTHER DETAILS SEE DWG 1900-0002

NOTES:

- ① 1/2-13UNC X 7" LG THREADED ROD
- ② 1/2 FLATWASHER
- ③ 1/2 LOCKWASHER
- ④ 1/2-13UNC HEX NUT

TYP. 4 PLACES

ALL HARDWARE STAINLESS STEEL

LONG RANGE LR005, LR006

DIMENSIONAL TOLERANCES UNLESS OTHERWISE SPECIFIED FRACTIONS DECIMALS ANGLES 0 TO 4 ±1/32 JOK A&I 40°30' 4 TO 8 ±1/16 JOK A&I RNS FINISH 8 AND UP ±1/8 ALL DIMENSIONS ARE IN INCHES DO NOT SCALE THIS DRAWING		USED ON DASH NO NEXT ASSEMBLY -04 UF150		TELEDYNE INSTRUMENTS Monitor Labs A Teledyne Technologies Company THIS DOCUMENT CONTAINS INFORMATION PROPRIETARY AND CONFIDENTIAL TO TELEDYNE INSTRUMENTS LABS AND IS FURNISHED UNDER THE EXPRESS CONDITION THAT THE INFORMATION CONTAINED HEREIN WILL NOT BE REPRODUCED, REPRINTER, DISCLOSED OR DISSEMINATED TO OTHERS OR USED FOR ANY PURPOSE OTHER THAN IN CONNECTION WITH THE EVALUATION HEREOF WITHOUT THE PRIOR WRITTEN CONSENT OF TELEDYNE INSTRUMENTS LABS.	
AUTHORIZATION BY DATE DRAWN EAS 9-25-01 CHECKED EAS Mar-02 DESIGNED EAS Sept-01 ENGINEERED ELM 4-2-02 PRODUCTION PD 4-2-02 G.A. GRG 4/2/02		MAT'L. FINISH JIG NO. SCALE SHEET 1:1 4 OF 5		TITLE PURGE NOZZLE AND MTG. PLATE INSTALLATION-150	
DRAWING NO. 1901-0008			LATEST REVISION B		



REVISIONS				
ZONE	SYM.	DESCRIPTION	DATE	APPD.
	A	NO CHANGE THIS SHEET	9-12-02	ELM
	B	NO CHANGE THIS SHEET	12-7-06	DMB

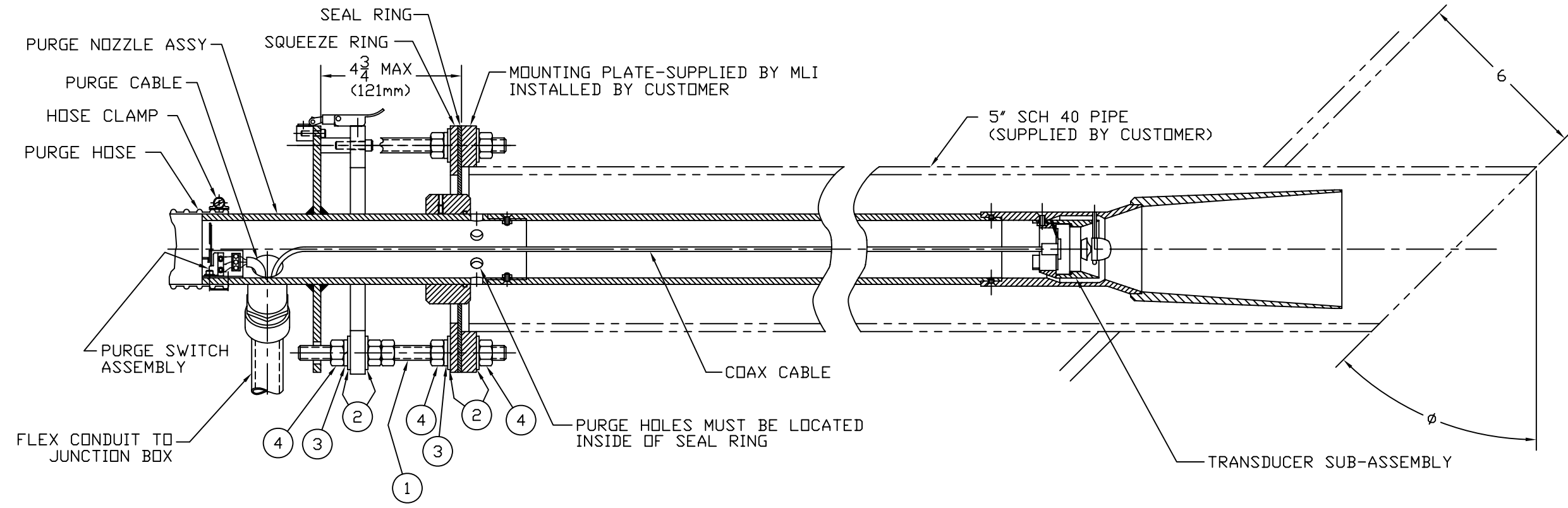

- 2. FOR FLANGE INSTALLATION SEE DRAWING 1900-0001.
- 1. TYP MOUNTING ARRANGEMENT-FOR OTHER DETAILS SEE DWG 1900-0002

NOTES:

- TYP. 4 PLACES
- ① 1/2-13UNC X 7" LG THREADED ROD
 - ② 1/2 FLATWASHER
 - ③ 1/2 LOCKWASHER
 - ④ 1/2-13UNC HEX NUT
- ALL HARDWARE STAINLESS STEEL

LONG RANGE, LR007

DIMENSIONAL TOLERANCES UNLESS OTHERWISE SPECIFIED		USED ON		TELEDYNE INSTRUMENTS Monitor Labs A Teledyne Technologies Company	
FRACTIONS	DECIMALS	DASH NO	NEXT ASSEMBLY	THIS DOCUMENT CONTAINS INFORMATION PROPRIETARY AND CONFIDENTIAL TO TELETYPE MONITOR LABS AND IS FURNISHED UNDER THE EXPRESS CONDITION THAT THE INFORMATION CONTAINED HEREIN WILL NOT BE REPRODUCED, REPRINTERED, DISCLOSED OR DISSEMINATED TO OTHERS OR USED FOR ANY PURPOSE OTHER THAN IN CONNECTION WITH THE EVALUATION HEREOF WITHOUT THE PRIOR WRITTEN CONSENT OF TELETYPE MONITOR LABS.	
0 TO 4 41/32	.001	-05	1000-0000		
4 TO 8 1/16	.002				
8 AND UP 1/8	.005				
ALL DIMENSIONS ARE IN INCHES DO NOT SCALE THIS DRAWING					
AUTHORIZATION					
		BY	DATE		
DRAWN		EAS	10-30-01		
CHECKED		EAS	Mar-02		
DESIGNED		EAS	Oct-01		
ENGINEERED		ELM	4-2-02		
PRODUCTION		PD	4-2-02		
G.A.		GRG	4/2/02		
		MAT'L.		FINISH	
		JIG NO.			
		SCALE	SHEET		
		1/2	5 OF 5		
		DRAWING NO.		LATEST REVISION	
		D 1901-0008		B	



REVISIONS

ZONE	SYM.	DESCRIPTION	DATE	APPD.
A		NO CHANGE THIS SHEET	4-30-02	DMB
B		NO CHANGE THIS SHEET	9-5-02	ELM
C		NO CHANGE THIS SHEET	12-4-03	ELM
D		PER DCN 1903-0000D	4-7-04	DMB
E		NO CHANGE THIS SHEET	2-4-05	DMB
F		NO CHANGE THIS SHEET	7-13-06	DMB
G		PER DCN 1903-0000G	6-1-07	ELM
H		NO CHANGE THIS SHEET	11-30-07	ELM
J		NO CHANGE THIS SHEET	11-24-08	ELM
K		NO CHANGE THIS SHEET	6-21-10	ELM
L		NO CHANGE THIS SHEET	11-15-10	ELM
M		NO CHANGE THIS SHEET	5-12-11	ELM

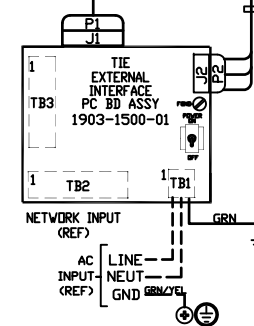
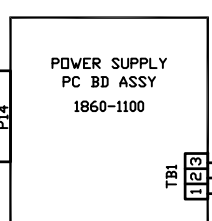
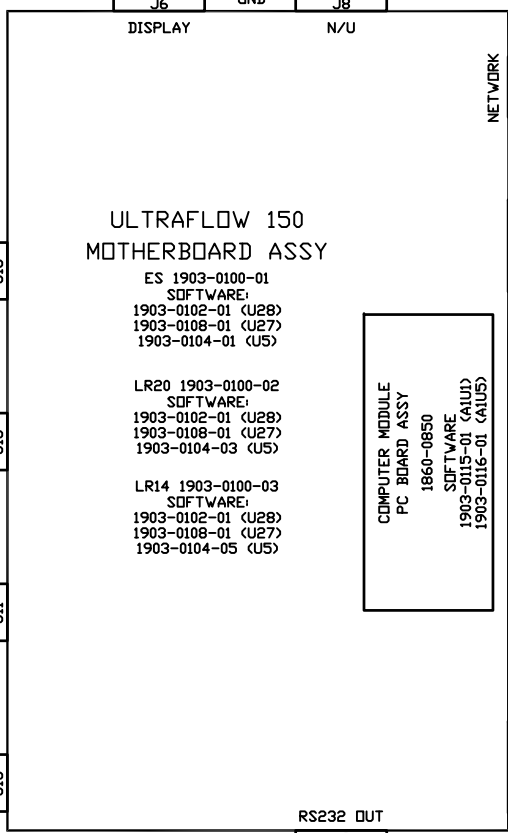
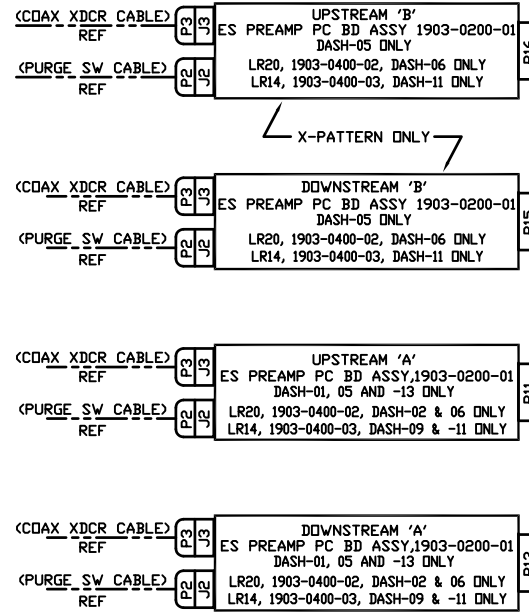
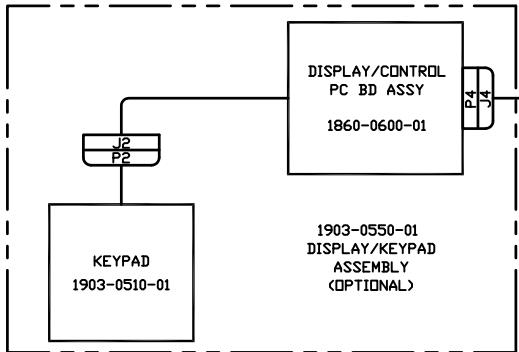

- 13----50 KHz ES STD NO J-BOX
- 11----14 KHz STD X PATTERN
- 09----14 KHz STD
- 06----20 KHz STD X PATTERN
- 05----50 KHz ES STD X PATTERN
- 02----20 KHz STD
- 01----50 KHz ES STD

NOTE: 'STD.' INDICATES TML REMOTE DEVICE AND LONWORKS CABLING USED. FOR DIRECT INTERFACE WIRING, SEE SHT. 4.

DIMENSIONAL TOLERANCES UNLESS OTHERWISE SPECIFIED		USED ON		TELEDYNE MONITOR LABS A Teledyne Technologies Company	
FRACTION	DECIMAL	DASH	NEXT ASSEMBLY	<p>THIS DRAWING CONTAINS TELETYPE TRANSMISSIONS AND TELETYPE RECEIPTS. THESE TRANSMISSIONS AND RECEIPTS ARE THE PROPERTY OF THE COMPANY AND ARE TO BE KEPT IN THE COMPANY'S FILES. ANY REPRODUCTION OR DISTRIBUTION OF THESE TRANSMISSIONS OR RECEIPTS WITHOUT THE WRITTEN PERMISSION OF THE COMPANY IS STRICTLY PROHIBITED.</p> <p>TITLE: TRANSducer INTERFACE ENCLOSURE STD. WIRING DIAGRAM</p>	
0 TO 4	0.005	01			
4 TO 8	0.005	02			
8 TO 16	0.005	05			
16 TO 32	0.005	06			
32 TO 64	0.005	09			
64 TO 128	0.005	11			
128 TO 256	0.005	13			
ALL DIMENSIONS ARE IN INCHES UNLESS OTHERWISE SPECIFIED. DO NOT SCALE THIS DRAWING.					
AUTHORIZATION		MATERIAL		FINISH	
BY	DATE				
DRAWN	DCH 7-9-01				
CHECKED	EAS MAR-02				
DESIGNED	DCH 8-30-01				
ENGINEERED	ELM 3-21-02				
PRODUCTION	PD 3-22-02				
PROJECTION	AS 3-22-02				
SCALE		SHEET		DRAWING NO.	
-		3 of 4		D 1903-0000	
				M	

RTD INPUT
4-20ma INPUT
4-20ma INPUT



REVISIONS

ZONE	SYM.	DESCRIPTION	DATE	APPD.
A		NO CHANGE THIS SHEET	4-30-02	DMB
B		NO CHANGE THIS SHEET	9-5-02	ELM
C		NO CHANGE THIS SHEET	12-4-03	ELM
D		PER DCN 1903-0000	4-7-04	DMB
E		NO CHNGE THIS SHEET	2-4-05	DMB
F		NO CHANGE THIS SHEET	7-13-06	DMB
G		PER DCN 1903-0000G	6-1-07	ELM
H		NO CHANGE THIS SHEET	11-30-07	ELM
J		NO CHANGE THIS SHEET	11-24-07	ELM
K		NO CHANGE THIS SHEET	7-9-10	ELM
L		NO CHANGE THIS SHEET	11-15-10	ELM
M		NO CHANGE THIS SHEET	5-12-11	ELM

- 14----50 KHz ES DIRECT INTERFACE NO J-BDX
- 12----14 KHz DIRECT INTERFACE X PATTERN
- 10----14 KHz DIRECT INTERFACE
- 08----20 KHz DIRECT INTERFACE X PATTERN
- 07----50 KHz ES DIRECT INTERFACE X PATTERN
- 04----20 KHz DIRECT INTERFACE
- 03----50 KHz ES DIRECT INTERFACE

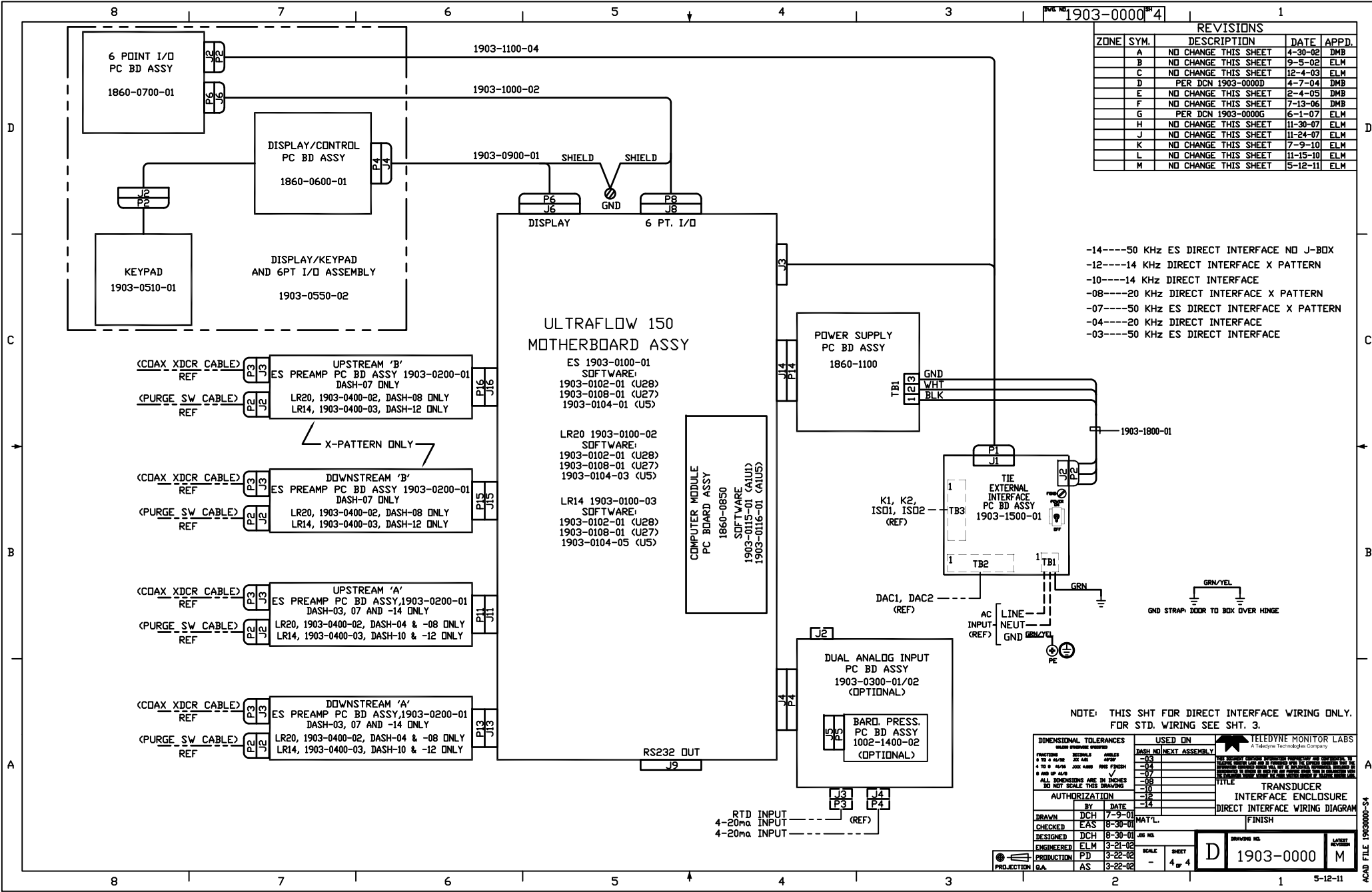

NOTE: THIS SHT FOR DIRECT INTERFACE WIRING ONLY. FOR STD. WIRING SEE SHT. 3.

DIMENSIONAL TOLERANCES UNLESS OTHERWISE SPECIFIED		USED ON		TELEDYNE MONITOR LABS A Teledyne Technologies Company	
FRACTION	DECIMAL	DASH NO	NEXT ASSEMBLY	TITLE	FINISH
0 TO 4 mm	0.05	-03		TRANSducer	
4 TO 6 mm	0.075	-14		INTERFACE ENCLOSURE	
6 TO 8 mm	0.10	-07		DIRECT INTERFACE WIRING DIAGRAM	
8 mm UP	0.15	-10			
ALL DIMENSIONS ARE IN INCHES		-12			
DO NOT SCALE THESE DRAWINGS		-14			

AUTHORIZATION		MATERIAL	
BY	DATE	BY	DATE
DCH	7-9-01		
EAS	8-30-01		
DCH	8-30-01		
ELM	3-21-02		
PD	3-22-02		
AS	3-22-02		

SCALE	SHEET	DRWING NO.	LAST REVISED
4 in 4	4 of 4	1903-0000	M

REVISIONS				
ZONE	SYM.	DESCRIPTION	DATE	APPD.
	A	PER DCN #1903-0010A	6-21-02	DMB
	B	PER DCN #1903-0010B	2-25-04	ELM

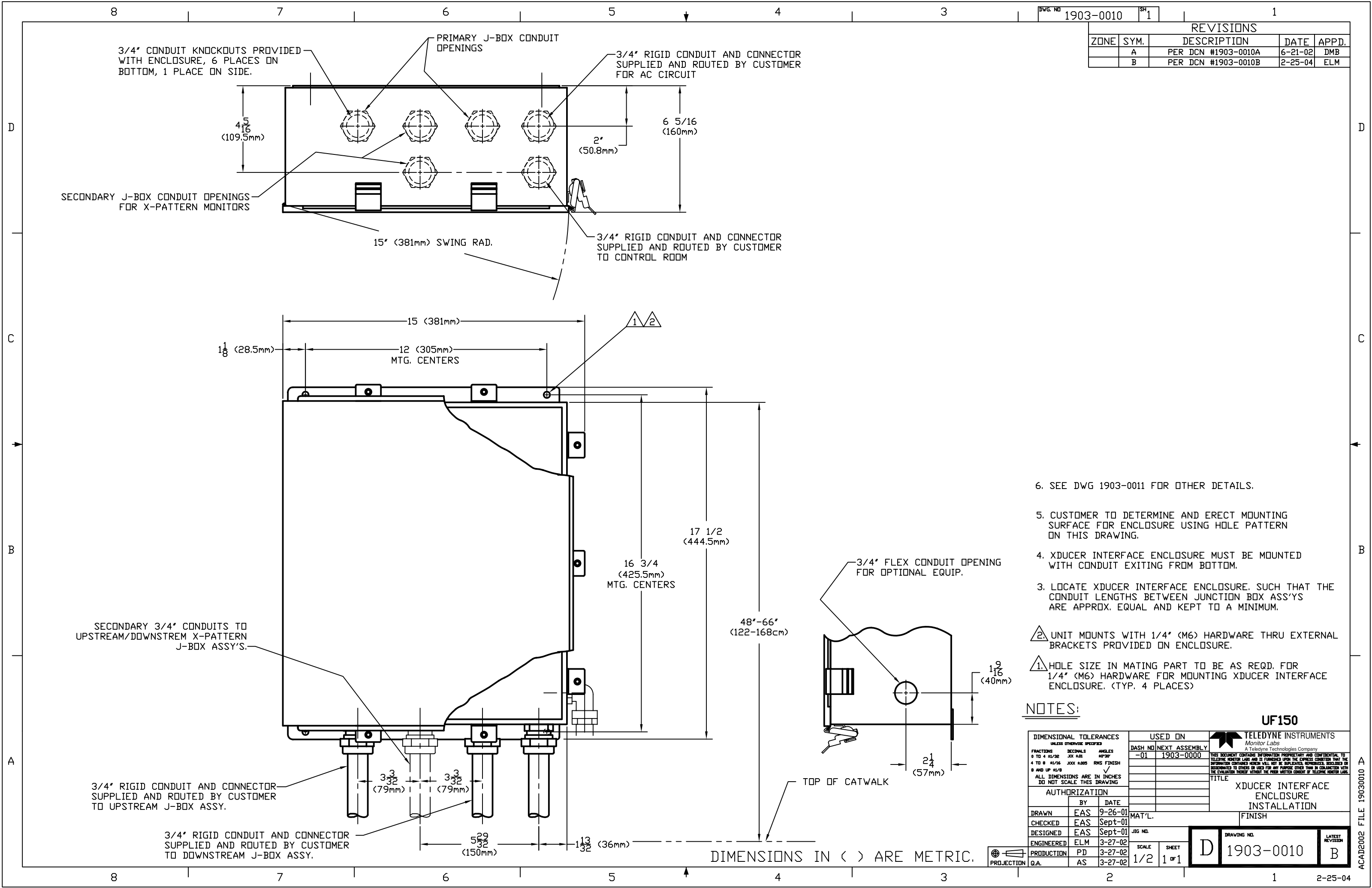

- SEE DWG 1903-0011 FOR OTHER DETAILS.
 - CUSTOMER TO DETERMINE AND ERECT MOUNTING SURFACE FOR ENCLOSURE USING HOLE PATTERN ON THIS DRAWING.
 - XDUCER INTERFACE ENCLOSURE MUST BE MOUNTED WITH CONDUIT EXITING FROM BOTTOM.
 - LOCATE XDUCER INTERFACE ENCLOSURE, SUCH THAT THE CONDUIT LENGTHS BETWEEN JUNCTION BOX ASS'YS ARE APPROX. EQUAL AND KEPT TO A MINIMUM.
- UNIT MOUNTS WITH 1/4" (M6) HARDWARE THRU EXTERNAL BRACKETS PROVIDED ON ENCLOSURE.
- HOLE SIZE IN MATING PART TO BE AS REQD. FOR 1/4" (M6) HARDWARE FOR MOUNTING XDUCER INTERFACE ENCLOSURE. (TYP. 4 PLACES)

NOTES:

UF150

DIMENSIONAL TOLERANCES UNLESS OTHERWISE SPECIFIED FRACTIONS DECIMALS ANGLES 0 TO 4 41/32 JOK A&I 40°30' 4 TO 8 41/16 JOK 2.005 RMS FINISH 8 AND UP 41/8 ALL DIMENSIONS ARE IN INCHES DO NOT SCALE THIS DRAWING		USED ON DASH NO NEXT ASSEMBLY -01 1903-0000		TELEDYNE INSTRUMENTS Monitor Labs A Teledyne Technologies Company THIS DOCUMENT CONTAINS INFORMATION PROPRIETARY AND CONFIDENTIAL TO TELEPHONE MONITOR LABS AND IS FURNISHED UNDER THE EXPRESS CONDITION THAT THE INFORMATION CONTAINED HEREIN WILL NOT BE REPRODUCED, REPARATED, DISCLOSED OR DISSEMINATED TO OTHERS OR USED FOR ANY PURPOSE OTHER THAN IN CONNECTION WITH THE EVALUATION HEREOF WITHOUT THE PRIOR WRITTEN CONSENT OF TELEPHONE MONITOR LABS.	
AUTHORIZATION BY DATE DRAWN EAS 9-26-01 CHECKED EAS Sept-01 DESIGNED EAS Sept-01 ENGINEERED ELM 3-27-02 PRODUCTION PD 3-27-02 Q.A. AS 3-27-02		MAT'L. FINISH		TITLE XDUCER INTERFACE ENCLOSURE INSTALLATION	
SCALE SHEET 1/2 1 OF 1		DRAWING NO. D 1903-0010		LATEST REVISION B	

DIMENSIONS IN () ARE METRIC.



ACAD2002 FILE 19030010

REVISIONS				
ZONE	SYM.	DESCRIPTION	DATE	APPD.
	A	ADDED THIS SHEET PER DCN #1903-0011A	11-25-03	ELM
	B	PER DCN #1903-0011B	2-25-04	ELM
	C	PER DCN #1903-0011C	4-24-07	

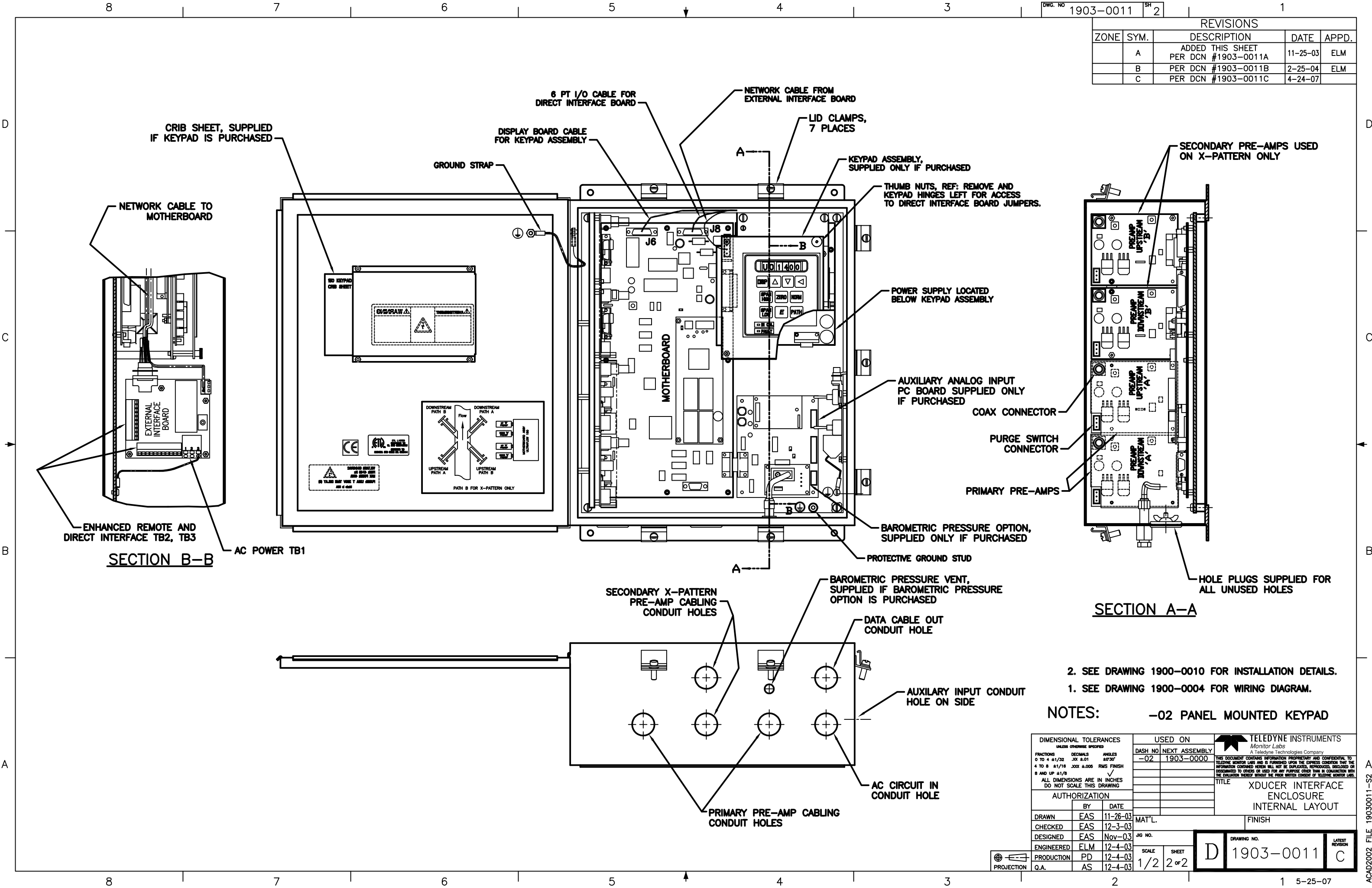

SECTION B-B

SECTION A-A

2. SEE DRAWING 1900-0010 FOR INSTALLATION DETAILS.
 1. SEE DRAWING 1900-0004 FOR WIRING DIAGRAM.

NOTES: -02 PANEL MOUNTED KEYPAD

DIMENSIONAL TOLERANCES UNLESS OTHERWISE SPECIFIED FRACTIONS DECIMALS ANGLES 0 TO 4 ±1/32 .001 ±.01 30°/30' 4 TO 8 ±1/16 .002 ±.005 RMS FINISH 8 AND UP ±1/8 ALL DIMENSIONS ARE IN INCHES DO NOT SCALE THIS DRAWING		USED ON DASH NO NEXT ASSEMBLY -02 1903-0000		TELEDYNE INSTRUMENTS Monitor Labs A Teledyne Technologies Company THIS DOCUMENT CONTAINS INFORMATION PROPRIETARY AND CONFIDENTIAL TO TELEDYNE INSTRUMENTS LABS AND IS FURNISHED UNDER THE EXPRESS CONDITION THAT THE INFORMATION CONTAINED HEREIN WILL NOT BE DUPLICATED, REPRODUCED, DISCLOSED OR DISSEMINATED TO OTHERS OR USED FOR ANY PURPOSE OTHER THAN IN CONNECTION WITH THE EVALUATION THEREOF WITHOUT THE PRIOR WRITTEN CONSENT OF TELEDYNE INSTRUMENTS LABS.	
AUTHORIZATION BY DATE DRAWN EAS 11-26-03 CHECKED EAS 12-3-03 DESIGNED EAS Nov-03 ENGINEERED ELM 12-4-03 PRODUCTION PD 12-4-03 Q.A. AS 12-4-03		MAT'L. JIG NO. SCALE SHEET 1/2 2 OF 2		TITLE XDUCER INTERFACE ENCLOSURE INTERNAL LAYOUT FINISH	
PROJECTION		DRAWING NO. D 1903-0011		LATEST REVISION C	

REVISIONS				
ZONE	SYM.	DESCRIPTION	DATE	APPD.
	B	REDRAWN ON CADD	7-10-92	EAS
	C	PER ECN #1004-0008B	11-18-95	EAS
	D	PER ECN #1004-0008C	7-19-95	EAS
	E	PER ECN #1004-0008E	1-22-96	EAS
	F	NO CHANGE THIS SHEET	8-20-98	EAS
	G	PER DCN #1004-0008G	2-2-99	ELM
	H	PER DCN #1004-0008H	4-18-00	ELM
	J	PER DCN #1004-0008J	7-13-05	ELM

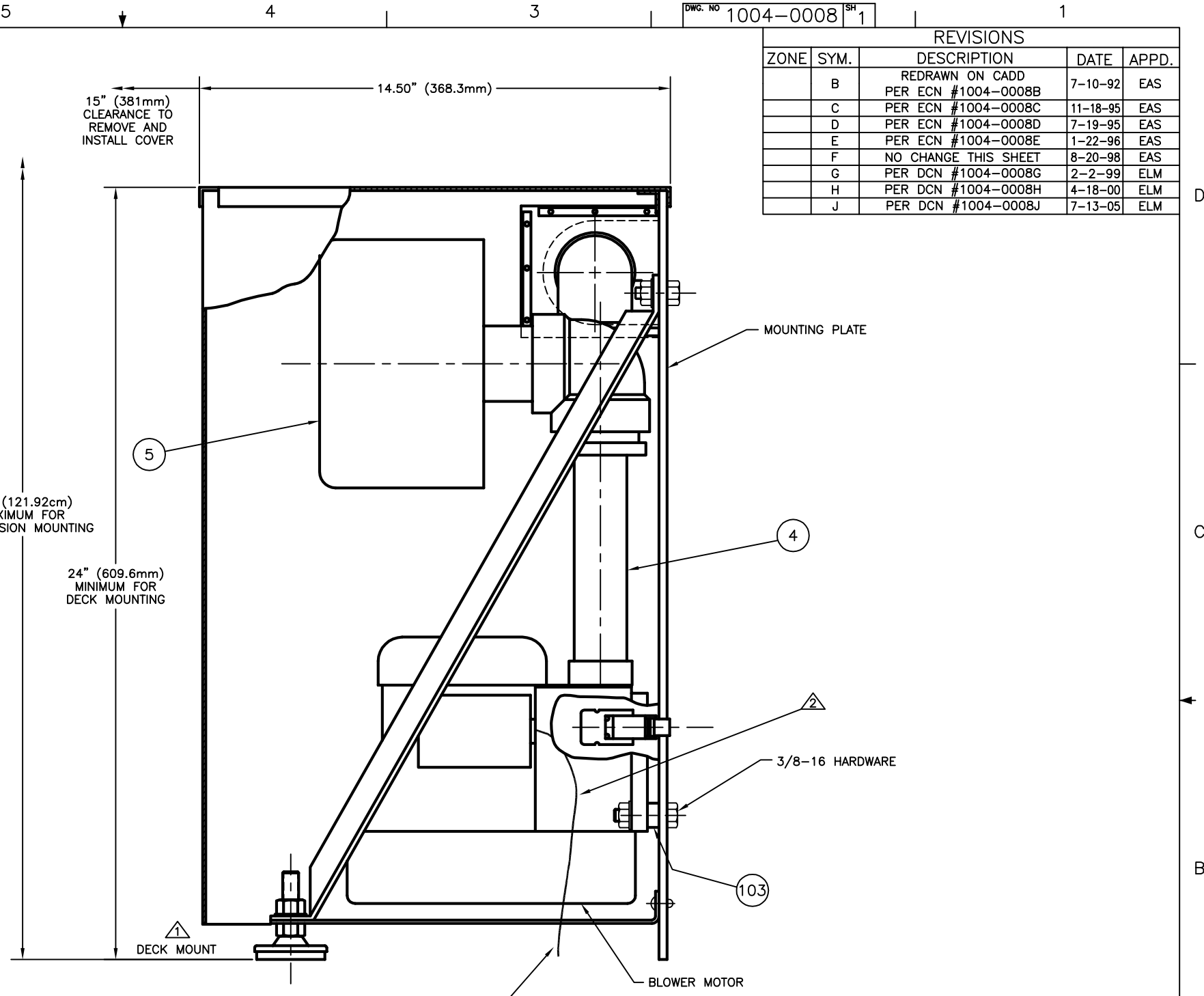
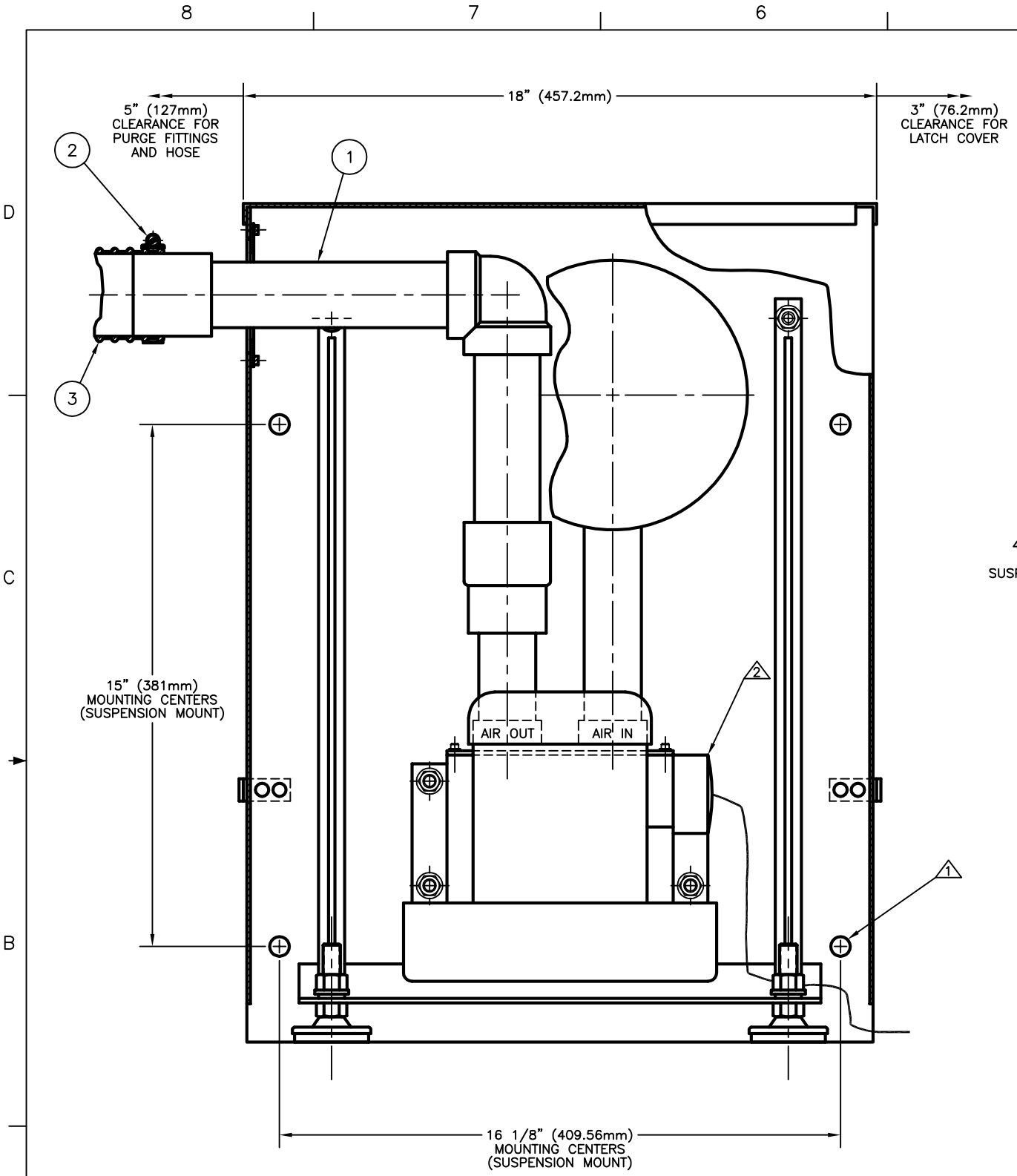

- ① OUTLET PLUMBING (PARTIALLY ASSEMBLED) ATTACHES TO NPT THREAD, MOUNTED ON AIR OUTLET
- ② ADJUSTABLE HOSE CLAMP
- ③ PURGE HOSE
- ④ INLET PLUMBING, ATTACHES TO NPT THREAD MOUNTED ON AIR INLET.
- ⑤ AIR FILTER WITH ELEMENT THREADS INTO INLET PLUMBING.
- ⑩ SPACERS, 4 PLACES

ASSEMBLY PROCEDURE:
 1. ATTACH INLET PLUMBING TO BLOWER.
 2. ATTACH EXHAUST PLUMBING TO BLOWER.
 3. INSTALL FILTER IT-5 ONTO INLET PLUMBING.
 4. INSTALL BLOWER TO BACK PLATE. MAKE SURE SPACERS IT-103 ARE UNDER BLOWER.

AC SERVICE ENTRANCE CABLE & STRAIN RELIEF TO BE SUPPLIED BY CUSTOMER.

△ CUSTOMER TO SUPPLY AND HARDWIRE AC CIRCUIT TO MOTOR J-BOX USING 1/2" SERVICE ENTRANCE AND WATER TIGHT CONNECTORS.

△ UNIT MAYBE DECK MOUNTED (FREE STANDING) OR MOUNTED IN SUSPENSION USING 1/2" (M12) HARDWARE, THRU THE MOUNTING HOLES PROVIDED.

NOTES:

DIMENSIONAL TOLERANCES UNLESS OTHERWISE SPECIFIED FRACTIONS DECIMALS ANGLES 0 TO 4 ±1/32 .001 ±.01 ±0°30' 4 TO 8 ±1/16 .002 ±.005 RMS FINISH 8 AND UP ±1/8 ALL DIMENSIONS ARE IN INCHES DO NOT SCALE THIS DRAWING		USED ON DASH NO NEXT ASSEMBLY -01 1000-0000		TELEDYNE MONITOR LABS A Teledyne Technologies Company THIS DOCUMENT CONTAINS INFORMATION PROPRIETARY AND CONFIDENTIAL TO TELEDYNE MONITOR LABS AND IS FURNISHED UNDER THE EXPRESS CONDITION THAT THE INFORMATION CONTAINED HEREIN WILL NOT BE DUPLICATED, REPRODUCED, DISCLOSED OR DISSEMINATED TO OTHERS OR USED FOR ANY PURPOSE OTHER THAN IN CONNECTION WITH THE EVALUATION THEREOF WITHOUT THE PRIOR WRITTEN CONSENT OF TELEDYNE MONITOR LABS.	
AUTHORIZATION BY DATE DRAWN EAS 7-10-92 CHECKED WLS 12-26-91 DESIGNED EAS Feb-02 ENGINEERED JET 12-26-91 PRODUCTION PJY 12-26-91 Q.A. GRG 12-26-91		MAT'L. FINISH		TITLE PURGE ASSY MTG, PLUMBING & CLEARANCE REQUIREMENTS	
SCALE NTS SHEET 1 OF 2		DRAWING NO. D 1004-0008 LATEST REVISION J		7-13-05	

DIMENSIONS IN () ARE METRIC.



REVISIONS			
SYM.	DESCRIPTION	DATE	APPD.
A	PER DCN #1904-0000A	6-27-02	ELM

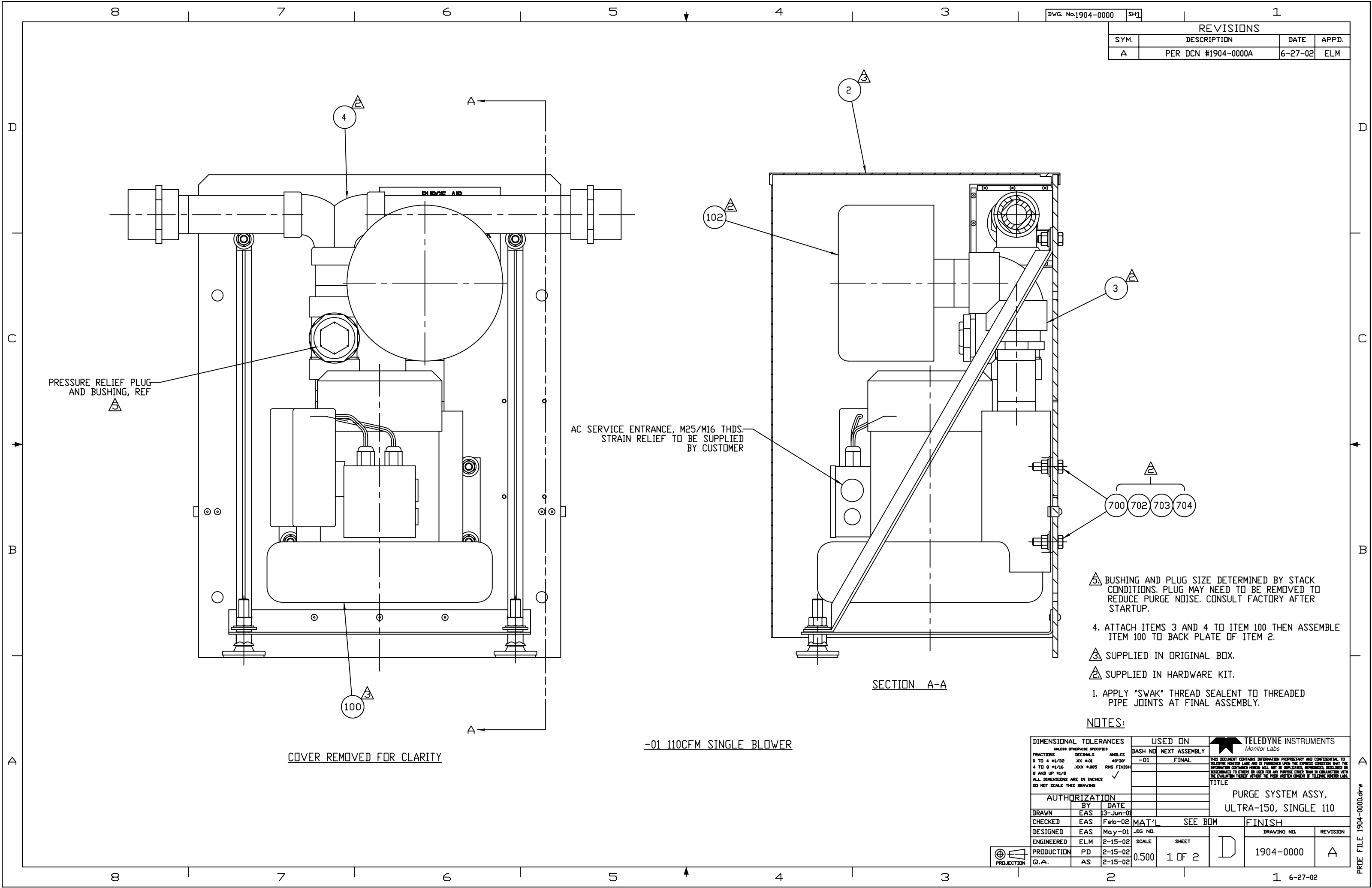

AC SERVICE ENTRANCE, M25/M16 THDS.
STRAIN RELIEF TO BE SUPPLIED
BY CUSTOMER

SECTION A-A

- NOTES:
- ▲ BUSHING AND PLUG SIZE DETERMINED BY STACK CONDITIONS. PLUG MAY NEED TO BE REMOVED TO REDUCE PURGE NOISE. CONSULT FACTORY AFTER STARTUP.
 - 4. ATTACH ITEMS 3 AND 4 TO ITEM 100 THEN ASSEMBLE ITEM 100 TO BACK PLATE OF ITEM 2.
 - ▲ SUPPLIED IN ORIGINAL BOX.
 - ▲ SUPPLIED IN HARDWARE KIT.
 - 1. APPLY *SWAK* THREAD SEALANT TO THREADED PIPE JOINTS AT FINAL ASSEMBLY.

COVER REMOVED FOR CLARITY

-01 110CFM SINGLE BLOWER

DIMENSIONAL TOLERANCES UNLESS OTHERWISE SPECIFIED			USED ON		TELEDYNE INSTRUMENTS Monitor Labs
FRACTIONS	DECIMALS	ANGLES	DASH NO	NEXT ASSEMBLY	
0 TO 4 #1/32	.005	±30°	-01	FINAL	THIS DOCUMENT CONTAINS INFORMATION PROPRIETARY AND CONFIDENTIAL TO TELEDYNE INSTRUMENT LABS AND IS FURNISHED UPON THE EXPRESS CONDITION THAT THE INFORMATION CONTAINED HEREIN WILL NOT BE REPRODUCED, COPIED OR DISSEMINATED TO OTHERS OR USED FOR ANY PURPOSE OTHER THAN IN CONNECTION WITH THE EVALUATION THEREOF WITHOUT THE PRIOR WRITTEN CONSENT OF TELEDYNE INSTRUMENT LABS.
4 TO 8 #1/16	.010	±30°			
8 AND UP #1/8	.015	±30°			TITLE
ALL DIMENSIONS ARE IN INCHES DO NOT SCALE THIS DRAWING					PURGE SYSTEM ASSY, ULTRA-150, SINGLE 110
AUTHORIZATION					
BY	EAS	DATE	3-Jun-01		
CHECKED	EAS	DATE	Feb-02		
DESIGNED	EAS	DATE	May-01		
ENGINEERED	ELM	DATE	2-15-02		
PRODUCTION	PD	DATE	2-15-02		
Q.A.	AS	DATE	2-15-02		
MATERIAL			SEE BOM	FINISH	
SCALE			0.500	SHEET	
				1 OF 2	
DRAWING NO.			1904-0000	REVISION	A

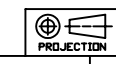

REVISIONS			
SYM.	DESCRIPTION	DATE	APPD.
A	NO CHANGE THIS SHEET	6-27-02	ELM

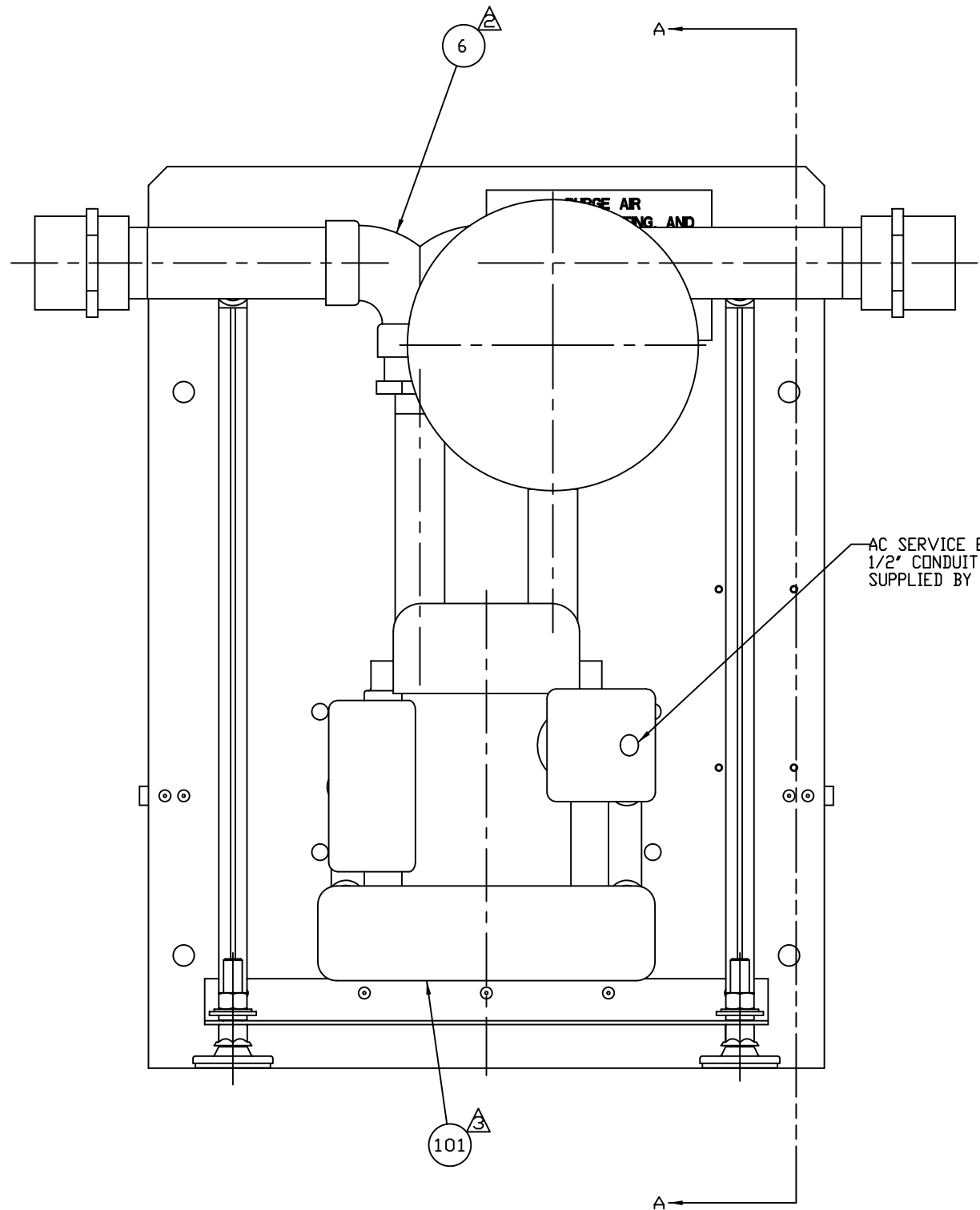

COVER REMOVED FOR CLARITY

AC SERVICE ENTRANCE ON FAR SIDE,
1/2" CONDUIT KNOCKOUT. STRAIN RELIEF
SUPPLIED BY CUSTOMER

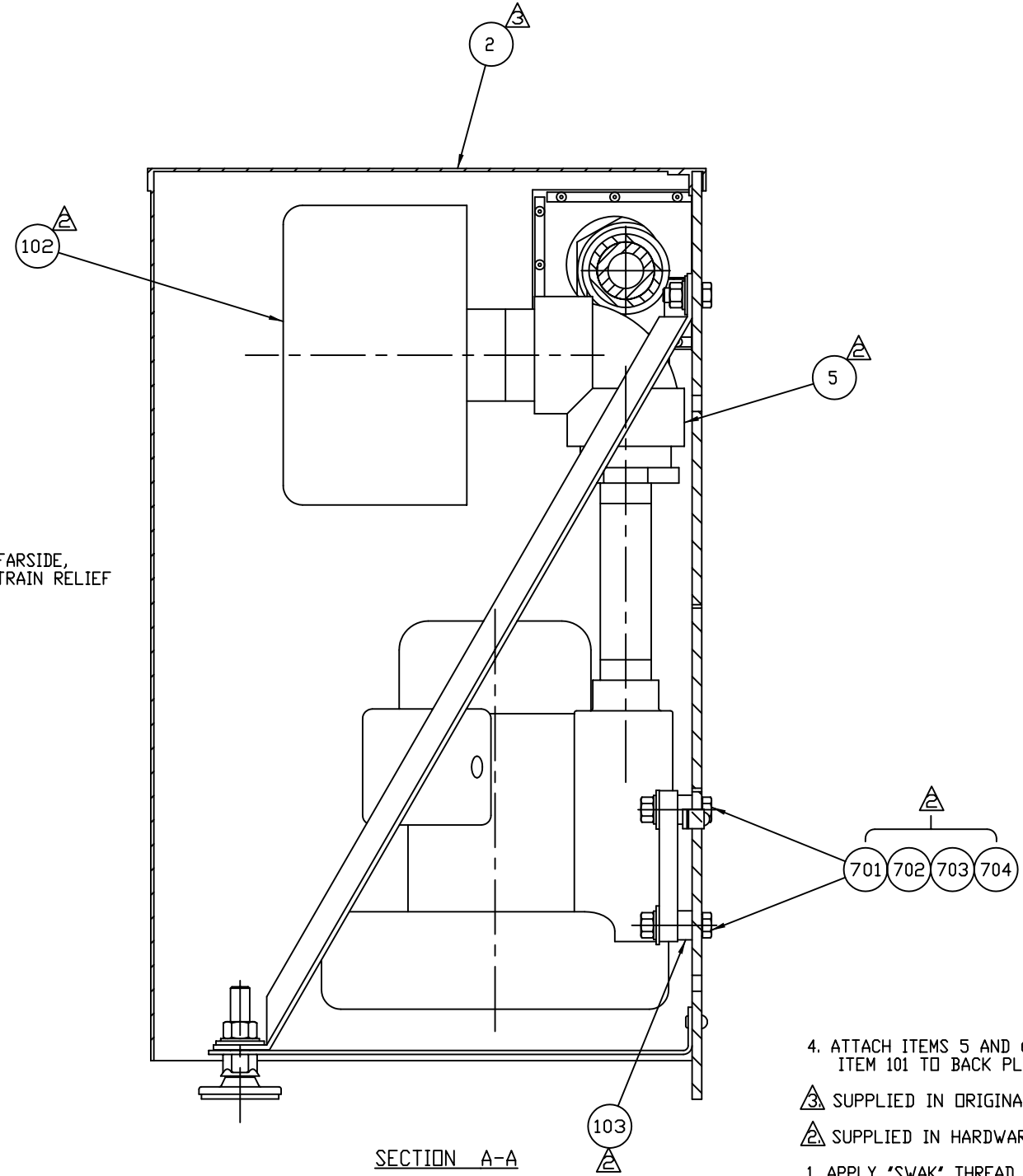

SECTION A-A

4. ATTACH ITEMS 5 AND 6 TO ITEM 101 THEN ASSEMBLE
ITEM 101 TO BACK PLATE OF ITEM 2.

⊕ SUPPLIED IN ORIGINAL BOX.

⊗ SUPPLIED IN HARDWARE KIT.

1. APPLY 'SWAK' THREAD SEALANT TO THREADED
PIPE JOINTS AT FINAL ASSEMBLY.

NOTES:

-02 42CFM SINGLE BLOWER

<small>DIMENSIONAL TOLERANCES UNLESS OTHERWISE SPECIFIED</small> FRACTIONS DECIMALS ANGLES 0 TO $4 \frac{1}{32}$.001 .001 4 TO $8 \frac{1}{16}$.002 .002 8 AND UP $1/8$.005 .005 <small>ALL DIMENSIONS ARE IN INCHES DO NOT SCALE THIS DRAWING</small>			<small>USED ON</small> DASH NO. NEXT ASSEMBLY -02 FINAL		TELEDYNE INSTRUMENTS Monitor Labs <small>THIS DOCUMENT CONTAINS INFORMATION PROPRIETARY AND CONFIDENTIAL TO TELEDYNE INSTRUMENTS LABS AND IS FURNISHED UPON THE EXPRESS CONDITION THAT THE INFORMATION CONTAINED HEREIN WILL NOT BE REPLICATED, REPRODUCED, DISCLOSED OR DISSEMINATED TO OTHERS OR USED FOR ANY PURPOSE OTHER THAN IN CONNECTION WITH THE EVALUATION THEREOF WITHOUT THE WRITTEN CONSENT OF TELEDYNE INSTRUMENTS LABS.</small>
<small>AUTHORIZATION</small> BY DATE EAS 13-Jun-01			TITLE PURGE SYSTEM ASSY, ULTRA-150, SINGLE 42		
<small>DRAWN</small> EAS <small>CHECKED</small> EAS <small>DESIGNED</small> EAS <small>ENGINEERED</small> ELM <small>PRODUCTION</small> PD <small>Q.A.</small> AS	<small>DATE</small> 13-Jun-01 Feb-02 May-01 2-15-02 2-15-02 2-15-02	<small>MAT'L</small> SEE BOM <small>JIG NO.</small> FINISH SCALE 0.500 <small>SHEET</small> 2 OF 2	<small>DRAWING NO.</small> 1904-0000	<small>REVISION</small> A	<small>DATE</small> 6-27-02

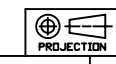

PRUE FILE 1904-0000.drw

REVISIONS				
ZONE	SYM.	DESCRIPTION	DATE	APPD.
	A	PER DCN #1906-0010A	1-8-03	DMB

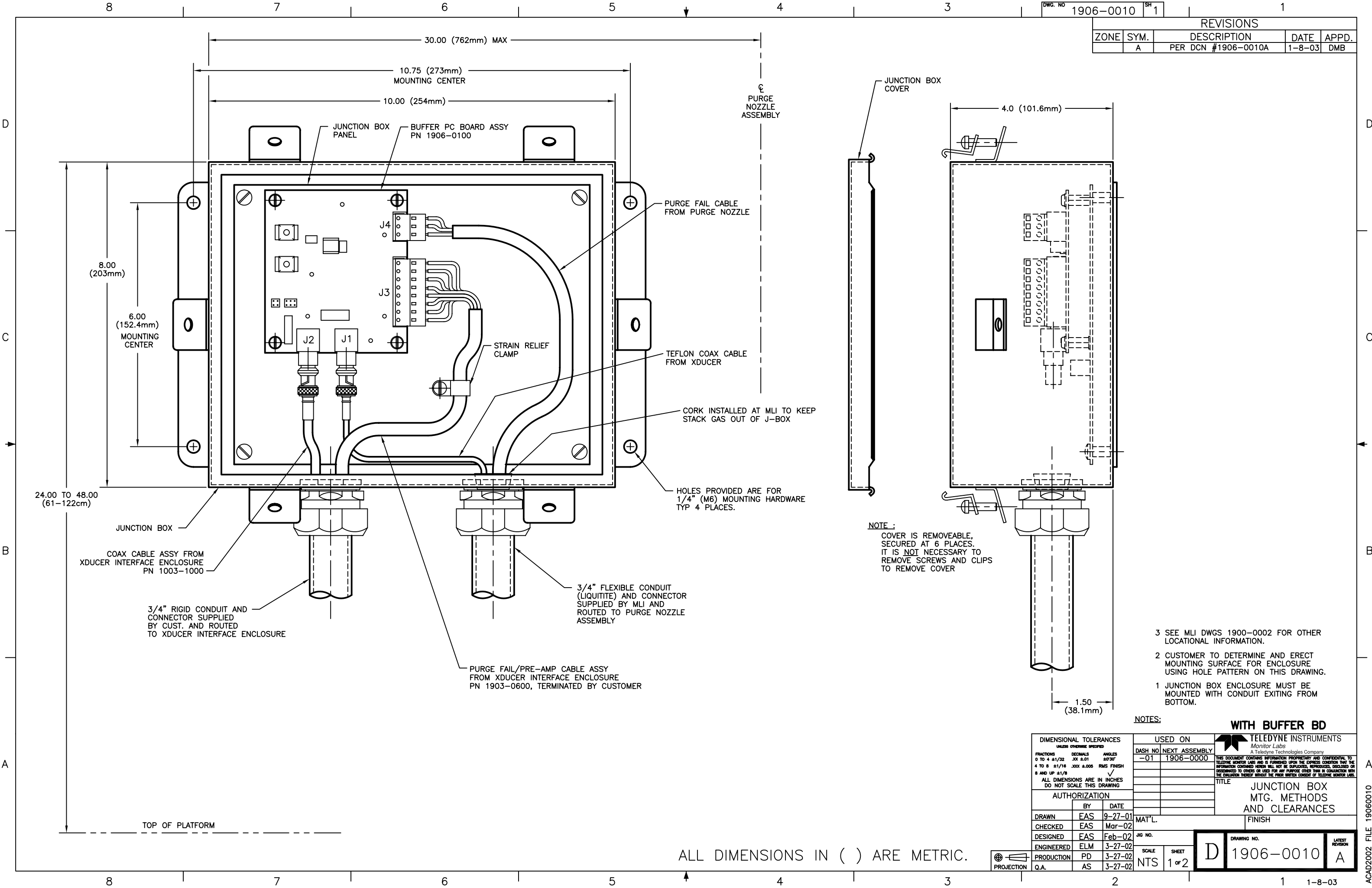

24.00 TO 48.00
(61-122cm)

8.00
(203mm)

6.00
(152.4mm)
MOUNTING
CENTER

30.00 (762mm) MAX

10.75 (273mm)
MOUNTING CENTER

10.00 (254mm)

JUNCTION BOX
PANEL

BUFFER PC BOARD ASSY
PN 1906-0100

PURGE
NOZZLE
ASSEMBLY

PURGE FAIL CABLE
FROM PURGE NOZZLE

STRAIN RELIEF
CLAMP

TEFLON COAX CABLE
FROM XDUCER

CORK INSTALLED AT MLI TO KEEP
STACK GAS OUT OF J-BOX

HOLES PROVIDED ARE FOR
1/4" (M6) MOUNTING HARDWARE
TYP 4 PLACES.

COAX CABLE ASSY FROM
XDUCER INTERFACE ENCLOSURE
PN 1003-1000

3/4" RIGID CONDUIT AND
CONNECTOR SUPPLIED
BY CUST. AND ROUTED
TO XDUCER INTERFACE ENCLOSURE

3/4" FLEXIBLE CONDUIT
(LIQUITITE) AND CONNECTOR
SUPPLIED BY MLI AND
ROUTED TO PURGE NOZZLE
ASSEMBLY

PURGE FAIL/PRE-AMP CABLE ASSY
FROM XDUCER INTERFACE ENCLOSURE
PN 1903-0600, TERMINATED BY CUSTOMER

NOTE :
COVER IS REMOVEABLE,
SECURED AT 6 PLACES.
IT IS NOT NECESSARY TO
REMOVE SCREWS AND CLIPS
TO REMOVE COVER

- 3 SEE MLI DWGS 1900-0002 FOR OTHER LOCALATIONAL INFORMATION.
- 2 CUSTOMER TO DETERMINE AND ERECT MOUNTING SURFACE FOR ENCLOSURE USING HOLE PATTERN ON THIS DRAWING.
- 1 JUNCTION BOX ENCLOSURE MUST BE MOUNTED WITH CONDUIT EXITING FROM BOTTOM.

NOTES:

WITH BUFFER BD

DIMENSIONAL TOLERANCES UNLESS OTHERWISE SPECIFIED FRACTIONS DECIMALS ANGLES 0 TO 4 ±1/32 .001 ±.01 ±30° 4 TO 8 ±1/16 .002 ±.005 RMS FINISH 8 AND UP ±1/8 ALL DIMENSIONS ARE IN INCHES DO NOT SCALE THIS DRAWING		USED ON DASH NO NEXT ASSEMBLY -01 1906-0000		TELEDYNE INSTRUMENTS Monitor Labs A Teledyne Technologies Company THIS DOCUMENT CONTAINS INFORMATION PROPRIETARY AND CONFIDENTIAL TO TELEPHONE MONITOR LABS AND IS FURNISHED UNDER THE EXPRESS CONDITION THAT INFORMATION CONTAINED HEREIN WILL NOT BE REPRODUCED, REPRICATED, DISCLOSED OR DISSEMINATED TO OTHERS OR USED FOR ANY PURPOSE OTHER THAN IN CONNECTION WITH THE EVALUATION THEREOF WITHOUT THE PRIOR WRITTEN CONSENT OF TELEPHONE MONITOR LABS.	
AUTHORIZATION BY DATE DRAWN EAS 9-27-01 CHECKED EAS Mar-02 DESIGNED EAS Feb-02 ENGINEERED ELM 3-27-02 PRODUCTION PD 3-27-02 Q.A. AS 3-27-02		MAT'L. FINISH		TITLE JUNCTION BOX MTG. METHODS AND CLEARANCES	
ALL DIMENSIONS IN () ARE METRIC.		SCALE SHEET NTS 1 OF 2		DRAWING NO. D 1906-0010	
PROJECTION		JIG NO.		LATEST REVISION A	

ALL DIMENSIONS IN () ARE METRIC.

REVISIONS				
ZONE	SYM.	DESCRIPTION	DATE	APPD.
	A	NO CHANGE THIS SHEET	1-8-03	DMB

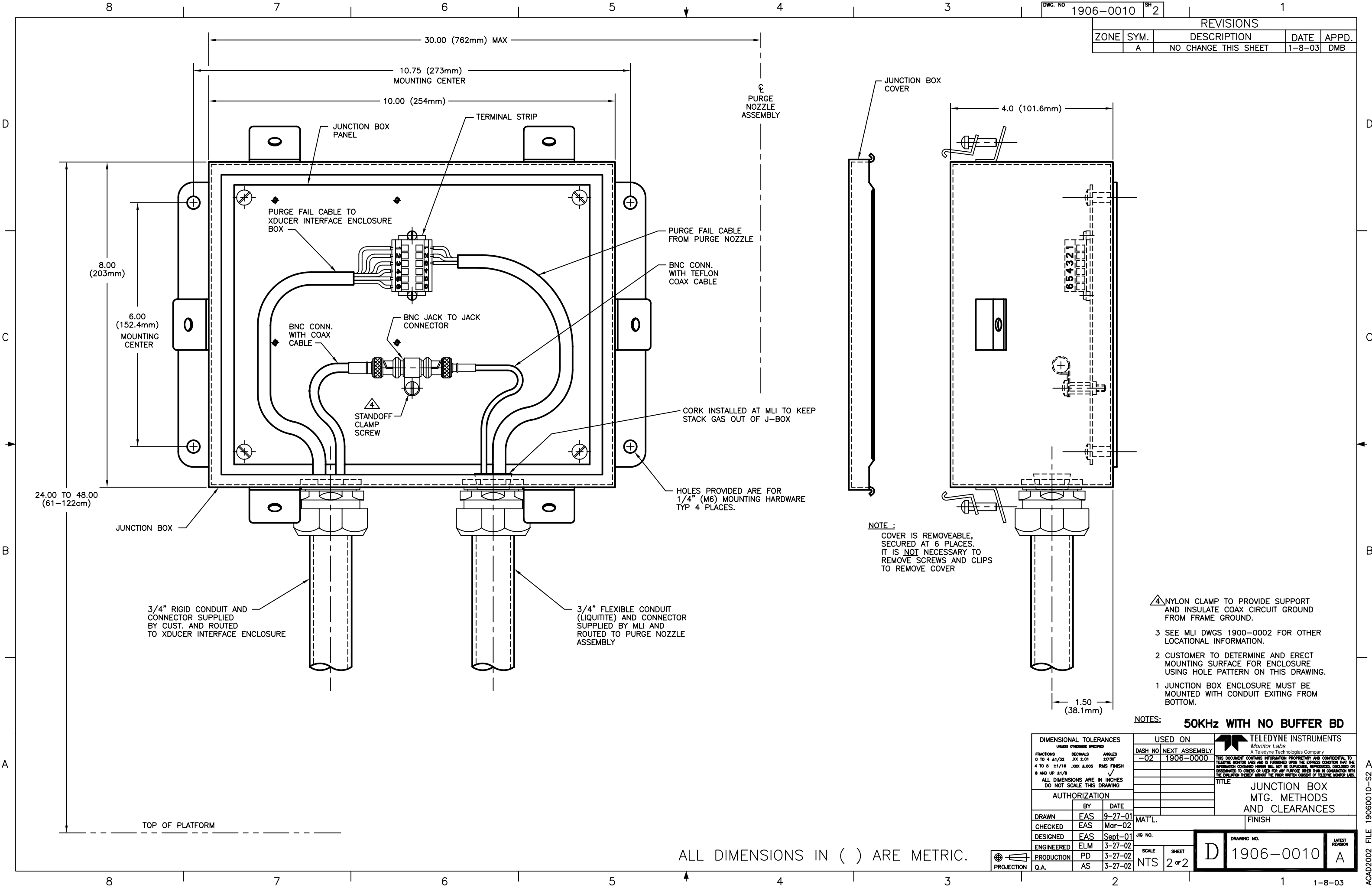

NOTE :
COVER IS REMOVEABLE,
SECURED AT 6 PLACES.
IT IS NOT NECESSARY TO
REMOVE SCREWS AND CLIPS
TO REMOVE COVER

- 4 NYLON CLAMP TO PROVIDE SUPPORT AND INSULATE COAX CIRCUIT GROUND FROM FRAME GROUND.
- 3 SEE MLI DWGS 1900-0002 FOR OTHER LOCALATIONAL INFORMATION.
- 2 CUSTOMER TO DETERMINE AND ERECT MOUNTING SURFACE FOR ENCLOSURE USING HOLE PATTERN ON THIS DRAWING.
- 1 JUNCTION BOX ENCLOSURE MUST BE MOUNTED WITH CONDUIT EXITING FROM BOTTOM.

NOTES: 50KHz WITH NO BUFFER BD

<p>DIMENSIONAL TOLERANCES UNLESS OTHERWISE SPECIFIED</p> <p>FRACTIONS DECIMALS ANGLES</p> <p>0 TO 4 ±1/32 .001 ±.01 ±30'</p> <p>4 TO 8 ±1/16 .002 ±.005 RMS FINISH</p> <p>8 AND UP ±1/8</p> <p>ALL DIMENSIONS ARE IN INCHES DO NOT SCALE THIS DRAWING</p>		<p>USED ON</p> <p>DASH NO NEXT ASSEMBLY</p> <p>-02 1906-0000</p>		<p>TELEDYNE INSTRUMENTS Monitor Labs A Teledyne Technologies Company</p> <p>THIS DOCUMENT CONTAINS INFORMATION PROPRIETARY AND CONFIDENTIAL TO TELEDYNE INSTRUMENTS AND IS FURNISHED UNDER THE EXPRESS CONDITION THAT THE INFORMATION CONTAINED HEREIN WILL NOT BE REPRODUCED, REPRICATED, DISCLOSED OR DISSEMINATED TO OTHERS OR USED FOR ANY PURPOSE OTHER THAN IN CONNECTION WITH THE EVALUATION HEREOF WITHOUT THE PRIOR WRITTEN CONSENT OF TELEDYNE INSTRUMENTS.</p>	
<p>AUTHORIZATION</p> <p>BY DATE</p> <p>DRAWN EAS 9-27-01</p> <p>CHECKED EAS Mar-02</p> <p>DESIGNED EAS Sept-01</p> <p>ENGINEERED ELM 3-27-02</p> <p>PRODUCTION PD 3-27-02</p> <p>Q.A. AS 3-27-02</p>		<p>MAT'L.</p> <p>FINISH</p>		<p>TITLE</p> <p>JUNCTION BOX MTG. METHODS AND CLEARANCES</p>	
<p>PROJECTION</p>		<p>SCALE SHEET</p> <p>NTS 2 OF 2</p>		<p>DRAWING NO.</p> <p>D 1906-0010</p>	
				<p>LATEST REVISION</p> <p>A</p>	

ALL DIMENSIONS IN () ARE METRIC.

REVISIONS				
ZONE	SYM.	DESCRIPTION	DATE	APPD.
	G	PER DCN 1803-2003G	9-6-11	ELM
	H	PER DCN 1803-2003H	4-25-12	FWD

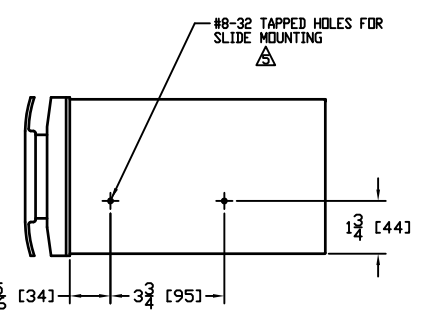
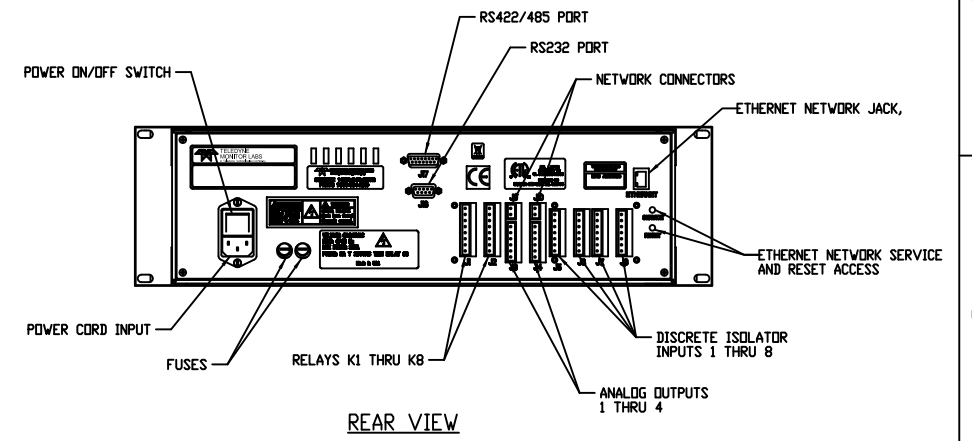
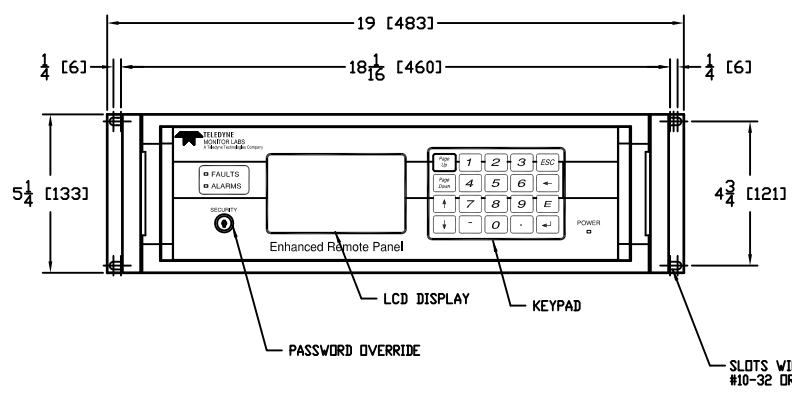
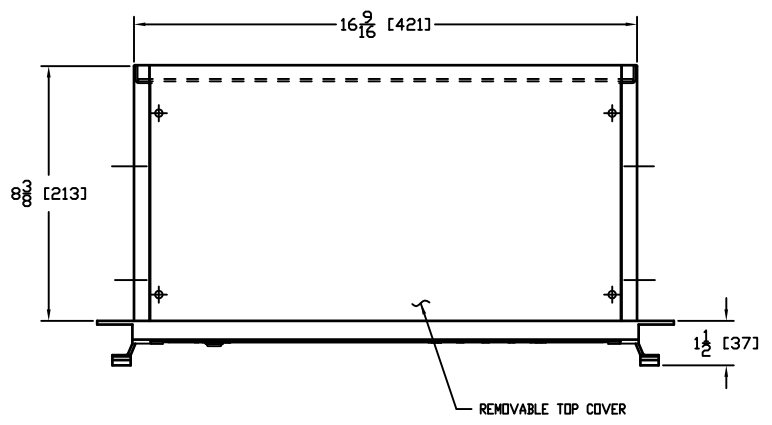

△ SLIDES ARE AVAILABLE AS AN OPTION. CONSULT FACTORY

4

3 MINIMUM REAR CLEARANCE 5"(127mm)

2 DIMENSIONS IN Ø ARE METRIC

1 DISPLAY FITS IN STANDARD 19"(482.6mm) RACK MOUNT, 5-1/4" (3U) HIGH CHASSIS

NOTE:

CUSTOMER OUTLINE DRAWING

TELEDYNE MONITOR LABS Everywhereyoulook		
DIMENSIONAL TOLERANCES <small>UNLESS OTHERWISE SPECIFIED</small> DECIMALS: 0 TO 4 DIGIT: .XX.XX .XXXX FRACTIONS: 1 TO 16: 1/16 1/8 3/16 1/4 3/8 1/2 5/8 3/4 7/8 ALL DIMENSIONS ARE IN INCHES UNLESS NOTED OTHERWISE DO NOT SCALE THESE DRAWINGS	USED ON BASH NEXT ASSEMBLY -02	<small>THESE DIMENSIONS CONFORM TO THE STANDARD OF THE INTERNATIONAL UNION OF PURE AND APPLIED PHYSICS AND CHEMISTRY (IUPAC) AND TO THE INTERNATIONAL UNION OF PURE AND APPLIED PHYSICS (IUPAP) AND TO THE INTERNATIONAL UNION OF PURE AND APPLIED CHEMISTRY (IUPAC). THESE DIMENSIONS CONFORM TO THE STANDARD OF THE INTERNATIONAL UNION OF PURE AND APPLIED PHYSICS AND CHEMISTRY (IUPAC) AND TO THE INTERNATIONAL UNION OF PURE AND APPLIED PHYSICS (IUPAP) AND TO THE INTERNATIONAL UNION OF PURE AND APPLIED CHEMISTRY (IUPAC).</small>
AUTHORIZATION BY DATE EAS 16-JUL-02 EAS 7-18-02 EAS JUL-02 ELM 7-24-02 PD 7-24-02 AS 7-24-02		
TITLE TML ENHANCED REMOTE PANEL ASSEMBLY, W/NEW CASE FINISH		
SCALE 1/2		SHEET 2 of 2
D	1803-2003	H

PROJECTION

REVISIONS			
SYM.	DESCRIPTION	DATE	APPD.
A	ADDED THIS SHEET PER DCN 1903-0012A	11-18-03	ELM
B	PER DCN 1903-0012B	12-12-07	ELM

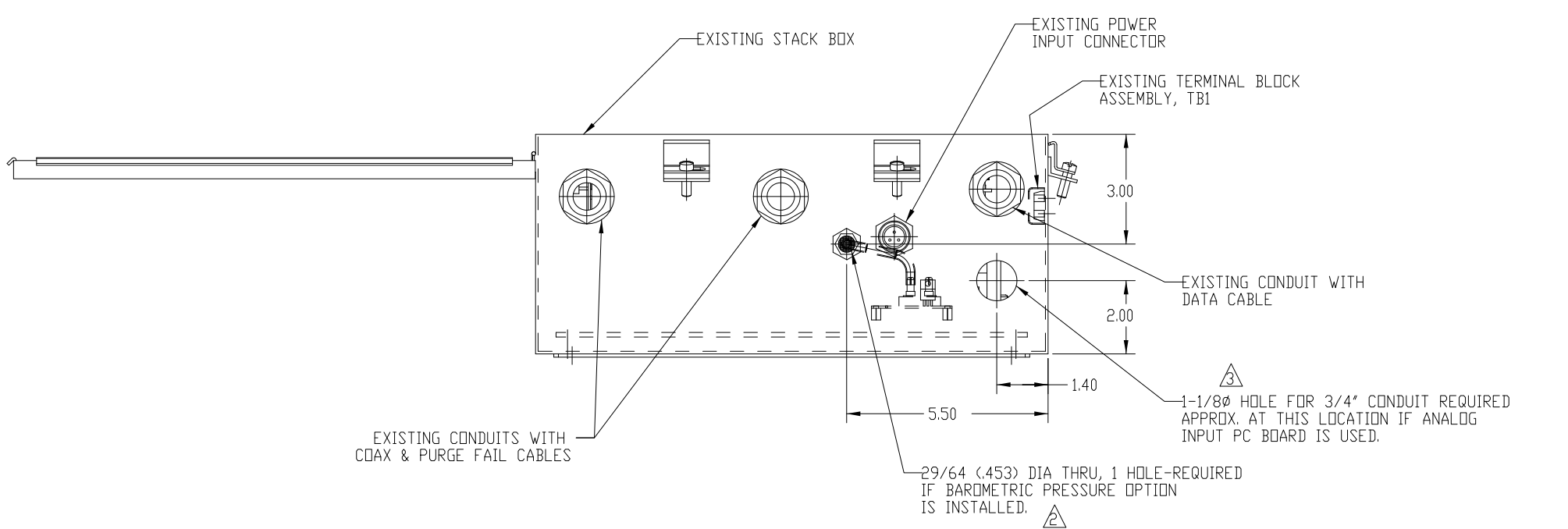
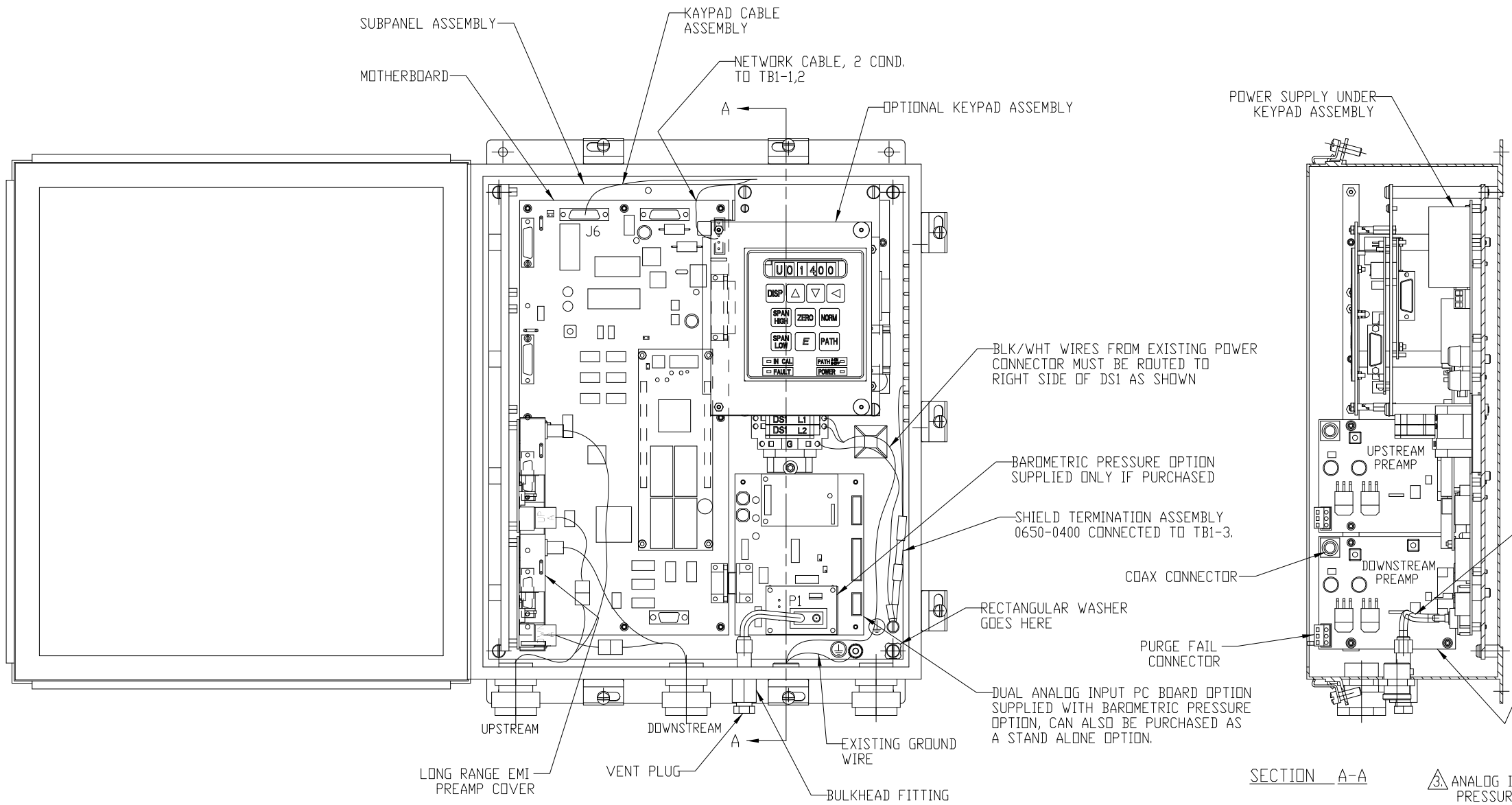

⚠ ANALOG INPUT BOARD: IF USED EXTERNAL TEMP. OR PRESSURE INPUT WIRES WILL NEED ROUTED TO PC BOARD THRU 3/4" CONDUIT AS NOTED.

⚠ BAROMETRIC PRESSURE OPTION: IF SUPPLIED DRILL NEW HOLE AS NOTED. INSTALL BULKHEAD FITTING & SECURE WITH SEAL NUT. INSTALL VENT PLUG INTO OUTSIDE OF FITTING. INSTALL INSERT INTO ONE END OF VITON TUBING & INSTALL THAT END INTO FITTING. TIGHTEN FITTING 1-1/4 TURNS. INSTALL OTHER END OF TUBING ONTO P1 ON PRESSURE TRANSDUCER.

1. GENERAL INSTRUCTIONS: REMOVE J1 FROM MICROPROCESSOR PC BOARD & DISCONNECT OTHER END FROM TB1. DISCONNECT ALL OTHER WIRES FROM BOTTOM SIDE OF TB1 & ALSO FROM PWR SUPPLY & PREAMPS. DATA CABLE CAN REMAIN ATTACHED TO TOP OF TB1. REMOVE OLD SUB-PANEL WITH PC BOARDS. DRILL HOLES FOR OPTIONS PER NOTES IF PURCHASED. INSTALL NEW SUB-PANEL ASSEMBLY. RECONNECT WIRES PER SYSTEM WIRING DIAGRAM 1900-0005, SHT-1 FOR STD RANGE, SHT-2 FOR LONG RANGE.

NOTES:

-02 PANEL MOUNTED KEYPAD

DIMENSIONAL TOLERANCES UNLESS OTHERWISE SPECIFIED		
FRACTIONS	DECIMALS	ANGLES
0 TO +1/32	±0.01	±30'
4 TO 8 ±1/16	±0.005	RMS FINISH
8 AND UP ±1/8		
ALL DIMENSIONS ARE IN INCHES DO NOT SCALE THIS DRAWING		

USED ON	
DASH NO.	NEXT ASSEMBLY
-02	UF150/PORD

TELEDYNE INSTRUMENTS	
Monitor Labs	
THIS DOCUMENT CONTAINS INFORMATION PROPRIETARY AND CONFIDENTIAL TO TELEDYNE MONITOR LABS AND IS FURNISHED UPON THE EXPRESS CONDITION THAT THE INFORMATION CONTAINED HEREIN WILL NOT BE REPRODUCED, REPIRATED, DISCLOSED OR DISSEMINATED TO OTHERS OR USED FOR ANY PURPOSE OTHER THAN IN CONNECTION WITH THE EVALUATION THEREOF WITHOUT THE PRIOR WRITTEN CONSENT OF TELEDYNE MONITOR LABS.	
TITLE	
UF150 SUB PANEL ASSY, UPGRADE INSTALLATION	
AUTHORIZATION	
DRAWN	EAS 18-Nov-03
CHECKED	EAS 12-3-03
DESIGNED	EAS Nov-03
ENGINEERED	ELM 12-4-03
PRODUCTION	PD 12-4-03
D.N.	AS 12-4-03



SCALE	SHEET
0.500	2 OF 2

DRAWING NO.	REVISION
1903-0012	B

REVISIONS				
ZONE	SYM.	DESCRIPTION	DATE	APPD.
A		NO CHANGE THIS SHEET	4-22-03	ELM
B		PER DCN 1900-0005B	12-1-03	DMB
C		PER DCN 1900-0005C	12-12-07	ELM

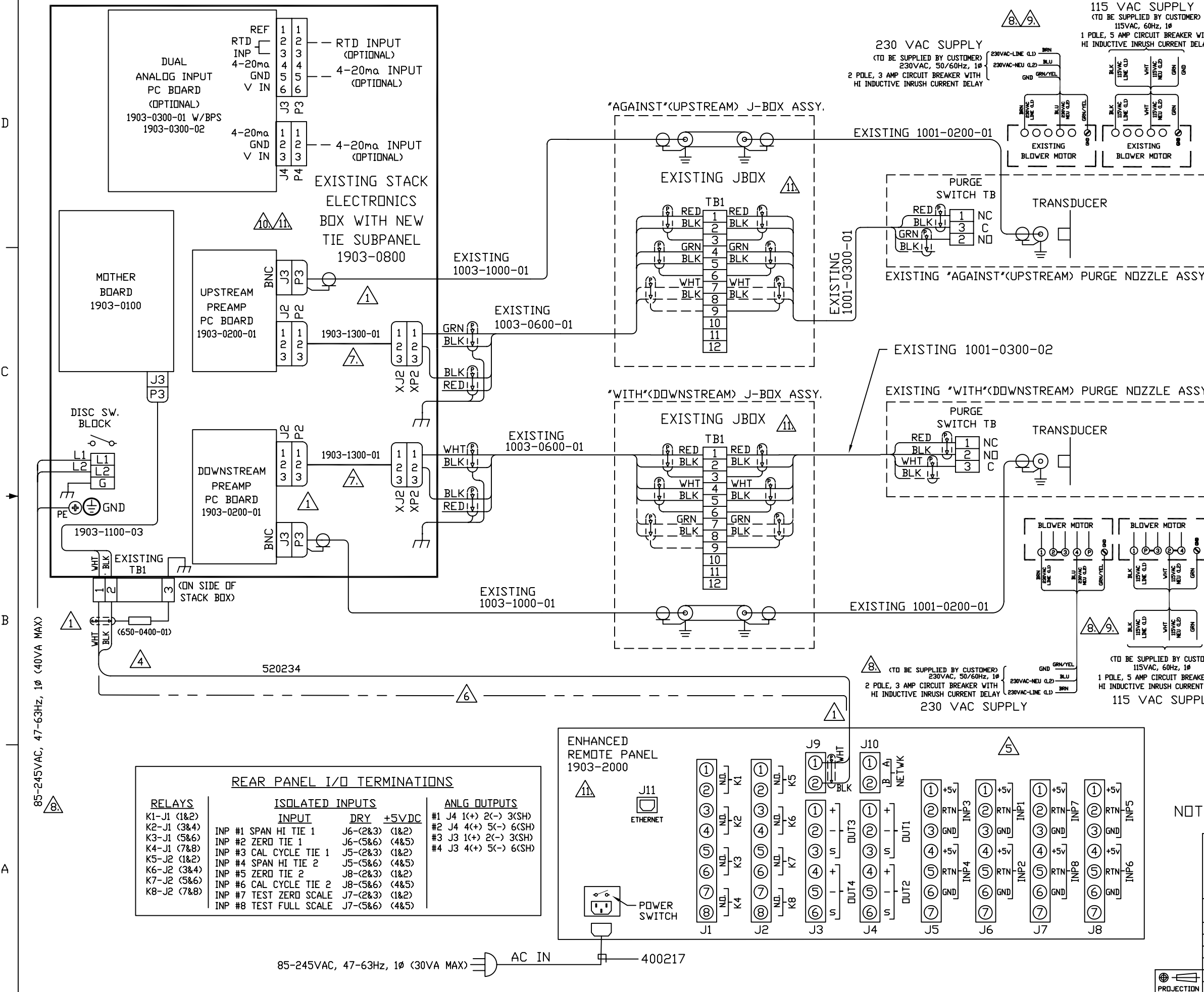

- 1. MAINTENANCE PROCEDURES REQUIRING THE REMOVAL OF THE COVER ARE INTENDED TO BE PERFORMED BY TRAINED PERSONNEL ONLY. CONSULT MANUAL.
- 2. ALL FIELD WIRING TERMINATED ON STACK MOUNTED EQUIPMENT TO BE RATED MINIMUM 75 DEGREES C.
- 3. IF LINK ROD OPTION IS PROVIDED, DUAL BLOWERS OF THE HIGHER CFM RATING (SBI) MAY BE REQUIRED, AND PROTECTIVE DISCONNECT DEVICES SHOULD BE CHOSEN ACCORDINGLY. CONTACT TML FOR ALL CIRCUIT BREAKER RECOMMENDATIONS.
- 4. CUSTOMER TO PROVIDE CIRCUIT BREAKERS OF APPROPRIATE RATING AT SAME ELEVATION AS TML EQUIPMENT BEING SUPPLIED. LABEL DISC. DEVICES WITH NAME/TAG NO. OF EACH DEVICE BEING SUPPLIED. CONTACT TML FOR RECOMMENDED BREAKERS.
- 5. 1903-1300 EXTENSION CABLE TO BE USED ONLY WHEN EXISTING PURGE CABLE FROM MODEL 100 IS NOT LONG ENOUGH TO REACH THE PREAMP CONNECTOR P2. STRIP WIRES .3" AND INSERT INTO CAGE CLAMP STYLE CONNECTOR P2 OR XP2 AS REQUIRED. P2 SUPPLIED WITH PC BOARD; XP2 SUPPLIED WITH 1903-1300 EXTENSION CABLE.
- 6. IF FIBRELINK III OPTION IS PROVIDED, CONNECT CONTROL UNITS AND DATA CABLES PER TML SUPPLEMENTAL WIRING DIAGRAM 1808-0003, SHT. 4 AND 1808-0007.
- 7. SEE 'REAR PANEL I/O TABLE' FOR WIRE TERMINATIONS.
- 8. RECOMMENDED STACK NETWORK CABLE IS "SHIELDED". SHIELDS MUST BE TERMINATED AS SHOWN AND WITH 0650-0400-01 TERMINATOR AT THE TIE BOX. IN NO INSTALLATION SHALL DATA CABLE BE RUN IN TRAYS OR CONDUIT WITH OTHER CABLES EXCEEDING 230 VAC.
- 9. IT IS ASSUMED THAT EXISTING DUAL BLOWERS ARE RETAINED FOR UPGRADE. BOTH 115VAC AND 230VAC SUPPLIES SHOWN.
- 10. ALL CUSTOMER CONNECTIONS TO ANALOG OUTPUTS MUST BE THRU TWISTED PAIR SHIELDED CABLES. ALL SUCH SHIELDS SHALL TERMINATE AT J4-3; J4-6; J3-3; J3-6 FOR OUTPUTS 1 THRU 4 RESPECTIVELY.

NOTES: 1. TERMINATED AT SITE DURING FINAL INSTALLATION.

REAR PANEL I/O TERMINATIONS																																									
RELAYS	ISOLATED INPUTS	ANLG OUTPUTS																																							
K1-J1 (1&2) K2-J1 (3&4) K3-J1 (5&6) K4-J1 (7&8) K5-J2 (1&2) K6-J2 (3&4) K7-J2 (5&6) K8-J2 (7&8)	<table border="1"> <thead> <tr> <th>INPUT</th> <th>DRY</th> <th>+5VDC</th> </tr> </thead> <tbody> <tr> <td>INP #1 SPAN HI TIE 1</td> <td>J6-(2&3)</td> <td>(1&2)</td> </tr> <tr> <td>INP #2 ZERO TIE 1</td> <td>J6-(5&6)</td> <td>(4&5)</td> </tr> <tr> <td>INP #3 CAL CYCLE TIE 1</td> <td>J5-(2&3)</td> <td>(1&2)</td> </tr> <tr> <td>INP #4 SPAN HI TIE 2</td> <td>J5-(5&6)</td> <td>(4&5)</td> </tr> <tr> <td>INP #5 ZERO TIE 2</td> <td>J8-(2&3)</td> <td>(1&2)</td> </tr> <tr> <td>INP #6 CAL CYCLE TIE 2</td> <td>J8-(5&6)</td> <td>(4&5)</td> </tr> <tr> <td>INP #7 TEST ZERO SCALE</td> <td>J7-(2&3)</td> <td>(1&2)</td> </tr> <tr> <td>INP #8 TEST FULL SCALE</td> <td>J7-(5&6)</td> <td>(4&5)</td> </tr> </tbody> </table>	INPUT	DRY	+5VDC	INP #1 SPAN HI TIE 1	J6-(2&3)	(1&2)	INP #2 ZERO TIE 1	J6-(5&6)	(4&5)	INP #3 CAL CYCLE TIE 1	J5-(2&3)	(1&2)	INP #4 SPAN HI TIE 2	J5-(5&6)	(4&5)	INP #5 ZERO TIE 2	J8-(2&3)	(1&2)	INP #6 CAL CYCLE TIE 2	J8-(5&6)	(4&5)	INP #7 TEST ZERO SCALE	J7-(2&3)	(1&2)	INP #8 TEST FULL SCALE	J7-(5&6)	(4&5)	<table border="1"> <tbody> <tr> <td>#1 J4 1(+)</td> <td>2(-)</td> <td>3(SH)</td> </tr> <tr> <td>#2 J4 4(+)</td> <td>5(-)</td> <td>6(SH)</td> </tr> <tr> <td>#3 J3 1(+)</td> <td>2(-)</td> <td>3(SH)</td> </tr> <tr> <td>#4 J3 4(+)</td> <td>5(-)</td> <td>6(SH)</td> </tr> </tbody> </table>	#1 J4 1(+)	2(-)	3(SH)	#2 J4 4(+)	5(-)	6(SH)	#3 J3 1(+)	2(-)	3(SH)	#4 J3 4(+)	5(-)	6(SH)
INPUT	DRY	+5VDC																																							
INP #1 SPAN HI TIE 1	J6-(2&3)	(1&2)																																							
INP #2 ZERO TIE 1	J6-(5&6)	(4&5)																																							
INP #3 CAL CYCLE TIE 1	J5-(2&3)	(1&2)																																							
INP #4 SPAN HI TIE 2	J5-(5&6)	(4&5)																																							
INP #5 ZERO TIE 2	J8-(2&3)	(1&2)																																							
INP #6 CAL CYCLE TIE 2	J8-(5&6)	(4&5)																																							
INP #7 TEST ZERO SCALE	J7-(2&3)	(1&2)																																							
INP #8 TEST FULL SCALE	J7-(5&6)	(4&5)																																							
#1 J4 1(+)	2(-)	3(SH)																																							
#2 J4 4(+)	5(-)	6(SH)																																							
#3 J3 1(+)	2(-)	3(SH)																																							
#4 J3 4(+)	5(-)	6(SH)																																							

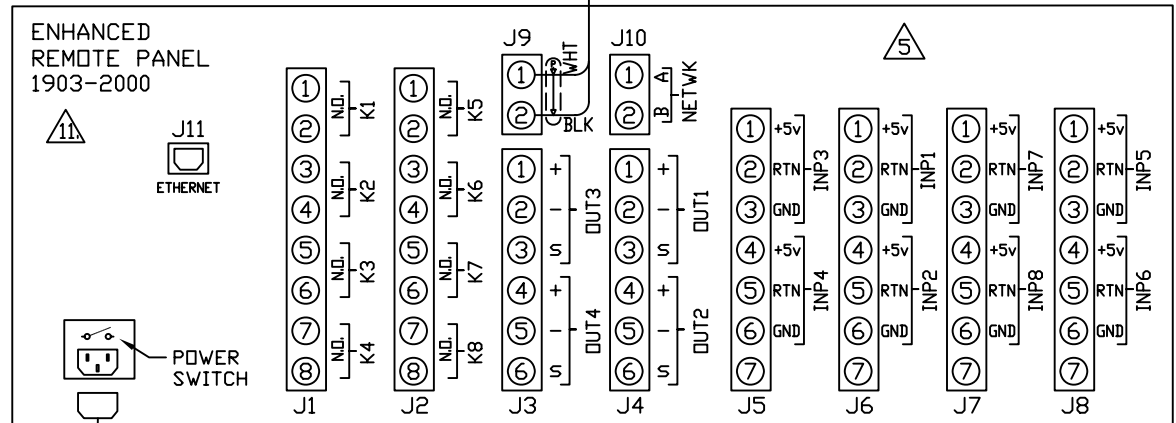

DIMENSIONAL TOLERANCES		USED ON		TELEDYNE INSTRUMENTS	
UNLESS OTHERWISE SPECIFIED		DASH NO	NEXT ASSEMBLY	Monitor Labs	
FRACTIONS	DECIMALS	1900-0000		A Teledyne Technologies Company	
0 TO 4 41/32	.001			THIS DOCUMENT CONTAINS PROPRIETARY AND CONFIDENTIAL INFORMATION. IT IS THE PROPERTY OF TELEDYNE INSTRUMENTS AND IS FURNISHED UNDER THE EXPRESS CONDITION THAT THE INFORMATION CONTAINED HEREIN WILL NOT BE REPRODUCED, REPRICED, OR DISSEMINATED TO OTHERS OR USED FOR ANY PURPOSE OTHER THAN THAT AUTHORIZED BY THE EVALUATION RECEIPT WITHOUT THE EXPRESS WRITTEN CONSENT OF TELEDYNE INSTRUMENTS.	
5 TO 8 41/32	.002			TITLE UPGRADE	
9 AND UP 41/32	.005			ES WIRING W/EXISTING STACK ELECT. BOX/NEW TIE SUBPANEL	
ALL DIMENSIONS ARE IN INCHES UNLESS OTHERWISE SPECIFIED		AUTHORIZATION		FINISH	
DO NOT SCALE THIS DRAWING		BY	DATE	DRAWING NO.	
		DCH	5-23-02	1900-0005	
		CHECKED	7/18/02	LATEST REVISION	
		DESIGNED	5-23-02	C	
		ENGINEERED	7/18/02		
		PRODUCTION	7/19/02		
		Q.A.	7/18/02		

REVISIONS				
ZONE	SYM.	DESCRIPTION	DATE	APPD.
	A	NO CHANGE THIS SHEET	4-22-03	ELM
	B	PER DCN 1900-0005B	12-1-03	DMB
	C	PER DCN 1900-0005C	12-12-07	ELM

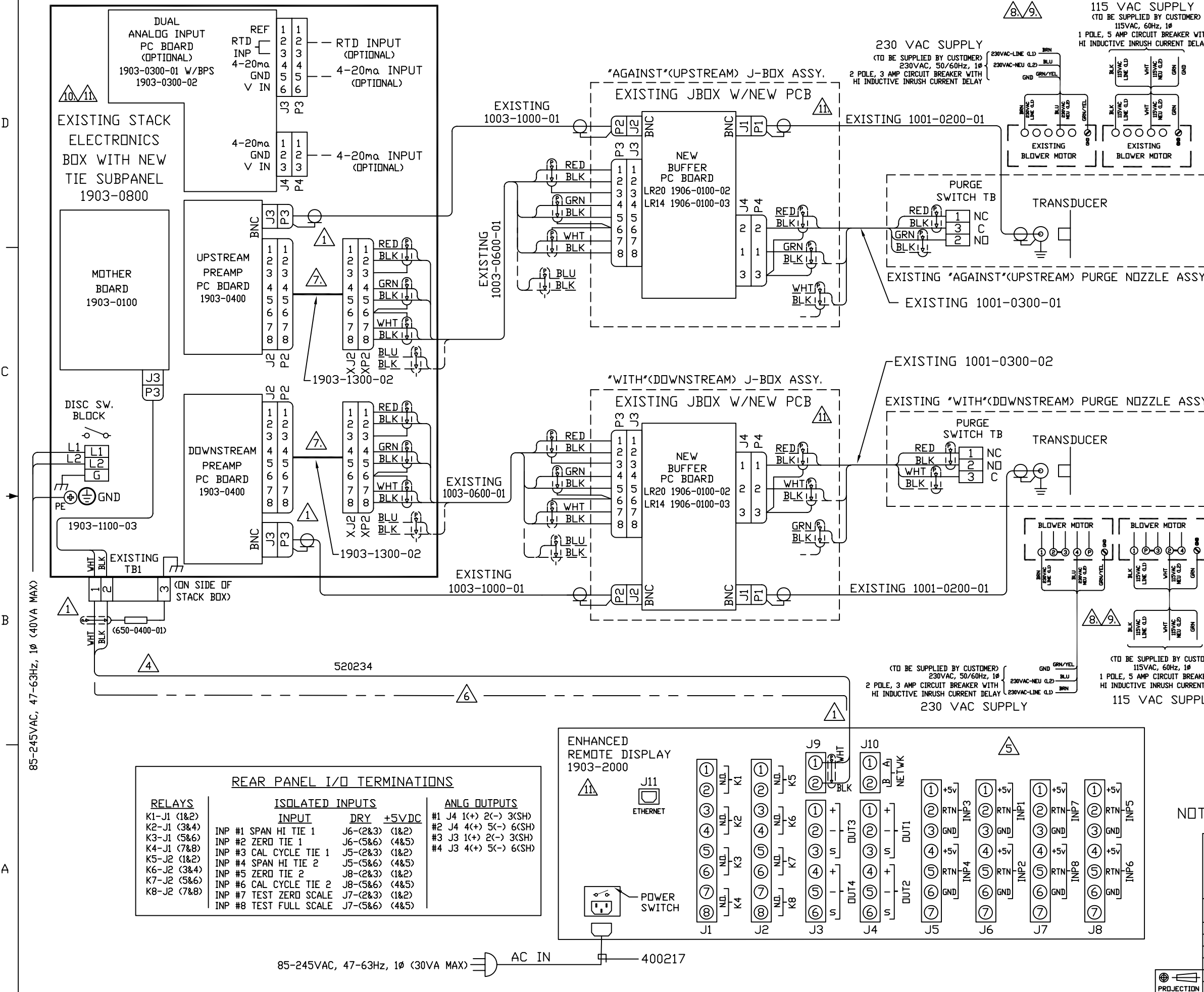

- ⚠ MAINTENANCE PROCEDURES REQUIRING THE REMOVAL OF THE COVER ARE INTENDED TO BE PERFORMED BY TRAINED PERSONNEL ONLY. CONSULT MANUAL.
- ⚠ ALL FIELD WIRING TERMINATED ON STACK MOUNTED EQUIPMENT TO BE RATED MINIMUM 75 DEGREES C.
- ⚠ IF LINK ROD OPTION IS PROVIDED, DUAL BLOWERS OF THE HIGHER CFM RATING (SB1) MAY BE REQUIRED, AND PROTECTIVE DISCONNECT DEVICES SHOULD BE CHOSEN ACCORDINGLY. CONTACT TML FOR ALL CIRCUIT BREAKER RECOMMENDATIONS.
- ⚠ CUSTOMER TO PROVIDE CIRCUIT BREAKERS OF OF APPROPRIATE RATING AT SAME ELEVATION AS TML EQUIPMENT BEING SUPPLIED. LABEL DISC. DEVICES WITH NAME/TAG NO. OF EACH DEVICE BEING SUPPLIED. CONTACT TML FOR RECOMMENDED BREAKERS.
- ⚠ 1903-1300 EXTENSION CABLE TO BE USED ONLY WHEN EXISTING PURGE CABLE FROM MODEL 100 IS NOT LONG ENOUGH TO REACH THE PREAMP CONNECTOR P2. STRIP WIRES .3" AND INSERT INTO CAGE CLAMP STYLE CONNECTOR P2 OR XP2 AS REQUIRED. P2 SUPPLIED WITH PC BOARD; XP2 SUPPLIED WITH 1903-1300 EXTENSION CABLE.
- ⚠ IF FIBRELINK III OPTION IS PROVIDED, CONNECT CONTROL UNITS AND DATA CABLES PER TML SUPPLEMENTAL WIRING DIAGRAM 1808-0003, SHT. 4 AND 1808-0007.
- ⚠ SEE 'REAR PANEL I/O TABLE' FOR WIRE TERMINATIONS.
- ⚠ RECOMMENDED STACK NETWORK CABLE IS "SHIELDED". SHIELDS MUST BE TERMINATED AS SHOWN AND WITH 0650-0400-01 TERMINATOR AT THE TIE BOX. IN NO INSTALLATION SHALL DATA CABLE BE RUN IN TRAYS OR CONDUIT WITH OTHER CABLES EXCEEDING 230 VAC.
- 3. IT IS ASSUMED THAT EXISTING DUAL BLOWERS ARE RETAINED FOR UPGRADE. BOTH 115VAC AND 230VAC SUPPLIES SHOWN.
- ⚠ ALL CUSTOMER CONNECTIONS TO ANALOG OUTPUTS MUST BE THRU TWISTED PAIR SHIELDED CABLES. ALL SUCH SHIELDS SHALL TERMINATE AT J4-3; J4-6; J3-3; J3-6 FOR OUTPUTS 1 THRU 4 RESPECTIVELY.

REAR PANEL I/O TERMINATIONS																																									
RELAYS	ISOLATED INPUTS	ANLG OUTPUTS																																							
K1-J1 (1&2) K2-J1 (3&4) K3-J1 (5&6) K4-J1 (7&8) K5-J2 (1&2) K6-J2 (3&4) K7-J2 (5&6) K8-J2 (7&8)	<table border="1"> <thead> <tr> <th>INPUT</th> <th>DRY</th> <th>+5VDC</th> </tr> </thead> <tbody> <tr> <td>INP #1 SPAN HI TIE 1</td> <td>J6-(2&3)</td> <td>(1&2)</td> </tr> <tr> <td>INP #2 ZERO TIE 1</td> <td>J6-(5&6)</td> <td>(4&5)</td> </tr> <tr> <td>INP #3 CAL CYCLE TIE 1</td> <td>J5-(2&3)</td> <td>(1&2)</td> </tr> <tr> <td>INP #4 SPAN HI TIE 2</td> <td>J5-(5&6)</td> <td>(4&5)</td> </tr> <tr> <td>INP #5 ZERO TIE 2</td> <td>J8-(2&3)</td> <td>(1&2)</td> </tr> <tr> <td>INP #6 CAL CYCLE TIE 2</td> <td>J8-(5&6)</td> <td>(4&5)</td> </tr> <tr> <td>INP #7 TEST ZERO SCALE</td> <td>J7-(2&3)</td> <td>(1&2)</td> </tr> <tr> <td>INP #8 TEST FULL SCALE</td> <td>J7-(5&6)</td> <td>(4&5)</td> </tr> </tbody> </table>	INPUT	DRY	+5VDC	INP #1 SPAN HI TIE 1	J6-(2&3)	(1&2)	INP #2 ZERO TIE 1	J6-(5&6)	(4&5)	INP #3 CAL CYCLE TIE 1	J5-(2&3)	(1&2)	INP #4 SPAN HI TIE 2	J5-(5&6)	(4&5)	INP #5 ZERO TIE 2	J8-(2&3)	(1&2)	INP #6 CAL CYCLE TIE 2	J8-(5&6)	(4&5)	INP #7 TEST ZERO SCALE	J7-(2&3)	(1&2)	INP #8 TEST FULL SCALE	J7-(5&6)	(4&5)	<table border="1"> <tbody> <tr> <td>#1 J4 1(+)</td> <td>2(-)</td> <td>3(SH)</td> </tr> <tr> <td>#2 J4 4(+)</td> <td>5(-)</td> <td>6(SH)</td> </tr> <tr> <td>#3 J3 1(+)</td> <td>2(-)</td> <td>3(SH)</td> </tr> <tr> <td>#4 J3 4(+)</td> <td>5(-)</td> <td>6(SH)</td> </tr> </tbody> </table>	#1 J4 1(+)	2(-)	3(SH)	#2 J4 4(+)	5(-)	6(SH)	#3 J3 1(+)	2(-)	3(SH)	#4 J3 4(+)	5(-)	6(SH)
INPUT	DRY	+5VDC																																							
INP #1 SPAN HI TIE 1	J6-(2&3)	(1&2)																																							
INP #2 ZERO TIE 1	J6-(5&6)	(4&5)																																							
INP #3 CAL CYCLE TIE 1	J5-(2&3)	(1&2)																																							
INP #4 SPAN HI TIE 2	J5-(5&6)	(4&5)																																							
INP #5 ZERO TIE 2	J8-(2&3)	(1&2)																																							
INP #6 CAL CYCLE TIE 2	J8-(5&6)	(4&5)																																							
INP #7 TEST ZERO SCALE	J7-(2&3)	(1&2)																																							
INP #8 TEST FULL SCALE	J7-(5&6)	(4&5)																																							
#1 J4 1(+)	2(-)	3(SH)																																							
#2 J4 4(+)	5(-)	6(SH)																																							
#3 J3 1(+)	2(-)	3(SH)																																							
#4 J3 4(+)	5(-)	6(SH)																																							

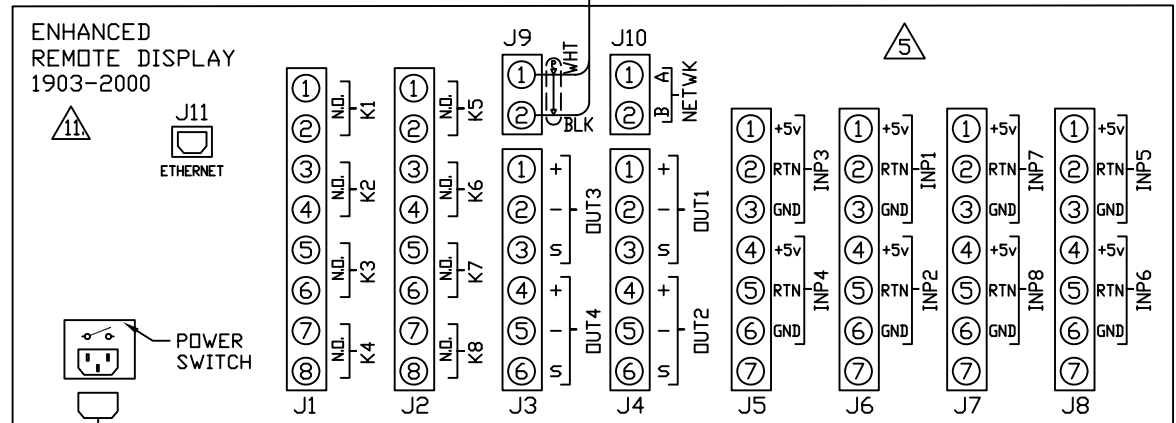

NOTES: ⚠ TERMINATED AT SITE DURING FINAL INSTALLATION.

DIMENSIONAL TOLERANCES UNLESS OTHERWISE SPECIFIED		USED ON	
FRACTIONS	DECIMALS	DASH NO	NEXT ASSEMBLY
0 TO 4 41/32	.XX	1900-0000	
4 TO 8 1/16	.XXX		
8 AND UP 1/8	.XXX		

TELEDYNE INSTRUMENTS
Monitor Labs
A Teledyne Technologies Company

THIS DOCUMENT CONTAINS INFORMATION PROPRIETARY AND CONFIDENTIAL TO TELEDYNE MONITOR LABS AND IS FURNISHED UNDER THE EXPRESS CONDITION THAT THE INFORMATION CONTAINED HEREIN WILL NOT BE REPRODUCED, REPERATED, DISCLOSED OR OTHERWISE USED IN ANY MANNER OTHER THAN AS AUTHORIZED BY THE EVALUATION RECEIPT WITHOUT THE PRIOR WRITTEN CONSENT OF TELEDYNE MONITOR LABS.

TITLE: UPGRADE
ULTRAFLOW 100 TO 150 LR WIRING W/NEW TIE SUBPANEL AND BUFFER BDS IN EXISTING JBOXES

AUTHORIZATION	
BY	DATE
DCH	5-24-02
ELM	7/18/02
DCH	5-23-02
ELM	7/18/02
PD	7/19/02
AS	7/18/02

SCALE: --- SHEET: 2 OF 4

DRAWING NO: 1900-0005 LATEST REVISION: C

85-245VAC, 47-63Hz, 1Ø (40VA MAX)

85-245VAC, 47-63Hz, 1Ø (30VA MAX) AC IN 400217

ACAD2002 FILE 19000005-S2

APPENDIX E
ENHANCED SERIAL PORT COMMUNICATION PROTOCOL

(This page intentionally left blank.)

ENHANCED SERIAL PORT COMMUNICATION PROTOCOL

This enhanced serial port protocol is only available with Enhanced Remote Panel 332 version 1.10 or later.

A short description of the original communication is described in the Enhanced Remote Display section of the manual. It explains how to use the simple commands which use a question mark (?) or a dollar sign (\$) to request information from the RS232 or RS422/485 ports of the Enhanced Remote Panel. This is still a valid form of communication with either of these ports. The configuration of the serial ports are still fixed at 9600, 8 bits, no parity, two stop bits.

Although the original type of communication is very simple, it has some drawbacks. One of these shortcomings is the fact that there is no data validation within the structure of the protocol and as a result, characters could be lost from time to time.

As more customers requested the ability to acquire data serially from our instruments for their Data Acquisition and Handling Systems, we went back to the format used on some of the older equipment designed by our engineers. It consists of four values separated by commas ending in a 'Carriage-Return' and 'Line-Feed'. The first and third values must match exactly. The second and fourth values must also match exactly. If **either** of these two conditions are not met, then the Enhanced Remote Panel will ignore the data stream as an input. In a similar manner, a DAS should ignore any data streams which do not have matching pairs.

A typical command or data stream would look like the following:

“first value”, “second value”, “first value repeated”, “second value repeated”<CR> <LF>

There are two types of functions which can be sent to the Enhanced Remote Panel using this format. One function is a more robust and error free way in which to request data. The other function is the ability to command and control calibrations and initiate other modes of operation. It is important to note that program parameters **CANNOT** be modified from the serial ports.

MATCHED PAIR DATA REQUEST PROTOCOL FOR A DAS

To request data in the matched pair format, use the following command line:

990 “variable number”, 990, “variable number”<CR> <LF>

The “variable number” is the same number designation used to number the variables in the original protocol. A list of the variable numbers can be obtained from the Enhanced Remote Panel by using the original 255? command. An example is included later in this appendix.

STATUS HISTORY PRINT OUT

The information contained in the Status History screens can be acquired through serial port using the following commands:

991?<CR> will print out the Status History for TIE 1

992?<CR> will print out the Status History for TIE 2

There are six possible sets of Status History screens for each TIE. Two sets of Status History screens are possible for each Path; one for the Primary Status, another for the Extended Status. There is also a set of history screens for the combined Path A + B/2 configuration. The list is displayed in chronological order with the most recent entry at the top of the list. The date and time that the status code happened is included on the same line. A value of zero "0" means that all faults were cleared. If there are no entries in a specific set of status history screens then nothing will be listed under its heading.

The following is an example what the print out looks like:

```
991?
TIE1 PATHA PRIMARY STATUS
TIE1 PATHA EXTENDED STATUS
  0 1-Mar-2006 8:22:35
 10 1-Mar-2006 8:22:01
TIE1 PATHB PRIMARY STATUS
TIE1 PATHB EXTENDED STATUS
  0 1-Mar-2006 8:22:35
 10 1-Mar-2006 8:22:17
TIE1 PATHAB PRIMARY STATUS
TIE1 PATHAB EXTENDED STATUS
  0 1-Mar-2006 8:22:35
 10 1-Mar-2006 8:22:17
```

```
992?
TIE2 PATHA PRIMARY STATUS
 3000 1-Mar-2006 8:28:18
 3000 1-Mar-2006 8:26:57
TIE2 PATHA EXTENDED STATUS
TIE2 PATHB PRIMARY STATUS
TIE2 PATHB EXTENDED STATUS
TIE2 PATHAB PRIMARY STATUS
TIE2 PATHAB EXTENDED STATUS
```

ALARM HISTORY PRINT OUT

The commands 993?<CR> and 994?<CR> prints out information from the Alarm History screens. An enumeration is used to define the alarms. The first value is for the Alarm Description and can be decoded from the table below. The second number tells you if the alarm was SET or CLEARED. A value of one "1" is for SET and a value of zero "0" is for CLEAR.

Enumeration	Alarm Description
00	TIE1 Instantaneous Flow Actual Alarm for Path A
01	TIE1 Average Flow Actual Alarm for Path A
02	TIE1 Instantaneous Standardized Flow Alarm for Path A
03	TIE1 Average Standardized Flow Alarm for Path A
04	TIE1 Instantaneous Flow Actual Alarm for Path B
05	TIE1 Average Flow Actual Alarm for Path B
06	TIE1 Instantaneous Standardized Flow Alarm for Path B
07	TIE1 Average Standardized Flow Alarm for Path B
08	TIE1 Instantaneous Flow Actual Alarm for Paths A&B combined
09	TIE1 Average Flow Actual Alarm for Paths A&B combined
10	TIE1 Instantaneous Standardized Flow Alarm for Paths A&B combined
11	TIE1 Average Standardized Flow Alarm for Paths A&B combined
12	TIE2 Instantaneous Flow Actual Alarm for Path A
13	TIE2 Average Flow Actual Alarm for Path A
14	TIE2 Instantaneous Standardized Flow Alarm for Path A
15	TIE2 Average Standardized Flow Alarm for Path A
16	TIE2 Instantaneous Flow Actual Alarm for Path B
17	TIE2 Average Flow Actual Alarm for Path B
18	TIE2 Instantaneous Standardized Flow Alarm for Path B
19	TIE2 Average Standardized Flow Alarm for Path B
20	TIE2 Instantaneous Flow Actual Alarm for Paths A&B combined
21	TIE2 Average Flow Actual Alarm for Paths A&B combined
22	TIE2 Instantaneous Standardized Flow Alarm for Paths A&B combined
23	TIE2 Average Standardized Flow Alarm for Paths A&B combined
24	TIE1 Instantaneous Temperature Alarm for Path A
25	TIE1 Average Temperature Alarm for Path A
26	TIE1 Instantaneous Temperature Alarm for Path B
27	TIE1 Average Temperature Alarm for Path B
28	TIE1 Instantaneous Temperature Alarm for Paths A&B combined
29	TIE1 Average Temperature Alarm for Paths A&B combined
30	TIE1 Instantaneous External Temperature Alarm
31	TIE1 Average External Temperature Alarm
32	TIE2 Instantaneous Temperature Alarm for Path A
33	TIE2 Average Temperature Alarm for Path A
34	TIE2 Instantaneous Temperature Alarm for Path B
35	TIE2 Average Temperature Alarm for Path B
36	TIE2 Instantaneous Temperature Alarm for Paths A&B combined
37	TIE2 Average Temperature Alarm for Paths A&B combined
38	TIE2 Instantaneous External Temperature Alarm
39	TIE2 Average External Temperature Alarm

INITIATION AND CONTROL OF CALIBRATIONS AND MODES OF OPERATION

The system calibration may be initiated and controlled from the serial port. TIE1 and TIE2 may be controlled independently when both are present. The following command string may be used.

The command string for TIE1 is as follows: 998, "command", 998, "command" <CR> <LF>

The command string for TIE2 is as follows: 999, "command", 999, "command" <CR> <LF>

The value for "command" is chosen from the following list of commands.

Command Number	Action resulting from specified Command Number
1	NORMAL
2	SPANHIGH
3	SPANLOW
4	ZERO
5	DIAGNOSTIC (this command should not be used)
6	TEST_FULL_SCALE (for MIO 4 to 20 mA outputs)
7	TEST_MID_SCALE (for MIO 4 to 20 mA outputs)
8	TEST_ZERO_SCALE (for MIO 4 to 20 mA outputs)
9	CAL_CYCLE (the TIE will complete a full calibration cycle typically consisting of both Zero and Span High modes and then returning to Normal operation.
10	PUT_OUT_OF_SERVICE (may be used to indicate when maintenance is done on the monitor)
11	PUT_IN_SERVICE (may be used to indicate when the monitor is finished having maintenance done on it)
12	RESET (sends a command to reset the TIE)
13	RECONFIG (sends a command to reconfigure the FPGA)

- MIO stands for the printed circuit board (Multi Input Output) commonly used to interface with computers via isolator inputs, relay outputs and analog outputs)
- TIE stands for the Transducer Interface Enclosure where the electronics which makes the measurement is located.
- FPGA stands for Field Programmable Gate Array which is an I.C. within the TIE.

For example to request the TIE1 to go into the SPANHIGH mode the following command line would be used.

998, 2, 998, 2 <CR> <LF>

If the following command line is given to the ENHANCED REMOTE PANEL, it will list the commands available for the calibration input command line as shown in the above table.

997 ? <CR> <LF>

A SUMMARY OF THE ENHANCED COMMANDS AVIALABLE

The program variables are listed later in this appendix.

The 990, 998 and 999 commands described below are used with the matched-pair format.

- 990 This variable is used to request variables in the matched-pair format. The following is the proper way to use this variable:
 990, "VAR#",990,"VAR#"`<CR>` where "VAR#" is the variable number desired.
 After receiving this input the ERP will respond with the following output:
 "VAR#","VALUE of VAR#","VAR#","VALUE of VAR#"`<CR>`
- 991 This variable is used to request the STATUS HISTORY of TIE1
 Proper usage is: 991?`<CR>`
 The ERP will respond by printing the STATUS HISTORY in a similar format as on the ERP screen display.
- 992 This variable is used to request the STATUS HISTORY of TIE2
 Proper usage is: 992?`<CR>`
 The ERP will respond by printing the STATUS HISTORY in a similar format as on the ERP screen display.
- 993 This variable is used to request the ALARM HISTORY of TIE1
 Proper usage is: 993?`<CR>`
 The ERP will respond by printing the ALARM HISTORY in a similar format as on the ERP screen display.
- 994 This variable is used to request the ALARM HISTORY for TIE2
 Proper usage is: 994?`<CR>`
 The ERP will respond by printing the ALARM HISTORY in a similar format as on the ERP screen display.
- 997 This variable may be used to request a printout of the enumerations used for calibration.
 Proper usage is: 997?`<CR>`
- 998 This variable is used to request calibration mode for TIE1 from the serial port.
 Proper usage is as follows: 998,"DESIRED MODE",998,"DESIRED MODE"`<CR>`
- 999 This variable is used to request calibration mode for TIE2 from the serial port.
 Proper usage is as follows: 999,"DESIRED MODE",999,"DESIRED MODE"`<CR>`

BROADCAST MODE

A screen on the Enhanced Remote Panel can be used to output data on a periodic basis. This allows a technician to log data without the need to request each data point independently. This serial transmission is only available on the RS-232 port and will only be in the matched-pair protocol.

There are two groups of data variables. They are called the FAST Access group and the SLOW Access group. Each group may contain 0 to 8 variables for output as entered on the Enhanced Remote Panel screen. A common time base may be entered on the screen to control the serial output rate for each group. The time base for the FAST group is in multiples of seconds and the time base for the SLOW group is in multiples of minutes. This means that if the value of 10 is entered for the FAST group rate, then ALL of the variables in the FAST list will be transmitted every 10 seconds. If a value of 6 is entered for the SLOW group rate then ALL of the variables in the SLOW list will be transmitted every 6 minutes. Each group rate may be independently entered by the technician.

The technician may enter the desired variable numbers into either list using the keyboard of the Enhanced Remote Panel. The variable numbers are listed later in this appendix. A value of 0, (zero) would indicate that no-selection is made.

A common ENABLE / DISABLE is provided to turn the group serial transmission on or off.

The screen is located under VIEW NUMERICAL DATA\ SERIAL DATA from the Main Menu. The screen looks something like the following picture:

SERIAL DATA	
FAST ACCESS	SLOW
ACCESS	
VAR 1: 0	VAR 1: 0
VAR 2: 0	VAR 2: 0
VAR 3: 0	VAR 3: 0
VAR 4: 0	VAR 4: 0
VAR 5: 0	VAR 5: 0
VAR 6: 0	VAR 6: 0
VAR 7: 0	VAR 7: 0
VAR 8: 0	VAR 8: 0
TIME SEC: 0	TIME MIN: 0

MECHANICAL CONNECTIONS

To fasten a laptop or other computer running a standard serial program to the serial port of the ENHANCED REMOTE PANEL you must use following hardware connections.

RS-232 MECHANICAL CONNECTIONS

The connections to the ENHANCED REMOTE PANEL are at the rear of the unit on a standard 9-pin "D" connector labeled J16. Only a 3-wire protocol is supported.

J16 - pin - 3 = Transmit

J16 - pin - 2 = Receive

J16 - pin - 5 = Ground

A null modem cable is required to connect between the Computer's RS232 serial port and the Monitor's Enhanced Remote Panel. The following diagram shows how to construct the RS232 **cable** used to connect with the Enhanced Remote Panel's J16. J16 is a DB9 female connection on the back of the Enhanced Remote Panel.

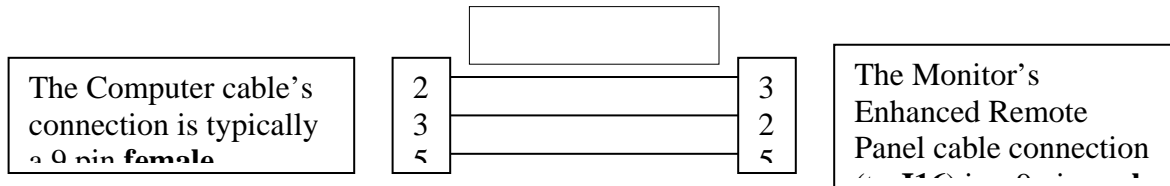

RS-422 MECHANICAL CONNECTIONS

The connections to the ENHANCED REMOTE PANEL are at the rear of the unit on a standard 15-pin "D" connector labeled J17. Only a 4-wire protocol is supported.

J17 - pin - 3 = Receive-A

J17 - pin - 15 = Receive-B

J17 - pin - 2 = Transmit-A

J17 - pin - 14 = Transmit-B

J17 - pin - 1 = Shield Ground

Note that RS-422 communication is also at 9600 baud and it requires using 2 stop bits.

ENHANCED REMOTE MOTHERBOARD JUMPERS for Serial Communication

Jumper	Options	RS-232	RS-422	RS-485
JU3	UART TPU	UART	UART	UART
JU4	UART TPU	UART	UART	UART
JU5	UART TPU 422	UART	422	UART

VARIABLE LIST

The following is a list of variables available from the Enhanced Remote Panel RS232 serial port. TML reserves the right to modify this list at any time. It is best to request a list from the Enhanced Remote Panel with 255? command and the 511? command.

TIE 1 Variables:

1 TIE1_DATE: 5-Sep-2000
2 TIE1_TIME: 4:40:00
3 InstLinVelocity1A: -3.6454
4 AvgLinVelocity1A: -3.8347
5 InstRawVelocity1A: -3.6454
6 AvgRawVelocity1A: -3.8347
7 InstActVolume1A: -22.349
8 AvgActVolume1A: -22.516
9 InstStdVolume1A: -10.047
10 AvgStdVolume1A: -10.122
11 SpanHighVolume1A: 89.9288
12 SpanLowVolume1A: 58.9809
13 ZeroVolume1A: -0.147725
14 primary_status1A: 23
15 extended_status1A: 40
16 NetworkStatus: Network Normal
17 TIE1_MODE: NORMAL
18 SpeedOfSndInst1A: 944.486
19 SpeedOfSndAver1A: 944.423
20 IntMedTempInst1A: -88.5497
21 IntMedTempAver1A: -88.4591
22 ExtMedTempInstTIE1: 713.911
23 ExtMedTempAverTIE1: 713.911
24 ExtMedPressInstTIE1: 29.9285
25 ExtMedPressAverTIE1: 29.9174
26 MIO_StatusTIE1: 0
27 XmitErrorsTIE1: 11
28 TransTimeOutsTIE1: 2103
29 RcvTransFullTIE1: 0
30 LostMsgsTIE1: 0
31 MissedMsgsTIE1: 0
32 ResetCauseTIE1: 1
33 NodeStateTIE1: 4
34 VersionNumberNTWK: 122
35 ErrorLogTIE1: 0
36 SnRatioDnStream1A: 46.8148
37 SnRatioUpStream1A: 53.8
38 PeakRamCntsDnStrm1A: 16928
39 PeakRamCntsUpStrm1A: 16816
40 CalcRamCntsDnStrm1A: 16938.7
41 CalcRamCntsUpStrm1A: 16817
42 PreAmpGainDnStream1A: 150
43 PreAmpGainUpStream1A: 60
44 DigitalGainDnStrm1A: 5
45 DigitalGainUpStrm1A: 5

46 TimeOfFlightDnStrm1A: 0.015472
 47 TimeOfFlightUpStrm1A: 0.015413
 48 SpanHighOffSetTD1A: 19050
 49 SpanLowOffSetTD1A: 18708
 50 R_Factor1A: 0.000231
 51 DnStrmNoiseThLevel1A: 0
 52 UpStrmNoiseThLevel1A: 0
 53 MIO_Ch_1: NO SELECTION
 54 MIO_Ch_1 With Calib: NO
 55 Path_Sel: TIE1 PATH A
 56 MIO_Ch_1 Zero Scale: 0
 57 MIO_Ch_1 Full Scale: 0
 58 MIO_Ch_2: NO SELECTION
 59 MIO_Ch_2 With Calib: NO
 60 Path_Sel: TIE1 PATH A
 61 MIO_Ch_2 Zero Scale: 0
 62 MIO_Ch_2 Full Scale: 0
 63 MIO_Ch_3: NO SELECTION
 64 MIO_Ch_3 With Calib: NO
 65 Path_Sel: TIE1 PATH A
 66 MIO_Ch_3 Zero Scale: 0
 67 MIO_Ch_3 Full Scale: 0
 68 MIO_Ch_4: NO SELECTION
 69 MIO_Ch_4 With Calib: NO
 70 Path_Sel: TIE1 PATH A
 71 MIO_Ch_4 Zero Scale: 0
 72 MIO_Ch_4 Full Scale: 0
 73 Dig_Out_1: NO SELECTION
 74 Dig_Out_2: NO SELECTION
 75 Dig_Out_3: NO SELECTION
 76 Dig_Out_4: NO SELECTION
 77 Dig_Out_5: NO SELECTION
 78 Dig_Out_6: NO SELECTION
 79 Dig_Out_7: NO SELECTION
 80 Dig_Out_8: NO SELECTION
 81 Panel332Version: 1.11
 82 PanelNeuVersion: 1.53
 83 TIE1332Version: 1.11
 84 TIE1NeuVersion: 1.53
 85 MIOVersion: 1.53
 86 TIE1FPGAVersion: 5.20
 87 DnStrmNozzleLength1A: 0.707
 88 UpStrmNozzleLength1A: 0.707
 89 TranToTranDistance1A: 16
 90 OffSet1A: 8
 91 CrossSectAreaTIE1: 100
 92 GeometryUnitsTIE1: FT
 93 MeasurementPathsTIE1: PATH_A
 94 TransducerTypeTIE1: LR003
 95 ToneBurstsTIE1: BURST_1
 96 FlowUnitsTIE1: Kx/M
 97 IPeriodSecsTIE1: 2
 98 IPeriodAverTIE1: 4
 99 AcquireModeAverTIE1: STEP
 100 MinTemperatureTIE1: 20
 101 MaxTemperatureTIE1: 120

ULTRAFLOW 150 GAS FLOW AND TEMPERATURE MONITOR

102 MinFlowVelocityTIE1: 0
103 MaxFlowVelocityTIE1: 100
104 SpanHighSetPointTIE1: 90
105 SpanLowSetPointTIE1: 60
106 ZeroSetPointTIE1: 0
107 CalibToleranceTIE1: 6
108 HourOfAutoCalTIE1: 25
109 MinuteOfAutoCalTIE1: 0
110 CallIntervalHourTIE1: 25
111 IPSpanHighTIE1: 8
112 IPSpanLowTIE1: 0
113 IPAutoZeroTIE1: 8
114 FlowCorrSource1A: POLYNOMIAL
115 LUT_Val_1A_X1: 1
116 LUT_Val_1A_Y1: 1
117 LUT_Val_1A_X2: 2
118 LUT_Val_1A_Y2: 2
119 LUT_Val_1A_X3: 3
120 LUT_Val_1A_Y3: 3
121 Polynomial_1A_A0: 0
122 Polynomial_1A_A1: 1
123 Polynomial_1A_A2: 0
124 Polynomial_1A_A3: 0
125 Polynomial_1A_A4: 0
126 Polynomial_1A_A5: 0
127 TemperatureR1_1A: 0.000231
128 TemperatureCS1_1A: 1000
129 TemperatureR2_1A: 0.000231
130 TemperatureCS2_1A: 1100
131 TemperatureR3_1A: 0.000231
132 TemperatureCS3_1A: 1200
133 StdPressureCorrTIE1: ENABLE
134 RefPressureTIE1: 29.92
135 PressureAtPoint1TIE1: 0
136 A/DCntsAtPoint1TIE1: 819
137 PressureAtPoint2TIE1: 29.54
138 A/DCntsAtPoint2TIE1: 3480
139 StdTempSourceTIE1: EXT
140 StdTempCorrTIE1: ENABLE
141 TempAtPoint1TIE1: 68
142 A/DCntsAtPoint1TIE1: 32
143 TempAtPoint2TIE1: 429
144 A/DCntsAtPoint2TIE1: 500
145 ReferenceTempTIE1: 2945
146 FlowAlarmSelectTIE1: STDVOL_A
147 FlowAlarmModeTIE1: LESSER
148 InstFlowThreshTIE1: -50
149 AverFlowThreshTIE1: -50
150 TempAlarmSelectTIE1: INTTEMP_A
151 TempAlarmModeTIE1: GREATER
152 InstTempThreshTIE1: 201
153 AverTempThreshTIE1: 200
154 TimeBetTransCntsTIE1: 64
155 TimeBetTransSecsTIE1: 0.03328
156 SecsPerRamCountTIE1: 5E-07
157 SecondsPerTDTIE1: 5E-07

158 MinAnalogGainTIE1: 67
 159 MaxAnalogGainTIE1: 4095
 160 MinDigitalGainTIE1: 4
 161 MaxDigitalGainTIE1: 255
 162 AutoGainControlTIE1: DISABLE
 163 PreAmpGainDn1A: 150
 164 PreAmpGainUp1A: 60
 165 DigitalGainDn1A: 5
 166 DigitalGainUp1A: 5
 167 TD_DnStream1A: 18000
 168 TD_UpStream1A: 18000
 169 InDelay1A: 0.00075
 170 NozzleDnStream1A: 0.0006264
 171 NozzleUpStream1A: 0.0006264
 172 NoiseThresholdTIE1
 173 NoiseThDnStream1A: 1
 174 NoiseThUpStream1A: 1
 175 SnNoiseRDnStream1A: 5
 176 SnNoiseRUpStream1A: 5

TIE 1 Path B Variables:

177 InstLinVelocity1B: 0
 178 AvgLinVelocity1B: 0
 179 InstRawVelocity1B: 0
 180 AvgRawVelocity1B: 0
 181 InstActVolume1B: 0
 182 AvgActVolume1B: 0
 183 InstStdVolume1B: 0
 184 AvgStdVolume1B: 0
 185 SpanHighVolume1B: -5.26802E+15
 186 SpanLowVolume1B: -1.66204E+13
 187 ZeroVolume1B: -0.0438843
 188 primary_status1B: 0
 189 extended_status1B: 0
 190 SpeedOfSndInst1B: 0
 191 SpeedOfSndAver1B: 0
 192 IntMedTempInst1B: 0
 193 IntMedTempAver1B: 0
 194 SnRatioDnStream1B: 0
 195 SnRatioUpStream1B: 0
 196 PeakRamCntsDnStrm1B: 0
 197 PeakRamCntsUpStrm1B: 0
 198 CalcRamCntsDnStrm1B: 0
 199 CalcRamCntsUpStrm1B: 0
 200 PreAmpGainDnStream1B: 0
 201 PreAmpGainUpStream1B: 0
 202 DigitalGainDnStrm1B: 0
 203 DigitalGainUpStrm1B: 0
 204 TimeOfFlightDnStrm1B: -0.0009678
 205 TimeOfFlightUpStrm1B: -0.0009678
 206 SpanHighOffSetTD1B: 1003.4
 207 SpanLowOffSetTD1B: 1002.3
 208 R_Factor1B: 0.000231
 209 DnStrmNoiseThLevel1B: 0
 210 UpStrmNoiseThLevel1B: 0

ULTRAFLOW 150 GAS FLOW AND TEMPERATURE MONITOR

211 DnStrmNozzleLength1B: 0.707
212 UpStrmNozzleLength1B: 0.707
213 TranToTranDistance1B: 10.625
214 OffSet1B: 8
215 FlowCorrSource1B: POLYNOMIAL
216 LUT_Val_1B_X1: 1
217 LUT_Val_1B_Y1: 1
218 LUT_Val_1B_X2: 2
219 LUT_Val_1B_Y2: 2
220 LUT_Val_1B_X3: 3
221 LUT_Val_1B_Y3: 3
222 Polynomial_1B_A0: 0
223 Polynomial_1B_A1: 1
224 Polynomial_1B_A2: 0
225 Polynomial_1B_A3: 0
226 Polynomial_1B_A4: 0
227 Polynomial_1B_A5: 0
228 TemperatureR1_1B: 0.000231
229 TemperatureCS1_1B: 1000
230 TemperatureR21B: 0.000231
231 TemperatureCS2_1B: 1100
232 TemperatureR3_1B: 0.000231
233 TemperatureCS3_1B: 1200
234 PreAmpGainDn1B: 70
235 PreAmpGainUp1B: 70
236 DigitalGainDn1B: 5
237 DigitalGainUp1B: 5
238 TD_DnStream1B: 1000
239 TD_UpStream1B: 1000
240 InDelay1B: 0.000215
241 NozzleDnStream1B: 0.0006264
242 NozzleUpStream1B: 0.0006264
243 NoiseThDnStream1B: 1
244 NoiseThUpStream1B: 1
245 SnNoiseRDnStream1B: 5
246 SnNoiseRUpStream1B: 5

TIE 1 Combined Path AB Variables:

247 InstLinVelocity1AB: 0
248 InstRawVelocity1AB: 0
249 InstActVolume1AB: 0
250 InstStdVolume1AB: 0
251 SpanHighVolume1AB: 4.12342E-07
252 SpanLowVolume1AB: 0
253 ZeroVolume1AB: 0.997581
254 NumberOfTIEBoxes: TIE1 & TIE2
INVALID VARIABLE NUMBER: 255

TIE 2 Variables:

256 TIE2_DATE: 5-Sep-2000
257 TIE2_TIME: 4:42:38
258 InstLinVelocity2A: -2.7184
259 AvgLinVelocity2A: -2.6185
260 InstRawVelocity2A: -2.7184
261 AvgRawVelocity2A: -2.5927
262 InstActVolume2A: -17.229
263 AvgActVolume2A: -15.556
264 InstStdVolume2A: -7.7445
265 AvgStdVolume2A: -6.9926
266 SpanHighVolume2A: 0
267 SpanLowVolume2A: 0
268 ZeroVolume2A: 0
269 primary_status2A: 23
270 extended_status2A: 40
271 NetworkStatus: Network Normal
272 TIE2_MODE: NORMAL
273 SpeedOfSndInstTIE2A: 945.231
274 SpeedOfSndAverTIE2A: 945.399
275 IntMedTempInstTIE2A: -88.1869
276 IntMedTempAverTIE2A: -88.0546
277 ExtMedTempInstTIE2: 713.911
278 ExtMedTempAverTIE2: 713.911
279 ExtMedPressInstTIE2: 29.9174
280 ExtMedPressAverTIE2: 29.9119
281 MIO_StatusTIE2: 0
282 XmitErrorsTIE2: 11
283 TransTimeOutsTIE2: 2103
284 RcvTransFullTIE2: 0
285 LostMsgsTIE2: 0
286 MissedMsgsTIE2: 0
287 ResetCauseTIE2: 1
288 NodeStateTIE2: 4
289 VersionNumberNTWK: 122
290 ErrorLogTIE2: 1
291 SnRatioDnStream2A: 76.5926
292 SnRatioUpStream2A: 74.6818
293 PeakRamCntsDnStrm2A: 16875
294 PeakRamCntsUpStrm2A: 16801
295 CalcRamCntsDnStrm2A: 16902.9
296 CalcRamCntsUpStrm2A: 16820.1
297 PreAmpGainDnStream2A: 150
298 PreAmpGainUpStream2A: 60
299 DigitalGainDnStrm2A: 5
300 DigitalGainUpStrm2A: 5
301 TimeOfFlightDnStrm2A: 0.015463
302 TimeOfFlightUpStrm2A: 0.01541
303 SpanHighOffSetTD2A: 19049
304 SpanLowOffSetTD2A: 18707
305 R_Factor2A: 0.000231
306 DnStrmNoiseThLevel2A: 0
307 UpStrmNoiseThLevel2A: 0
308 Panel332Version: 1.07
309 PanelNeuVersion: 1.53

ULTRAFLOW 150 GAS FLOW AND TEMPERATURE MONITOR

310 TIE2332Version: 1.11
311 TIE2NeuVersion: 1.53
312 MIOVersion: 1.53
313 TIE2FPGAVersion: 5.20
314 DnStrmNozzleLength2A: 0.707
315 UpStrmNozzleLength2A: 0.707
316 TranToTranDistance2A: 16
317 OffSet2A: 8
318 CrossSectAreaTIE2: 100
319 GeometryUnitsTIE2: FT
320 MeasurementPathsTIE2: PATH_A
321 TransducerTypeTIE2: LR003
322 ToneBurstsTIE2: BURST_1
323 FlowUnitsTIE2: Kx/M
324 IPeriodSecsTIE2: 2
325 IPeriodAverTIE2: 4
326 AcquireModeAverTIE2: STEP
327 MinTemperatureTIE2: 20
328 MaxTemperatureTIE2: 120
329 MinFlowVelocityTIE2: 0
330 MaxFlowVelocityTIE2: 100
331 SpanHighSetPointTIE2: 90
332 SpanLowSetPointTIE2: 60
333 ZeroSetPointTIE2: 0
334 CalibToleranceTIE2: 6
335 HourOfAutoCalTIE2: 25
336 MinuteOfAutoCalTIE2: 0
337 CallIntervalHourTIE2: 25
338 IPSpanHighTIE2: 8
339 IPSpanLowTIE2: 0
340 IPAutoZeroTIE2: 8
341 FlowCorrSource2A: POLYNOMIAL
342 LUT_Val_2A_X1: 1
343 LUT_Val_2A_Y1: 1
344 LUT_Val_2A_X2: 2
345 LUT_Val_2A_Y2: 2
346 LUT_Val_2A_X3: 3
347 LUT_Val_2A_Y3: 3
348 Polynomial_2A_A0: 0
349 Polynomial_2A_A1: 1
350 Polynomial_2A_A2: 0
351 Polynomial_2A_A3: 0
352 Polynomial_2A_A4: 0
353 Polynomial_2A_A5: 0
354 TemperatureR1_2A: 0.000231
355 TemperatureCS1_2A: 1000
356 TemperatureR2_2A: 0.000231
357 TemperatureCS2_2A: 1100
358 TemperatureR3_2A: 0.000231
359 TemperatureCS3_2A: 1200
360 StdPressureCorrTIE2: ENABLE
361 RefPressureTIE2: 29.92
362 PressureAtPoint1TIE2: 0
363 A/DCntsAtPoint1TIE2: 819
364 PressureAtPoint2TIE2: 29.54
365 A/DCntsAtPoint2TIE2: 3480

366 StdTempSourceTIE2: EXT
 367 StdTempCorrTIE2: ENABLE
 368 TempAtPoint1TIE2: 68
 369 A/DCntsAtPoint1TIE2: 32
 370 TempAtPoint2TIE2: 429
 371 A/DCntsAtPoint2TIE2: 500
 372 ReferenceTempTIE2: 2945
 373 FlowAlarmSelectTIE2: STDVOL_A
 374 FlowAlarmModeTIE2: LESSER
 375 InstFlowThreshTIE2: -50
 376 AverFlowThreshTIE2: -50
 377 TempAlarmSelectTIE2: INTTEMP_A
 378 TempAlarmModeTIE2: GREATER
 379 InstTempThreshTIE2: 201
 380 AverTempThreshTIE2: 200
 381 TimeBetTransCntsTIE2: 64
 382 TimeBetTransSecsTIE2: 0.03328
 383 SecsPerRamCountTIE2: 5E-07
 384 SecondsPerTDTIE2: 5E-07
 385 MinAnalogGainTIE2: 67
 386 MaxAnalogGainTIE2: 4095
 387 MinDigitalGainTIE2: 4
 388 MaxDigitalGainTIE2: 255
 389 AutoGainControlTIE2: DISABLE
 390 PreAmpGainDn2A: 150
 391 PreAmpGainUp2A: 60
 392 DigitalGainDn2A: 5
 393 DigitalGainUp2A: 5
 394 TD_DnStream2A: 18000
 395 TD_UpStream2A: 18000
 396 InDelay2A: 0.00075
 397 NozzleDnStream2A: 0.0006264
 398 NozzleUpStream2A: 0.0006264
 399 NoiseThreshold2A: ENABLE
 400 NoiseThDnStream2A: 1
 401 NoiseThUpStream2A: 1
 402 SnNoiseRDnStream2A: 5
 403 SnNoiseRUpStream2A: 5

TIE 2 Path B Variables:

404 InstLinVelocity2B: 0
 405 AvgLinVelocity2B: 0
 406 InstRawVelocity2B: 0
 407 AvgRawVelocity2B: 0
 408 InstActVolume2B: 0
 409 AvgActVolume2B: 0
 410 InstStdVolume2B: 0
 411 AvgStdVolume2B: 0
 412 SpanHighVolume2B: 0
 413 SpanLowVolume2B: 0
 414 ZeroVolume2B: 0
 415 primary_status2B: 0
 416 extended_status2B: 0
 417 SpeedOfSndInst2B: 0
 418 SpeedOfSndAver2B: 0

ULTRAFLOW 150 GAS FLOW AND TEMPERATURE MONITOR

419 IntMedTempInst2B: 0
420 IntMedTempAver2B: 0
421 SnRatioDnStream2B: 0
422 SnRatioUpStream2B: 0
423 PeakRamCntsDnStrm2B: 0
424 PeakRamCntsUpStrm2B: 0
425 CalcRamCntsDnStrm2B: 0
426 CalcRamCntsUpStrm2B: 0
427 PreAmpGainDnStream2B: 0
428 PreAmpGainUpStream2B: 0
429 DigitalGainDnStrm2B: 0
430 DigitalGainUpStrm2B: 0
431 TimeOfFlightDnStrm2B: -0.0009678
432 TimeOfFlightUpStrm2B: -0.0009678
433 SpanHighOffSetTD2B: 1003.4
434 SpanLowOffSetTD2B: 1002.3
435 R_Factor2B: 0.000231
436 DnStrmNoiseThLevel2B: 0
437 UpStrmNoiseThLevel2B: 0
438 DnStrmNozzleLength2B: 0.707
439 UpStrmNozzleLength2B: 0.707
440 TranToTranDistance2B: 10.625
441 OffSet2B: 8
442 FlowCorrSource2B: POLYNOMIAL
443 LUT_Val_2B_X1: 1
444 LUT_Val_2B_Y1: 1
445 LUT_Val_2B_X2: 2
446 LUT_Val_2B_Y2: 2
447 LUT_Val_2B_X3: 3
448 LUT_Val_2B_Y3: 3
449 Polynomial_2B_A0: 0
450 Polynomial_2B_A1: 1
451 Polynomial_2B_A2: 0
452 Polynomial_2B_A3: 0
453 Polynomial_2B_A4: 0
454 Polynomial_2B_A5: 0
455 TemperatureR1_2B: 0.000231
456 TemperatureCS1_2B: 1000
457 TemperatureR2_2B: 0.000231
458 TemperatureCS2_2B: 1100
459 TemperatureR3_2B: 0.000231
460 TemperatureCS3_2B: 1200
461 PreAmpGainDn2B: 70
462 PreAmpGainUp2B: 70
463 DigitalGainDn2B: 5
464 DigitalGainUp2B: 5
465 TD_DnStream2B: 1000
466 TD_UpStream2B: 1000
467 InDelay2B: 0.000215
468 NozzleDnStream2B: 0.0006264
469 NozzleUpStream2B: 0.0006264
470 NoiseThDnStream2B: 1
471 NoiseThUpStream2B: 1
472 SnNoiseRDnStream2B: 5
473 SnNoiseRUpStream2B: 5

TIE 2 Combined Path AB Variables:

474 InstLinVelocity2AB: 0
475 InstRawVelocity2AB: 0
476 InstActVolume2AB: 0
477 InstStdVolume2AB: 0
478 SpanHighVolume2AB: 0
479 SpanLowVolume2AB: 0
480 ZeroVolume2AB: 0
INVALID VARIABLE NUMBER: 481
INVALID VARIABLE NUMBER: 482
INVALID VARIABLE NUMBER: 483
INVALID VARIABLE NUMBER: 484
INVALID VARIABLE NUMBER: 485
INVALID VARIABLE NUMBER: 486
INVALID VARIABLE NUMBER: 487
INVALID VARIABLE NUMBER: 488
INVALID VARIABLE NUMBER: 489
INVALID VARIABLE NUMBER: 490
INVALID VARIABLE NUMBER: 491
INVALID VARIABLE NUMBER: 492
INVALID VARIABLE NUMBER: 493
INVALID VARIABLE NUMBER: 494
INVALID VARIABLE NUMBER: 495
INVALID VARIABLE NUMBER: 496
INVALID VARIABLE NUMBER: 497
INVALID VARIABLE NUMBER: 498
INVALID VARIABLE NUMBER: 499
INVALID VARIABLE NUMBER: 500
INVALID VARIABLE NUMBER: 501
INVALID VARIABLE NUMBER: 502
INVALID VARIABLE NUMBER: 503
INVALID VARIABLE NUMBER: 504
INVALID VARIABLE NUMBER: 505
INVALID VARIABLE NUMBER: 506
INVALID VARIABLE NUMBER: 507
INVALID VARIABLE NUMBER: 508
INVALID VARIABLE NUMBER: 509
INVALID VARIABLE NUMBER: 510
INVALID VARIABLE NUMBER: 511